

Product Specification Sheet



MGH

JACKSHAFT OPERATOR

STANDARD FEATURES

- **Motor:**
60Hz high starting torque, continuous-duty industrial type, single phase capacitor start or 3 phase motor, open drip proof with enclosed ends or drip cover, protected against overload. Also available with 50Hz 220V 1 phase and 380V 3 phase motor, consult inside sales.
- **Reduction:**
40:1 worm gear in oil bath reducer with air breather and sealed ball bearings. Output shaft is 1-1/4" with 1/4" keyway up to 1-1/2HP, 1-3/8" output shaft with 5/16" keyway above 1-1/2HP. Output shaft is supported by cast iron flanged pillow block bearings. Output shaft speed: 43 rpm.
- **Drive:**
#50 roller chain with a 50B12 sprocket for the operator drive shaft (up to 1-1/2HP), 50B15 sprocket for the drive shaft (above 1-1/2HP). #60 roller chain optional. Door sprocket selected for a door travel of 6"/s to 12"/s.
- **Brake:**
Electrically activated drum-band type solenoid brake. Option: brake motor.
- **Manual Operation:**
Emergency manual chain hoist. Floor level chain hoist engaging device with electrical cut-out. An electrical interlock automatically disconnects power to the motor operator when chain hoist is engaged. Hoist on right is standard, but it can be easily moved to the left in the field.
- **Electrical Enclosure:**
All electrical components are in a Nema 1 enclosure. Simple slide-off cover.
- **Limit System:**
Rotary-type oil-impregnated steel cams, commercial grade switches. Limit shaft is supported by self-lubricating bronze bushings for increased precision. Remains in time when there is a manual operation or after the motor has been removed.
- **Accu-cam® Feature:**
Precise and quick one-handed adjustment of the limits.
- **Corrosion Protection:**
Reducer, control enclosure and frames protected by baked on, long lasting enamel finish.
- **Mounting:**
Right or left wall mounting.
- **Shipping Weight:**
Approx. 137 Lbs - 62 Kg.
- **Warranty:**
2 Years.

Emergency Manual Chain Hoist

With floor level chain hoist engaging device and electrical cut-out

Accu-cam® Limit Feature

For precise and quick one-hand limit setting adjustments

Cast Iron Pillow Block Bearings

Flanged pillow block bearings on the output shaft

Simple Slide-Off Cover

For easy access to components and wiring



The MGH is a very heavy-duty worm gear industrial operator designed for use on industrial standard, high and vertical lift sectional doors or rolling doors and grilles.

The operator can be wall mounted on either side of the door and incorporates a chain hoist for manual operation with a floor level engaging device with electrical cut-out.

The operator is available with the new Electronic Control Board (BOARD 070) with or without the option of electrical control for MONITORED external entrapment protection devices (UL325-2010 compliant).



When you think
Commercial Door OPERATORS,
just think OPERA.

For more information:
www.devancocanada.com
or call toll free at 855-931-3334

CONTROL OPTIONS

• ECB Units (BOARD 070):

24Vdc relaying circuit with a 40VA class II transformer, non-volatile memory. Features available: On-board radio receiver, 1.5s delay on reverse, programmable maximum run timer, mid-stop, timer to close (suspension possible from floor level), independent input loop terminal, advance close system, test buttons, reverse wiring detection and door lock sensor. Operating mode selectable on site: C2, B2, D1, E2, T or TS.

• "M" Version:



Provides the monitoring of Primary External Entrapment Protection Devices. Includes monitored photo cells (PHOTO 062 standard). In this mode, Ancillary Entrapment Protection Devices (optional) may be used to supplement primary entrapment protection, such as non-monitored photo cells, 2-wire non-monitored sensing edges and pneumatic sensing edges. Certifications: CSA C22.2-247.92 and UL325.

• "E" Version:



No monitoring function. Certifications: CSA C22.2-247.92 and compliant to UL325 5th Ed. PRIOR to August 2010 revision.

• Contactor Units:

24VAc control circuit, 40VA class II transformer, fuse protected on output, heavy-duty across-the-line linear reversing contactor with mechanical interlock.

• B2/C2 Units:



C2 wiring is standard. B2 can be set very easily by moving one wire. Available options: delay on reverse, timer to close, double limits, etc... Certifications: CSA C22.2-247.92 and compliant to UL325 5th Ed. PRIOR to August 2010 revision.

Note: CSA C22.2-247.92 and UL325 apply to units intended to be used in ordinary locations in accordance with the Canadian Electrical Code, Part I and the National Electrical Code, NFPA 70, respectively.

MAIN OPTIONS

• Control Accessories:

Terminal strip allows for the connection of 3-button stations (one supplied with the operator), non-monitored sensing edges, non-monitored photo cells, one push-button radio control (external strip), ceiling pull switches, key switches, loop detectors, external interlocks, universal auxiliary output module. 2A fuse protected 24VAc output is available for accessory power supply. NEMA 4/12 or NEMA 4X protected monitored photo cells upgrade available.

• Environmental Modifications:

NEMA 4/12, NEMA 4X and NEMA 7/9 enclosures.

• Friction Clutch (Optional):

Easily adjustable slip clutch, ideally positioned on output shaft. Recommended for sectional doors.

• Mechanical Accessories:

Chain spreader, hand crank, etc...consult inside sales.

• Mechanical Modifications:

Left hand chain hoist, brake motor, #60 roller chain and sprocket on final drive, etc... consult inside sales.

DIMENSIONS

Clearance: Side room required 17" (432 mm)

With friction clutch up to 1-1/2 HP add: 2.375" (60 mm)

With friction clutch above 1-1/2 HP add: 1.875" (48 mm)

With brake motor add: 5.000" (127 mm) to height

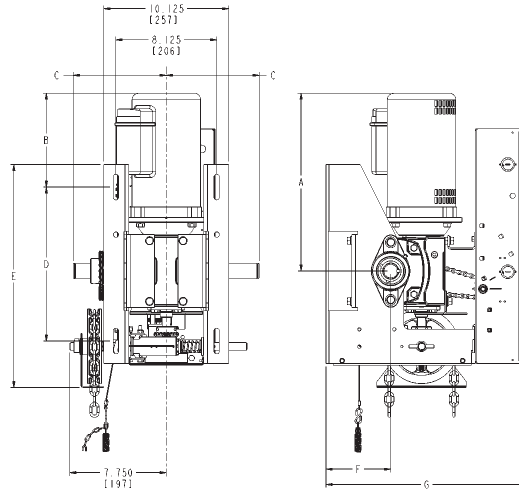

	UP TO 1.5 HP	2 TO 5 HP
A	14.625 MAX. [371]	17.500 MAX. [443]
B	8.000 MAX. [203]	11.250 MAX. [286]
C	7.500 [191]	8.000 [203]
D	12.375 [314]	12.625 [321]
E	18.000 [457]	17.875 [454]
F	9.250 [235]	5.875 [149]
G	16.250 [413]	17.625 [448]

MOTOR SELECTION

Maximum Size of Door in Square Feet

Horse Power	Rolling Doors					Sectional Doors				General Guideline
	Insulated Steel	16 ga. Steel	Steel Grilles 20 ga. Steel	Alu. Door 22 ga. Steel	Alu. Grilles 24 ga. Steel	Steel 18 ga. ins.	Steel 18 ga. 20 ga. ins.	Wood Steel 20 ga. 22 & 24 ga. ins.	Aluminum Steel 22 & 24 ga.	
1/2	157	236	260	319	358	196	245	314	343	392
3/4	206	294	358	451	515	270	319	441	490	549
1	255	358	446	574	613	294	392	490	564	613
1-1/2	353	486	633	625	-	373	466	549	613	-
2	451	613	660	-	-	560	620	660	-	-
3	620	830	890	-	-	830	870	910	-	-
5	*	*	*	-	-	*	*	*	-	-

* Consult inside sales

OPERATOR RANGE

Current Consumption (Amp.)

Horse Power	120V 1 Ph	240V 1 Ph	208/240V 3 Ph	480V 3 Ph	600V 3 Ph	General Guideline
1/2	9.0	4.5	2.2	1.1	-	
3/4	11.2	5.6	3.2	1.5	1.2	
1	13.6	6.8	3.7	1.7	1.4	
1-1/2	19.6	9.8	5.3	2.5	2.0	
2	-	-	6.5	3.1	2.5	
3	-	-	8.5	4.1	3.3	
5	-	-	16.7	7.6	6.1	

