

PRO-LT

COMMERCIAL LIMITED DUTY BELT DRIVE TROLLEY OPERATOR

Designed for use on commercial doors with standard lift tracks that require no more than 15 cycles per hour

STANDARD FEATURES

- 2 year Warranty
- 24V class 2 control circuit with 40VA transformer to protect against short circuit
- External radio control terminal strip
- Low friction powder metal limit cam nuts with fully adjustable rotary type limit switch assembly
- Three button open-close-stop control station Nema-1
- 1/2 HP high starting torque, instant reversible motor protected by internal automatic thermal overload device
- Motor removable without affecting limit settings
- Heavy duty 4L V-belt
- #41 roller chain & sprockets on all internal drives
- Adjustable friction clutch
- 3/4" permanently lubricated & sealed ball bearings on pulley shaft
- 1" permanently lubricated & sealed ball bearings on final drive shaft
- Solenoid brake available (optional PRO-LTB)
- Emergency quick release disconnect for manual operation
- #410 roller chain drive on trolley rail assembly
- Trolley track for doors up to 12' standard
- Door speed 9" per second
- Baked on dark grey coat finish
- Shipping weight 60 lbs (excludes rails)
- For use on doors up to 16' high
- N-1 Micanan photocells included for doors up to 24' wide



When ordering a PRO-LT operator, supply the following information:

- Door height
- Door width
- Voltage/ Phase
- Safety devices
- Control circuit options (see page 5-6)

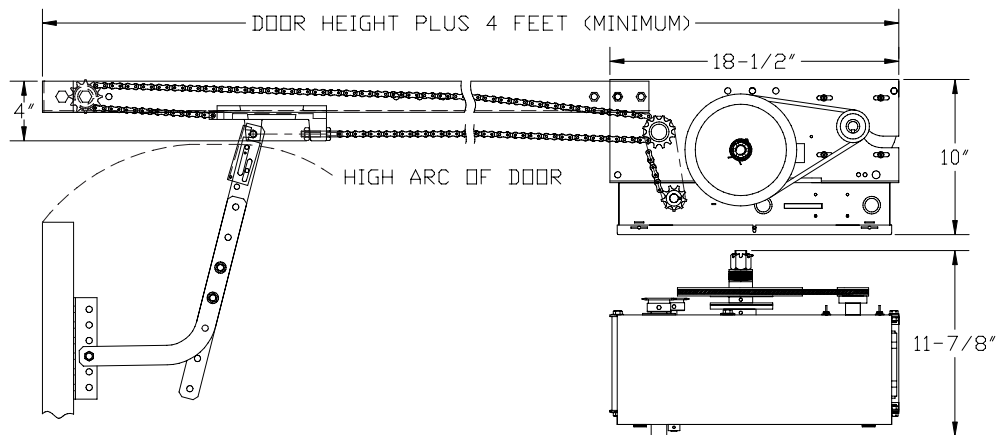

For more information, please visit www.devancocanada.com or call toll free at 855-931-3334