

SFSD EXTENSION BRACKETS

INSTALLATION INSTRUCTIONS

IMPORTANT: Refer to the SFSD reference manual DT0054 for additional instructions and important information. These brackets should be used only with Canimex Torque Force SFSD device.

217483 INSTALLATION ON WALL

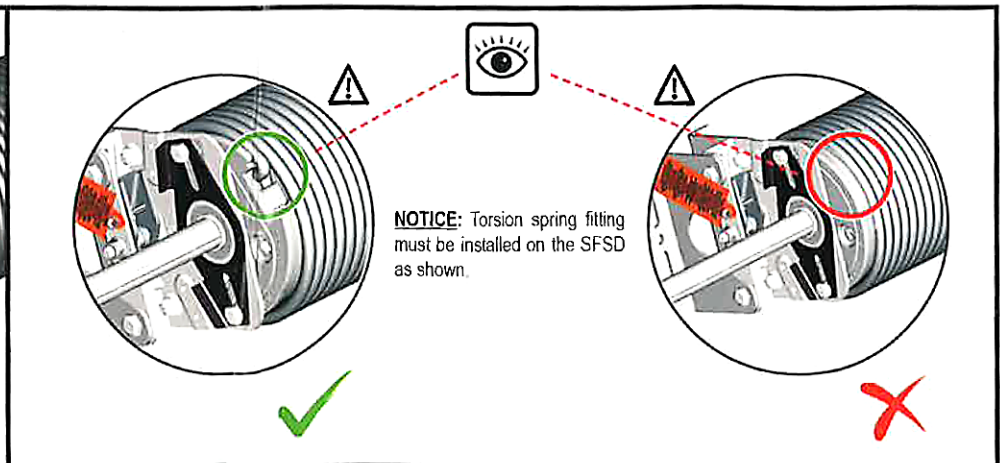
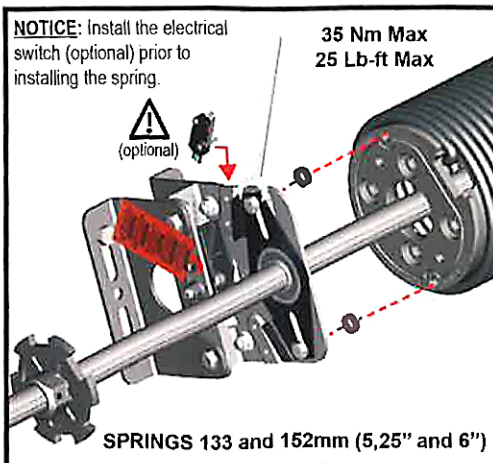
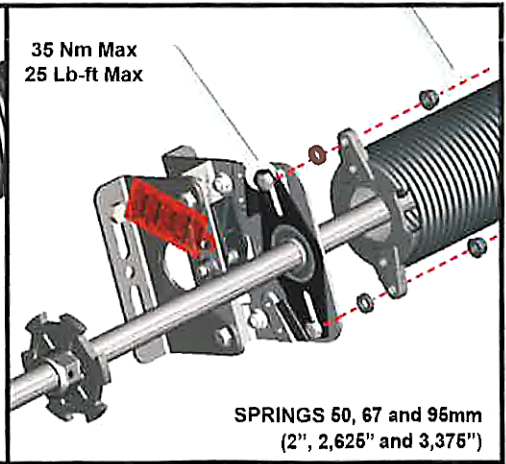
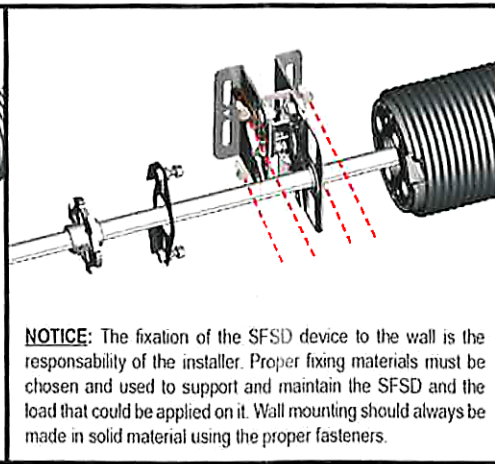
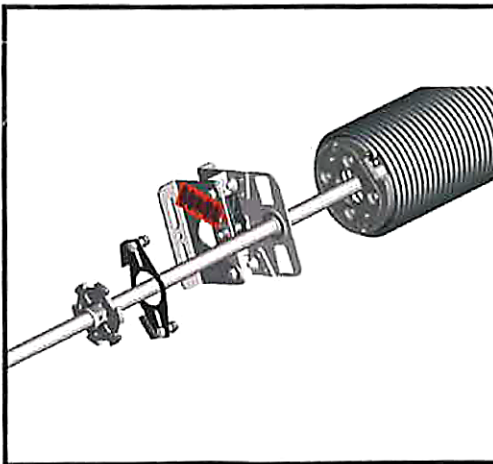
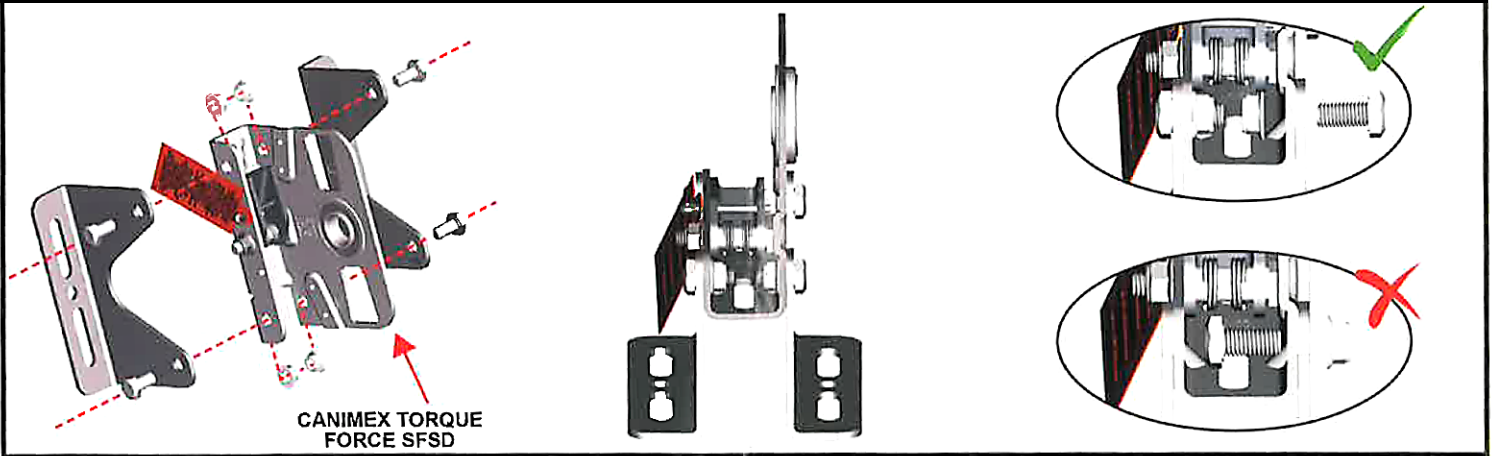

SFSD EXTENSION BRACKETS

INSTALLATION INSTRUCTIONS

217483 INSTALLATION "LOW BEAM CONCEPT"

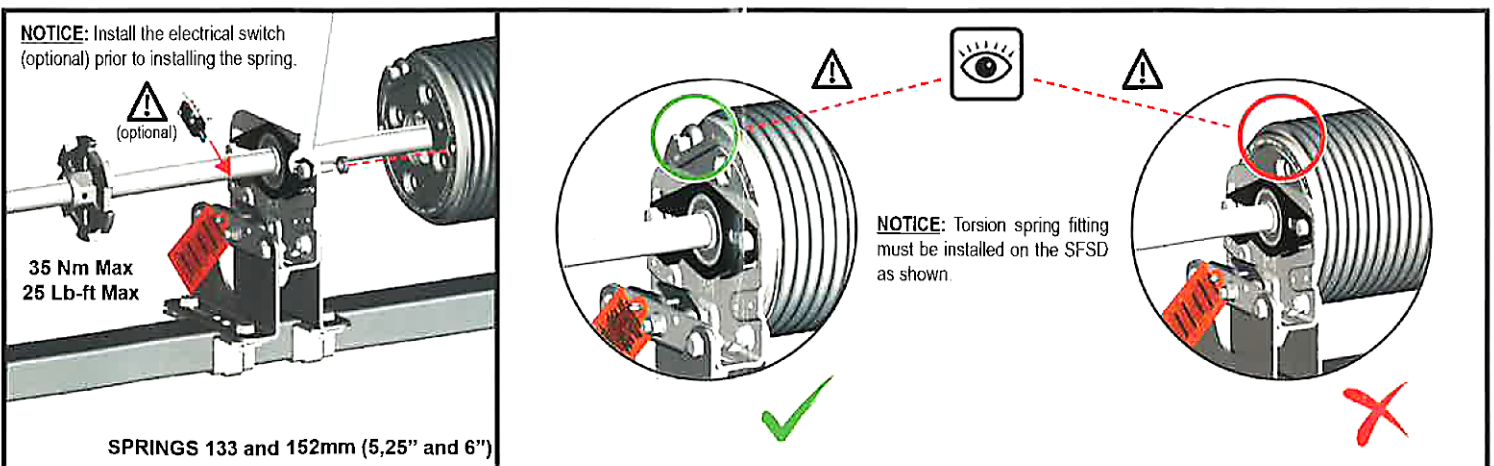
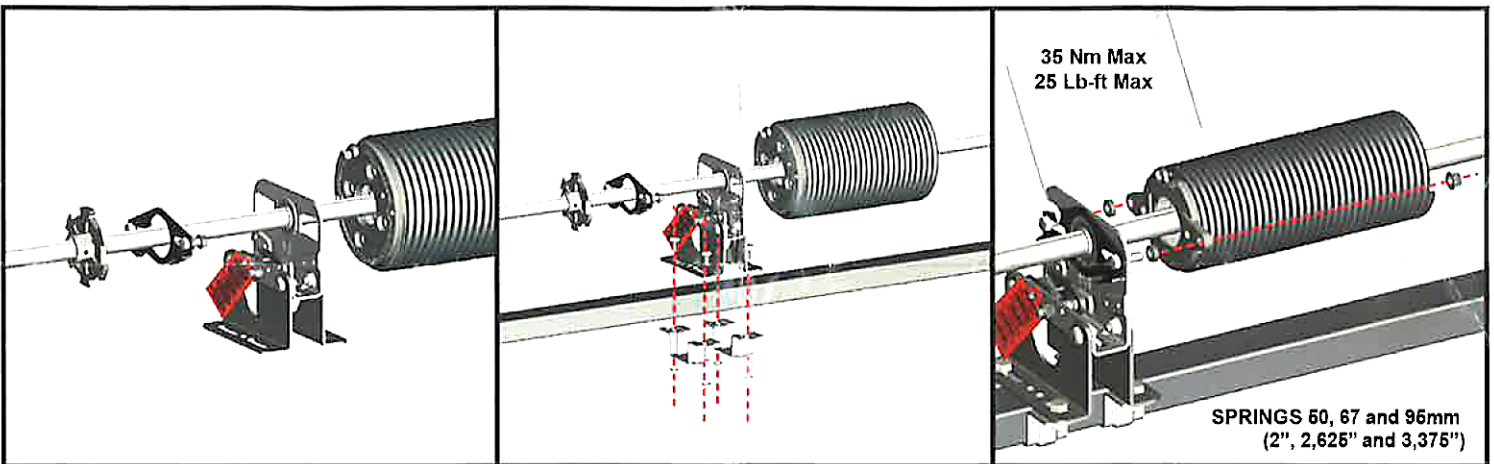
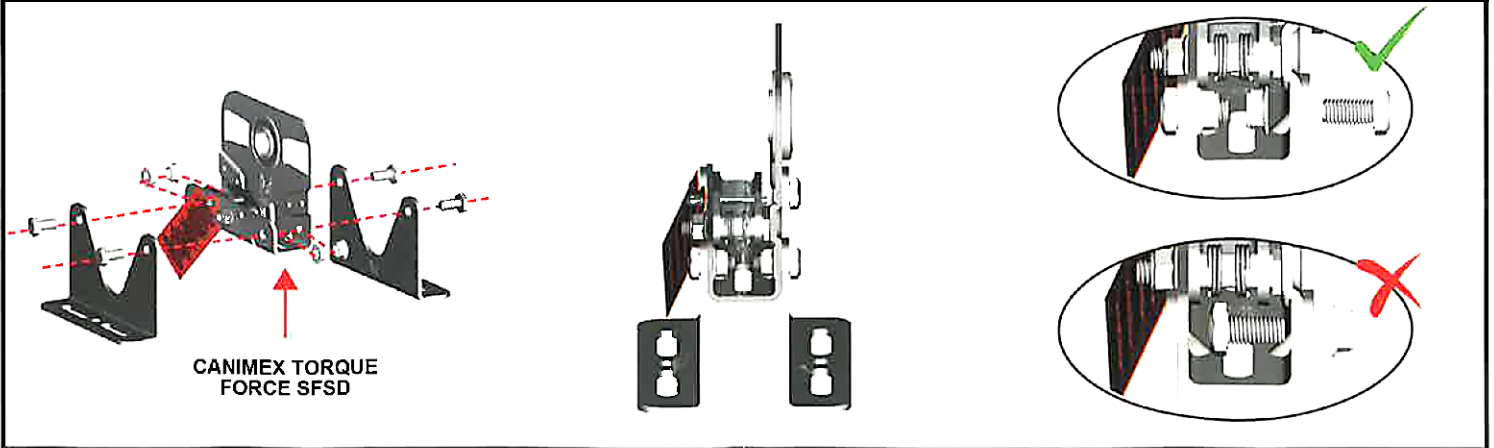

For more information, please visit www.devancocanada.com or call toll free at 855-931-3334