

INSTALLATION

Mounting the **standby power unit (SPU)** can be done using one of two methods. The SPU can be mounted directly on top of the motor unit or it can be secured on a structural support just above it.

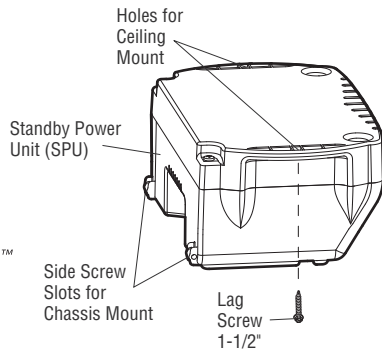

1. Mounting the SPU Directly to the Motor Unit.

- Position the SPU on top of the motor unit. Make sure the motor unit power cord is drawn out from beneath the SPU. The SPU should sit firmly on top of the motor unit. Adjust angle iron placement so that it is out of the way of the SPU's installation (Figure 1).
- Align the two screw slots on the SPU to the back chassis holes.
- Secure the SPU to each side of the chassis flanges with 3/4" screws provided.

2. Mounting the SPU Directly to a Structural Support.

- After the motor unit has been installed, the SPU can be mounted to either the ceiling or a wall within 3' (.9 m) of the motor unit.
- Position the SPU as desired to a structural support (ceiling joist or wall stud) (Figure 2).
- Attach the SPU to the support using the mounting holes on either side of the SPU.
- Secure the SPU using the 1-1/2" lag screws (provided).

3. Connect the SPU to the Motor Unit.

- Disconnect the motor unit from the electrical outlet.
- Connect the SPU cord into the connector on the end panel on the motor unit. Connect the motor unit to the electrical outlet. The SPU will activate and all LEDs will turn on for 3 seconds.
- The green LED will begin flashing, indicating the SPU is charging from the motor unit.

IMPORTANT NOTE: Installation of SPU when permanent electrical power is not available (such as new construction and the electricity is not installed) may damage the batteries. Unplug SPU after testing to prevent damage.

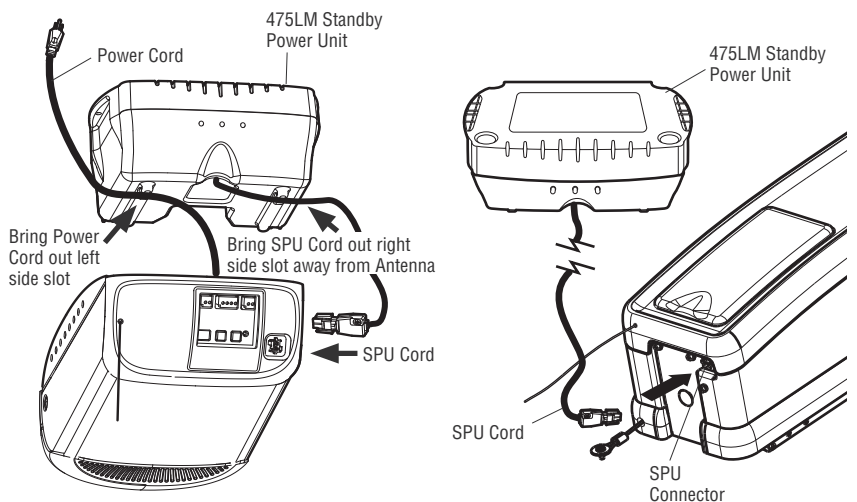

⚠ WARNING

To prevent possible **SERIOUS INJURY** or **DEATH** from electrocution, disconnect **ALL** electric and battery power **BEFORE** performing **ANY** service or maintenance.

CAUTION

ALWAYS wear protective gloves and eye protection when changing the battery or working around the battery compartment.

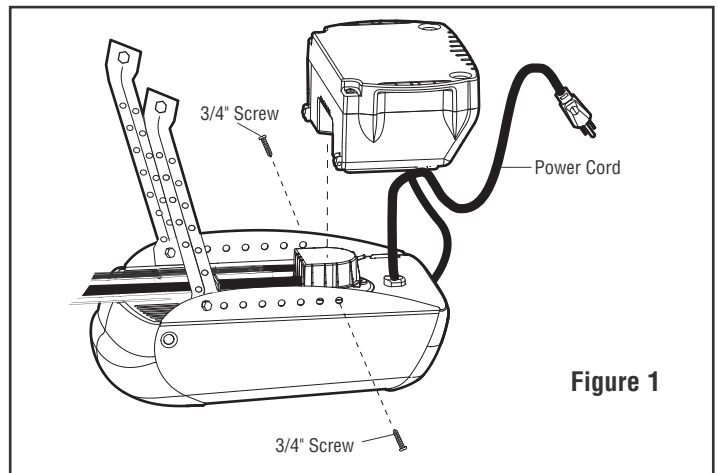

Figure 1

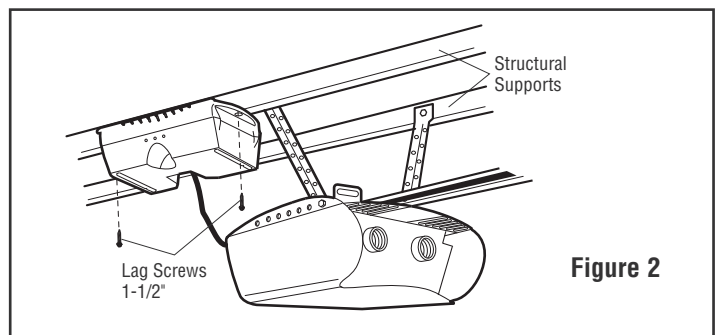

Figure 2

CAUTION

To reduce the risk of FIRE or INJURY to persons use only Chamberlain part #41B591 for replacement batteries.

OPERATION

1. Test the installed SPU with the motor unit.

To test the SPU, disconnect the motor unit power cord from the electrical outlet.

- A solid yellow LED indicates the SPU is operating on battery power.
- A flashing yellow LED with beep indicates the SPU is operating on battery power and that the battery charge is low.
- To test whether the SPU is functioning properly, open and close the garage door.
- Re-connect the motor unit power cord back into the electrical outlet.
- Verify that the green LED is flashing on the SPU (indicates that the SPU is now charging).
- Test completed.

2. Charge the battery.

- Allow the batteries 24 to 48 hours to fully charge before using the SPU system.

A fully charged SPU supplies 24 Vdc to the motor unit for one to two days of normal operation during an electrical power outage. If the battery voltage drops too low, the batteries will disconnect and the motor unit will no longer operate under battery power.

After the electrical power has been restored, the batteries will recharge within 48 hours. Under normal usage batteries will last 3 to 5 years.

To obtain maximum battery life and prevent damage, also disconnect the standby power if you unplug the motor unit while on vacation or any other extended period of time.

NOTE: Door operation may be limited until batteries are fully charged. The motor unit's lights will not turn on during SPU mode.

STANDBY POWER UNIT (SPU) DIAGNOSTICS

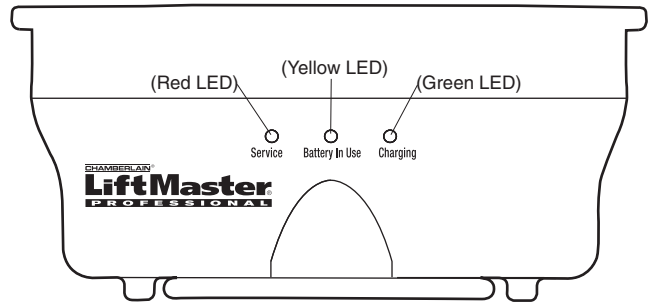

GREEN LED:

All systems are normal.

- A solid LED light indicates the batteries are fully charged.
- A flashing LED indicates the batteries are being charged.

NOTE: Batteries do not have to be fully charged to operate the motor unit.

YELLOW LED:

The motor unit has lost power and is operating off of the SPU.

- A solid LED with beep, sounding approximately every 2 seconds, indicates the motor unit is activating the door and is operating off of the SPU.
- A flashing LED with beep, sounding every 30 seconds, indicates batteries are low.
- Once the power is restored, the SPU will recharge. This is indicated by a flashing green LED.

RED LED:

An error has been detected and the SPU will automatically shut off. The SPU will attempt to restart by reconnecting to the batteries. If the error is still present it will shut itself off again. This process will repeat every 5 minutes or until the error has been resolved. This is used to prevent further draining of the batteries.

- If a red LED remains on when the power is restored, and is accompanied by a beep sounding every 30 seconds, please call for service.

Replacement Parts

12V Rechargeable Batteries (2)	41B591
Power Supply Board	41A5726
Fuse	72A35

***HOW TO ORDER
REPAIR PARTS***

DEVANCO CANADA

19192 HAY ROAD, UNIT Q
SUMMERSTOWN, ON K0C 2E0

TOLL FREE: 855-931-3334

www.devancocanada.com

**WHEN ORDERING REPAIR PARTS
PLEASE SUPPLY THE
FOLLOWING INFORMATION:**

- ✓ PART NUMBER**
- ✓ DESCRIPTION**
- ✓ MODEL NUMBER**