

# AUTO RECONNECT TROLLEY KIT (ARK)

**Models MT and T  
(1/3 & 1/2HP only)**

 **WARNING**

To prevent possible **SERIOUS INJURY** or **DEATH**, disconnect electric power to operator **BEFORE** installing.  
**ALL** installations and electrical connections **MUST** be made by a qualified individual.

Instructions to install Auto Reconnect Trolley Kit (ARK). Spring loaded trolley features nylon inserts for quiet operation. Auto reconnect feature eliminates the need to manually re-attach the door arm to the trolley after emergency disconnect.

**BEFORE INSTALLATION**

- Refer to disassembly instructions below for all existing installations.
- Refer to owner's manual provided with operator for all mounting and wiring instructions.
- Refer to backside for pre-assembly instructions of auto reconnect trolley kit.
- Disconnect power to operator.

**EXISTING INSTALLATIONS**

If this kit is being installed on a existing trolley operator, you will be required to disassemble track and operator assembly to allow removal of the front idler and the trolley slider.

**Ensure you have adequate support of the operator as you disassemble. It may be necessary to completely detach operator from the overhead supports and reassemble trolley reconnect kit at floor level.**

1. Disconnect trolley straight arm from door curved arm.
2. Locate master links at either end of trolley slider and disconnect drive chain.
3. Remove front idler assembly at the head of the track. Remove trolley slider.

**PACKING LIST**

PART #	DESCRIPTION	QTY
10-10203	Curved arm	1
10-10204	Door bracket	1
10-10205	Track header bracket	1
10-10371	Straight arm	1
	Trolley/slide caution label	2
	Door opening warning sign	1
K75-10259	Track spacer	2
K75-10387	Trolley slider (carriage)	1
K75-10388	Front idler (chain tensioner) assembly	1
K75-10406	Drive link assembly	1
	Hardware bag with two #48 master links	1
	Hex head bolt 3/8-16 X 3/4"	12
	Hex head bolt 3/8-16 X 1-1/4"	3
	Carriage bolt 5/16-18 X 2"	2
	Serrated flange lock nut, 5/16-18	2
	Serrated flange lock nut, 3/8-16	14
	Nylon lock nut, 3/8-16	1

**For more information,  
please visit [www.devancocanada.com](http://www.devancocanada.com) or call toll free at 855-931-3334**

# INSTALLATION

## TRACK ASSEMBLY

1. Using the 3/8"-16 x 3/4" bolts and flange hex nuts provided, assemble the operator track by installing and tightening the track spacer brackets. Position the spacers evenly over the length of the track.

**NOTE:** The nylon pad on the spacer bracket should face up.

2. Using (2) 3/8"-16 x 3/4" bolts and flange hex nuts, install the front idler assembly to the second set of holes of one end of the track. Be sure the take-up bolt faces the front (toward door). Refer to the illustration below.
3. Slide the trolley carriage onto the track so that the hole of the door arm faces the front (towards door).

## OPERATOR ATTACHMENT

1. Position the track assembly on the frame of the operator so that the motor side of operator is in back (away from door).
2. Align both the first and third holes from the end of the track with holes located in the operator.
3. Connect the track to the operator by fastening four 3/8"-16 x 3/4" bolts and nuts through the frame and the end holes in track. Tighten all four bolts to secure the track to the operator.

## TROLLEY CARRIAGE / CHAIN ATTACHMENT

1. Uncoil the chain and run it up through the front idler of the chain tensioner assembly. Pull it towards the operator running it over the nylon spacer brackets and over the top of the trolley carriage. Pull the chain around the final drive sprocket on the operator and back toward the trolley carriage. Pull the release clip on the carriage and push one end of the chain through the chain slot (see illustration). Using one of the masterlinks connect the drive link to one end of the chain. Pull the drive link toward the free end of the chain and determine where to cut chain for proper adjustment. Be sure the chain tensioning bolt is loose before removing links. Using the other masterlink fasten the adjusted chain to the free end of the drive link.
2. Slide the trolley carriage back and forth past the drive link to assure that there will be no binding. Turn the chain tensioner adjustment bolt to take out most of the chain slack.
  - With trolley positioned at either end of the track, a properly adjusted chain will sag about 3" at the midpoint. If necessary, remove links from the chain to achieve proper adjustment.
3. Tie the release cord to the trolley carriage as shown.
4. Reconnect power to operator.

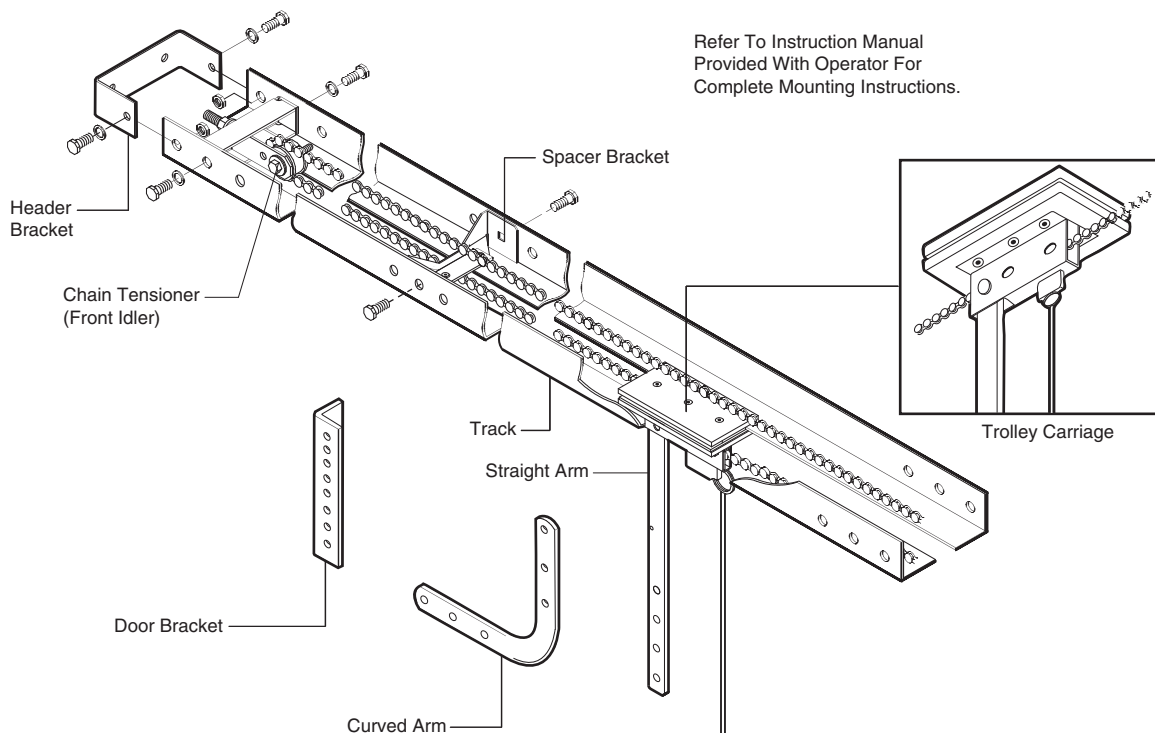

***HOW TO ORDER REPAIR PARTS***

**DEVANCO CANADA**

19192 HAY ROAD, UNIT Q  
SUMMERSTOWN, ON K0C 2E0

TOLL FREE: 855-931-3334  
[www.devancocanada.com](http://www.devancocanada.com)

**WHEN ORDERING REPAIR PARTS  
PLEASE SUPPLY THE FOLLOWING INFORMATION:**

- ✓ PART NUMBER
- ✓ DESCRIPTION
- ✓ MODEL NUMBER