

DXR-702

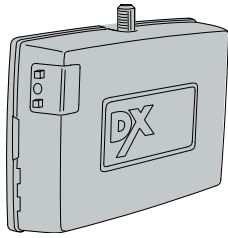

TWO-CHANNEL DIGITAL RECEIVER



Installation Instructions

For more information:
www.devancocanada.com
 or call toll free at 855-931-3334



PRODUCT DESCRIPTION

The DXR-702 is a two-channel digital receiver with two isolated relay outputs designed for use with Linear's DX Format transmitters. This receiver can be used in a variety of remote control applications. When the receiver detects a signal from a transmitter programmed into its memory, the appropriate relay output activates. The relays have four optional output configurations. When the relays are set to latch, the receiver outputs will follow the open/close door status sent from DXT-31 door/window transmitters.

In a typical installation, the receiver is connected to an alarm control panel, door strike, camera, high current relay or some other devices. Transmitters are used to activate or control the devices. The receiver should be mounted with the supplied mounting bracket indoors or inside a weather resistant non-metallic housing.

The digital DX code format features over a million possible codes. The DX transmitters are precoded at the factory to unique codes, so no field coding is required. For versatility, any transmitter can be programmed into any receiver channel. Receivers must be programmed to the transmitter's code before system testing and operation. Up to 32 transmitters maximum can be programmed into the receiver. The transmitters can be split in any number between the two receiver channels.

Receiver channel two is a special channel. If channel two memory is empty, with no transmitters programmed into it, it will report low battery signals from any channel one transmitters capable of sending them. When a low battery transmission is received, the channel two relay will latch, regardless of how the option jumpers are set. The relay will remain engaged until the channel two program button is pressed. The low transmitter batteries should be replaced before resetting the relay.

The unit can be powered from a 11-17 VDC or 12-16 VAC power source. The relays' normally open and normally closed contacts can switch up to 1 amp at 24 volts AC/DC.

Cutting jumpers select how the relays activate. Four settings are possible. Both relays will function with the same option. The factory setting causes the relays to engage for four seconds each activation. Optionally, the relays can be set to engage for one second, toggle on with one activation then off with the next, or latch engaged for door status or until reset by pressing the program button.

A nine-inch wire whip antenna screws into the receiver's antenna connector. Optionally, a remote antenna (Linear EXA-1000) can be connected to the receiver for greater radio range. The red program indicator lights during RF reception. The installer can verify that signals are being sent from transmitters and diagnose interference problems by viewing the indicator. The indicator also lights during memory programming/erasing and flashes to count the number of transmitters in memory.

DXR-702 FEATURES

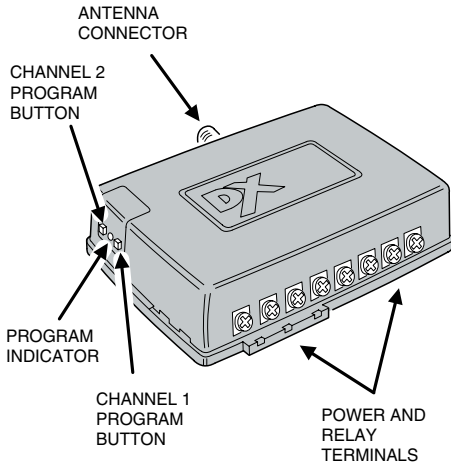

TERMINAL DETAILS

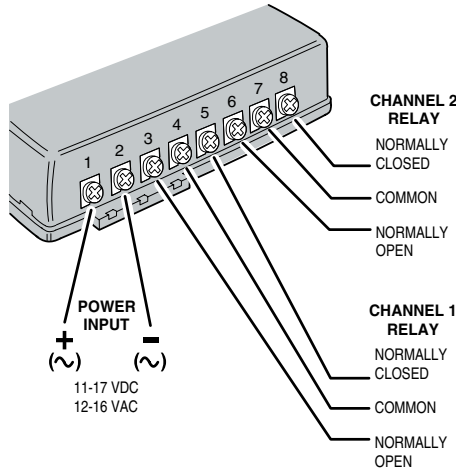

CUTTING OPTION JUMPERS

RELAY OPTIONS EFFECT BOTH RELAYS

NOTE:
 IF RELAY OPTION IS GOING TO BE CHANGED: REMOVE POWER, CUT JUMPERS, APPLY POWER, ERASE MEMORY, THEN REPROGRAM ALL TRANSMITTERS

OPEN CASE WITH SMALL SCREWDRIVER

RELAY OPTION	JUMPER WJ1	JUMPER WJ2
4 SECOND LATCH	SOLID	SOLID
1 SECOND LATCH	CUT	SOLID
LATCH UNTIL RESET ++	SOLID	CUT
TOGGLE ON AND OFF ++	CUT	CUT

BE SURE POWER IS OFF WHEN CUTTING JUMPERS

++ CAN BE RESET BY PUSHING THE PROGRAM BUTTON ONCE

NOTE:
 TO MONITOR DOOR OPEN/CLOSE STATUS WITH DXT-31 TRANSMITTERS, SET RELAYS TO LATCH
 RELAY ON = DOOR OPEN RELAY OFF = DOOR CLOSED
 OTHER TYPES OF TRANSMITTERS WILL LATCH RELAYS ON UNTIL RESET

INSTALLATION TIPS

RIGHT: CENTRALLY LOCATE RECEIVER OR ANTENNA

WRONG! TRANSMITTERS AT THE OTHER END OF HOUSE MIGHT BE TOO FAR AWAY

RIGHT: MOUNT RECEIVER OR ANTENNA AS HIGH ABOVE EARTH LEVEL AS POSSIBLE

WRONG! LOCATING A RECEIVER OR ANTENNA BELOW EARTH LEVEL WILL IMPAIR RANGE

CONSTRUCTION MATERIALS WILL EFFECT RADIO RANGE

Material	Radio Range Effect
WALLBOARD AND WOOD STUDS	90% - 100% OF FULL POWER
LIGHT CONCRETE OR BRICK	65% - 95% OF FULL POWER
CONCRETE WITH STEEL REINFORCEMENT OR METAL LATH AND PLASTER	10% - 70% OF FULL POWER

MOUNTING RECEIVER

MOUNTING NOTES:

- WHEN USING THE LOCAL WHIP ANTENNA, MOUNT RECEIVER AS HIGH AS POSSIBLE FOR BEST RADIO RANGE
- WHEN USING THE LOCAL WHIP ANTENNA, KEEP RECEIVER AWAY FROM METAL OBJECTS THAT CAN DECREASE RADIO RANGE BY SHIELDING THE SIGNAL
- IN ALL INSTALLATIONS, KEEP RECEIVER AND ANTENNA AWAY FROM MOTORS, FANS AND OTHER ELECTRICAL DEVICES THAT MAY CAUSE INTERFERENCE AND REDUCE RADIO RANGE

USE SCREWS TO ATTACH THE MOUNTING BRACKET

SNAP RECEIVER ONTO BRACKET

BRACKET CAN MOUNT IN THREE PLACES

CORNER HOLE IS SHARED FOR LOCATIONS 2 & 3

ANTENNA INSTALLATION

MODEL EXA-1000 ANTENNA

SCREW LOCAL WHIP ANTENNA ONTO RECEIVER

- OR -

USE REMOTE ANTENNA

UP TO 25 FEET OF RG-59 CABLE ALLOWED

ANTENNA NOTES:

- ANTENNA SHOULD BE MOUNTED AS HIGH AS PRACTICAL.
- KEEP ANTENNA AWAY FROM ELECTRICAL INTERFERENCE SOURCES.
- CENTRALLY LOCATE ANTENNA AMONG THE TRANSMITTERS.

TERMINAL CONNECTIONS

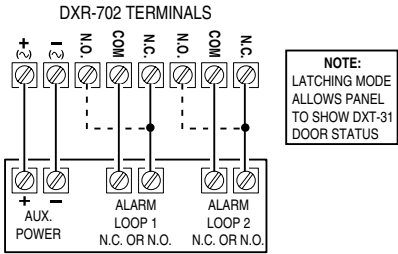

ALARM PANEL CONNECTION WITH DOOR STATUS LATCHING RELAY OPTION

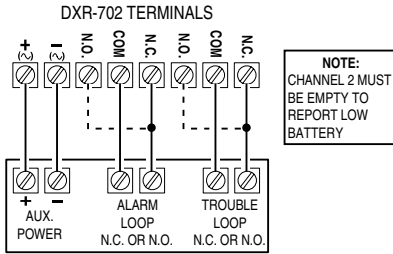

ALARM PANEL CONNECTION WITH LOW BATTERY REPORTING LATCHING RELAY OPTION

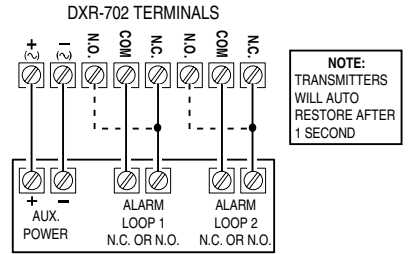

ALARM PANEL CONNECTION FOR PANIC BUTTONS 1 SECOND RELAY OPTION

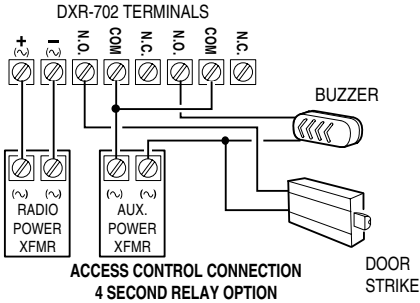

ACCESS CONTROL CONNECTION 4 SECOND RELAY OPTION

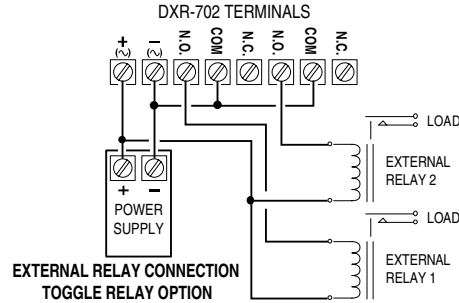

EXTERNAL RELAY CONNECTION TOGGLE RELAY OPTION

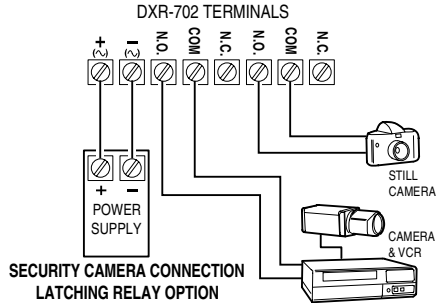

SECURITY CAMERA CONNECTION LATCHING RELAY OPTION

BUTTON AND INDICATOR FUNCTIONS

FUNCTION	PROGRAM BUTTON	PROGRAM INDICATOR
NORMAL OPERATION	RELEASES LATCHED RELAY FOR CHANNEL 1 OR 2	LIGHTS WHEN TRANSMITTER IS RECEIVED, FLASHES WHEN INTERFERENCE IS RECEIVED
PROGRAMMING MEMORY	PRESS AND RELEASE FOR CHANNEL 1 OR 2	LIGHTS FOR 3 SECONDS FOR PROGRAMMING
CHECKING MEMORY	PRESS FOR CHANNEL 1 OR 2 UNTIL BLINK AND RELEASE	BLINKS THE NUMBER OF TRANSMITTERS IN CHANNEL MEMORY
ERASING MEMORY	FOR CHANNEL 1 OR 2, PRESS AND HOLD THROUGH THE COUNT AND HOLD FOR 5 SECONDS MORE	AFTER BLINKING COUNT, A PAUSE THEN A SINGLE BLINK AS MEMORY IS ERASED (DOUBLE BLINK ON CHANNEL 2)

PROGRAMMING MEMORY

- PRESS AND RELEASE PROGRAM BUTTON FOR THE DESIRED CHANNEL.
- PROGRAM INDICATOR WILL LIGHT FOR 3 SECONDS IF THERE IS ROOM IN THAT CHANNEL'S MEMORY FOR ANOTHER TRANSMITTER (32 TRANSMITTERS MAXIMUM TOTAL ALLOWED BETWEEN BOTH CHANNELS IN THE RECEIVER).
- WITHIN 3 SECONDS, SEND SIGNAL FROM TRANSMITTER. PROGRAM INDICATOR WILL FLICKER AS SIGNAL IS RECEIVED.
- REPEAT THE ABOVE THREE STEPS FOR EACH ADDITIONAL TRANSMITTER.

MULTI-CHANNEL TRANSMITTER NOTE:

EACH RECEIVER CHANNEL CAN ONLY BE PROGRAMMED TO ACTIVATE FROM A SINGLE BUTTON ON A MULTI-CHANNEL TRANSMITTER. LEARNING THE SAME BUTTON INTO BOTH CHANNELS ACTIVATES CHANNEL ONE ONLY.

CHECKING MEMORY

- PRESS PROGRAM BUTTON FOR THE DESIRED CHANNEL AND HOLD FOR ABOUT TWO SECONDS UNTIL INDICATOR LIGHTS THEN RELEASE.
- COUNT THE NUMBER OF INDICATOR BLINKS, THIS IS THE TOTAL NUMBER OF TRANSMITTERS PROGRAMMED INTO THAT CHANNEL.

PUSH UNTIL INDICATOR LIGHTS

NOTE: DO NOT CONTINUE TO PRESS BUTTON OR MEMORY WILL BE ERASED

SYSTEM TESTING

- ACTIVATE EACH TRANSMITTER, ONE AT A TIME.
- LISTEN FOR RELAY CLICK IN THE RECEIVER.
- VERIFY THAT THE DEVICE CONNECTED TO THE RECEIVER RESPONDS AND THAT THE PROPER CHANNEL ACTIVATES.
- TEST PORTABLE TRANSMITTERS IN VARIOUS LOCATIONS TO DETERMINE SYSTEM PERFORMANCE.

ERASING MEMORY

- PRESS PROGRAM BUTTON FOR THE CHANNEL TO ERASE AND CONTINUE TO HOLD IT THROUGH THE COUNT OF THE TRANSMITTERS.
- CONTINUE TO HOLD THE BUTTON AFTER THE COUNT UNTIL THE INDICATOR BLINKS ONCE FOR CHANNEL ONE, TWICE FOR CHANNEL TWO (ABOUT FIVE SECONDS AFTER THE COUNT).
- ALL TRANSMITTERS PROGRAMMED INTO THAT CHANNEL WILL BE ERASED.

PUSH AND HOLD BUTTON FOR FIVE SECONDS AFTER THE TRANSMITTER COUNT

LINEAR LIMITED WARRANTY

This Linear product is warranted against defects in material and workmanship for twelve (12) months. The Warranty Expiration Date is labeled on the product. **This warranty extends only to wholesale customers** who buy direct from Linear or through Linear's normal distribution channels. **Linear does not warrant this product to consumers.** Consumers should inquire from their selling dealer as to the nature of the dealer's warranty, if any. **There are no obligations or liabilities on the part of Linear Corporation for consequential damages arising out of or in connection with use or performance of this product or other indirect damages with respect to loss of property, revenue, or profit, or cost of removal, installation, or reinstallation.** All implied warranties, including implied warranties for merchantability and implied warranties for fitness, are valid only until Warranty Expiration Date as labeled on the product. **This Linear Corporation Warranty is in lieu of all other warranties express or implied.**

All products returned for warranty service require a Return Product Authorization Number (RPA#). Contact Linear Technical Service at 1-800-421-1587 for an RPA# and other important details.

IMPORTANT !!!

Linear radio controls provide a reliable communications link and fill an important need in portable wireless signaling. However, there are some limitations which must be observed.

- For U.S. installations only: The radios are required to comply with FCC Rules and Regulations as Part 15 devices. As such, they have limited transmitter power and therefore limited range.
- A receiver cannot respond to more than one transmitted signal at a time and may be blocked by radio signals that occur on or near their operating frequencies, regardless of code settings.
- Changes or modifications to the device may void FCC compliance.
- Infrequently used radio links should be tested regularly to protect against undetected interference or fault.
- A general knowledge of radio and its vagaries should be gained prior to acting as a wholesale distributor or dealer, and these facts should be communicated to the ultimate users.

***HOW TO ORDER
REPAIR PARTS***

DEVANCO CANADA

19192 HAY ROAD, UNIT Q
SUMMERSTOWN, ON K0C 2E0

TOLL FREE: 855-931-3334

www.devancocanada.com

**WHEN ORDERING REPAIR PARTS
PLEASE SUPPLY THE
FOLLOWING INFORMATION:**

- ✓ PART NUMBER
- ✓ DESCRIPTION
- ✓ MODEL NUMBER