

# Addendum – **Silencio™** Apartment Style Trolley Operator

This addendum is to be used in conjunction with the Installation & Instruction Manual.

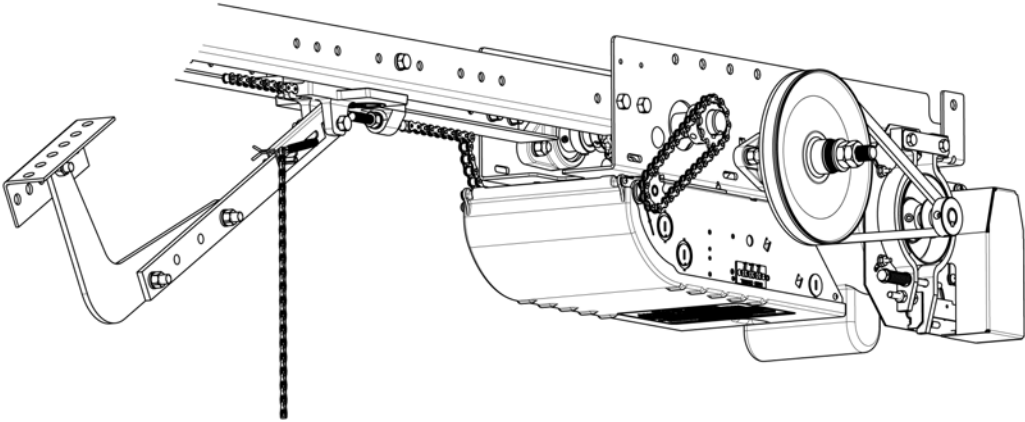

Commercial & Industrial Heavy-Duty Apartment Style Trolley Operators  
(For standard lift sectional doors with high-cycling daily frequency requirements)  
OTH-A.06 / OTBH-A.06

**4X QUIETER\***

READ AND FOLLOW ALL INSTRUCTIONS.  
SAVE THESE INSTRUCTIONS.  
GIVE TO END-USER.

Serial # \_\_\_\_\_

Model # \_\_\_\_\_

Wiring Diagram # \_\_\_\_\_

Project #/Name \_\_\_\_\_

Door #/Name \_\_\_\_\_



 The Silencio™ operators are 4X QUIETER than our “Premium Trolley Apartment” Model OTBH-A05.

For more information, please visit [www.devancocanada.com](http://www.devancocanada.com) or call toll free at 855-931-3334

## TABLE OF CONTENTS

<b>Installation Instructions.....</b>	<b>3</b>
1 General Specifications and Dimensions (OTH-A.06).....	4
2 General Specifications and Dimensions (OTBH-A.06).....	5
3 Silencio™ Apartment Style Trolley Operator Installation.....	6
3.1 Assembly Instructions.....	6
3.2 Installation.....	8
<b>Notes.....</b>	<b>10</b>
<b>Warranty.....</b>	<b>11</b>

## **Installation Instructions**

# **IMPORTANT INSTALLATION INSTRUCTIONS**



### **WARNING**

## **TO REDUCE THE RISK OF SEVERE INJURY OR DEATH TO PERSONS:**

1. READ AND FOLLOW ALL INSTALLATION INSTRUCTIONS.
2. Install only on a properly operating and balanced door. A door that is operating improperly could cause severe injury. Have qualified service personnel make repairs to cables, spring assemblies and other hardware before installing the operator.
3. Remove all pull ropes and remove, or make inoperative, all locks (unless mechanically and/or electrically interlocked to the power unit) that are connected to the door before installing the operator.
4. Installation of this door operator must be done by a qualified installer.
5. Verify that the operator is correct for type, size of door and frequency of use per the operator specifications.
6. Install the door operator at least 8 feet (2,44 m) or more above the floor if the operator has exposed moving parts. Covers or guarding, provided by the manufacturer, must be installed when the operator is mounted less than 8 feet (2,44 m) above the floor.
7. Do not connect the door operator to the source of power until instructed to do so.
8. Locate the control station: (a) within sight of the door, (b) at a minimum height of 5 feet (1,5 m) above floors, landings, steps or any other adjacent walking surface so small children cannot reach it, and (c) away from all moving parts of the door.
9. Install the Entrapment Warning Placard next to the control station in a prominent location.
10. For products having a manual release, instruct the end user on the operation of the manual release.

# 1 General Specifications and Dimensions (OTH-A.06)

SUPPLY VOLTAGE.....	115, 230 VAC single-phase, 208, 460, 575 VAC three-phase
CONTROL VOLTAGE.....	24 VAC class 2 transformer, 2 amp fuse type ACG
MOTOR.....	Continuous duty 1/2, 3/4 horsepower
DOOR SPEED.....	9" / second
NET WEIGHT (Operator only).....	71 Lbs (32 Kg)
STANDARD WIRING TYPE.....	C2 (momentary contact to open/stop and constant-pressure-to-close)
APPLICATION.....	Heavy duty for standard lift sectional doors with high cycling daily frequency requirements
DUTY.....	>100 cycles/day

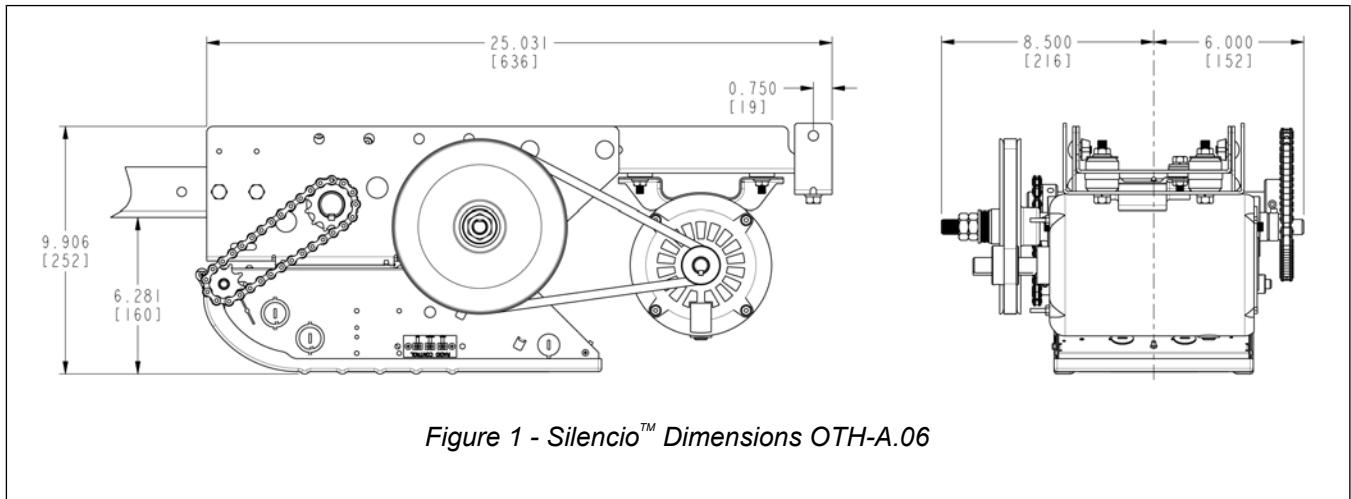

Figure 1 - Silencio™ Dimensions OTH-A.06

Table 1 - OTH-A.06 Silencio™ Operator Selection Guide

## Maximum Area in Square Feet (general guideline)

Sectional Doors					
HP	Steel 18 ga ins.	Steel 18 ga 20 ga ins.	Wood Steel 20 ga, 22 & 24 ga ins.	Alu. Steel 22 & 24 ga	Fiber Glass
1/2	196	245	314	343	392
3/4	270	319	441	490	549

## 2 General Specifications and Dimensions (OTBH-A.06)

SUPPLY VOLTAGE.....	115, 230 VAC single-phase, 208, 460, 575 VAC three-phase
CONTROL VOLTAGE.....	24 VAC class 2 transformer, 2 amp fuse type ACG
MOTOR.....	Continuous duty 1/2, 3/4, 1 horsepower
DOOR SPEED.....	9" / second
NET WEIGHT (Operator only).....	73 Lbs (33 Kg)
STANDARD WIRING TYPE.....	C2 (momentary contact to open/stop and constant-pressure-to-close)
APPLICATION.....	Heavy duty for standard lift sectional doors with high cycling daily frequency requirements
DUTY.....	>100 cycles/day

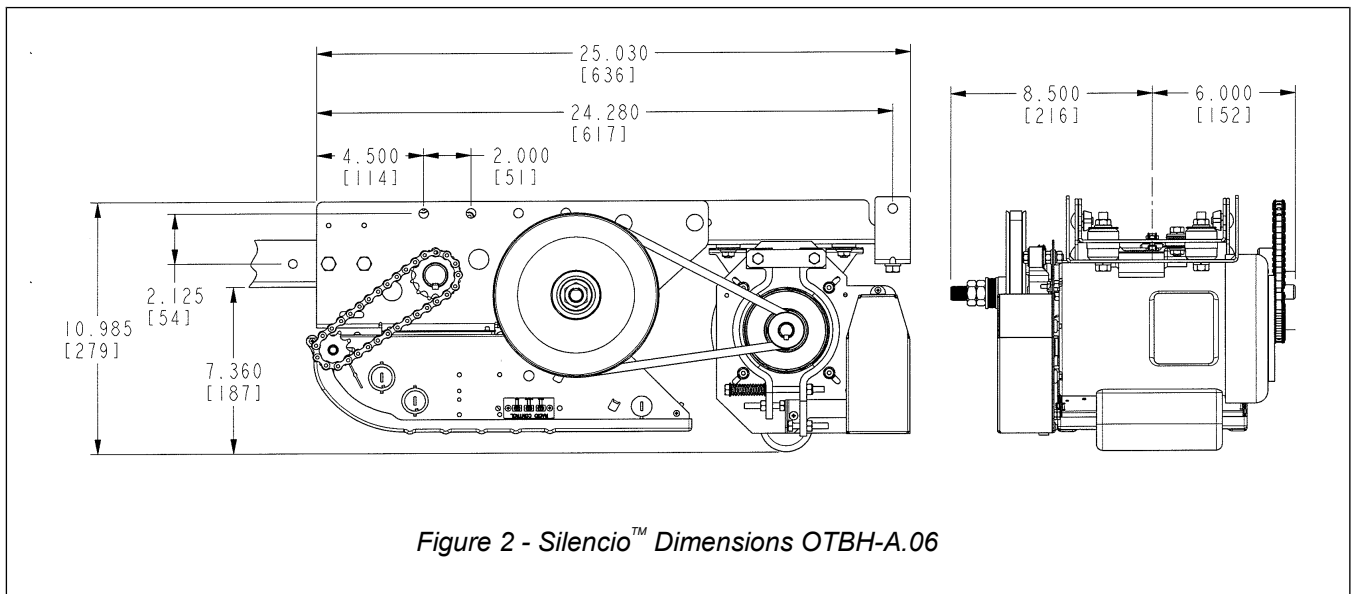

Table 2 - OTBH-A.06 Silencio™ Operator Selection Guide

### Maximum Area in Square Feet (general guideline)

Sectional Doors					
HP	Steel 18 ga ins.	Steel 18 ga 20 ga ins.	Wood Steel 20 ga, 22 & 24 ga ins.	Alu. Steel 22 & 24 ga	Fiber Glass
1/2	196	245	314	343	392
3/4	270	319	441	490	549
1	294	392	490	564	613

### 3 Silencio™ Apartment Style Trolley Operator Installation

#### 3.1 Assembly Instructions

#### CAUTION

The operator has exposed moving parts and to prevent access to the pinch points, this operator must be installed at least 8 feet (2,44 m) or more above the floor. Alternatively, covers or guarding, provided by the manufacturer, must be installed when the operator is mounted less than 8 feet (2,44 m) above the floor.

#### NOTICE

- Install the Silencio™ operator only when all openings of a horizontal slide door are guarded or screened from bottom of the door to a minimum of 4 ft (1,22 m) above the ground to prevent a 2-¼ in (57,2 mm) diameter sphere from passing through the openings anywhere in the door.

#### 1 Attach tracks to Silencio operator

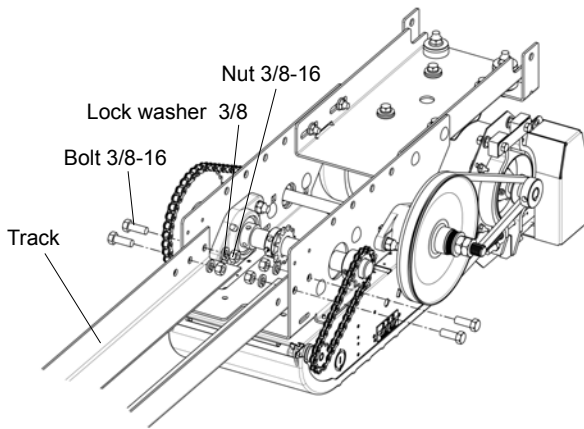

#### 2 Assemble carriage

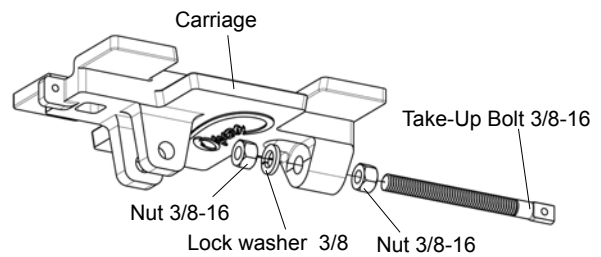

#### 3 Slide carriage on track

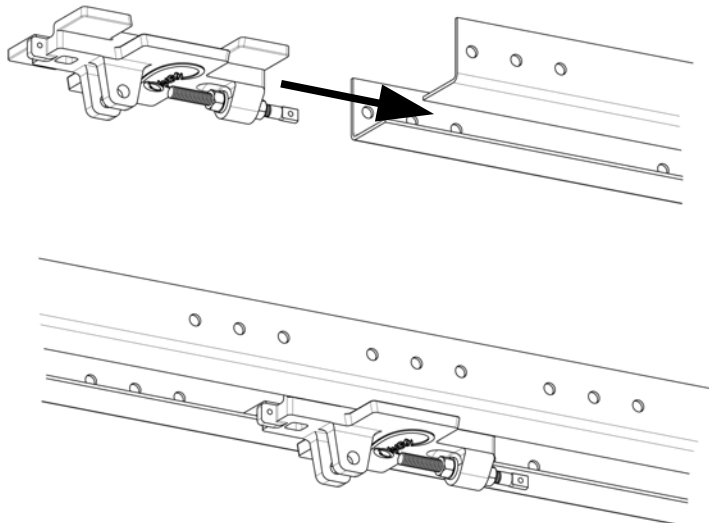

#### 4 Install spacers, sleeves and front idler

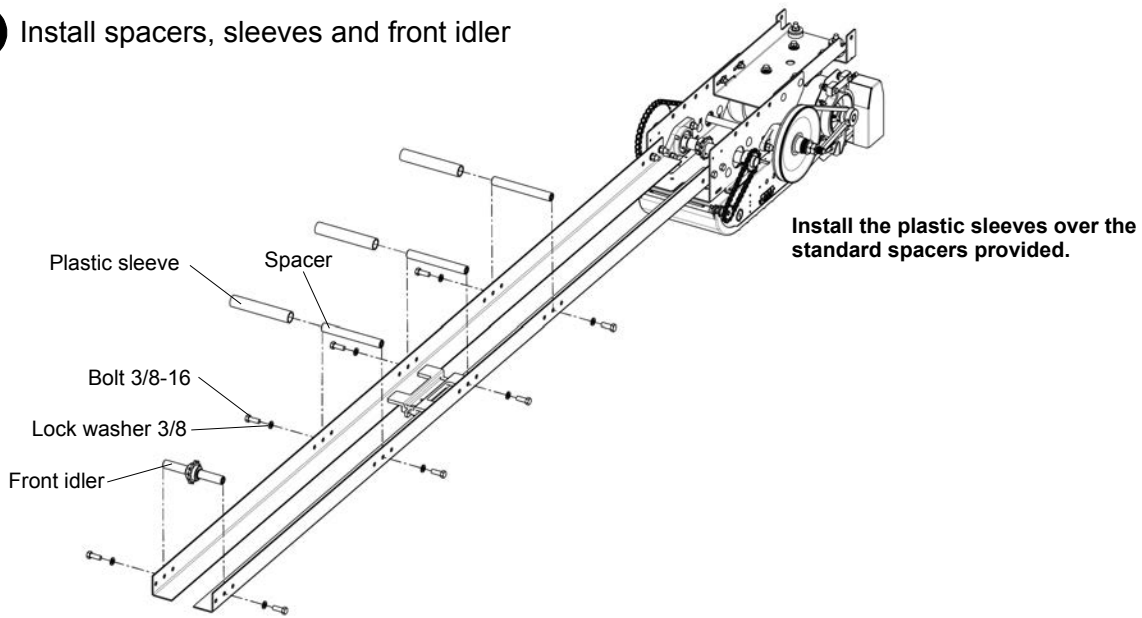

#### 5 Install chain

##### A) Attach chain to front of carriage.

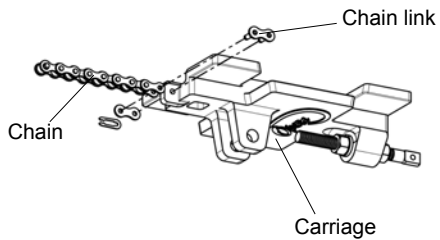

##### B) Wrap chain around front idler.

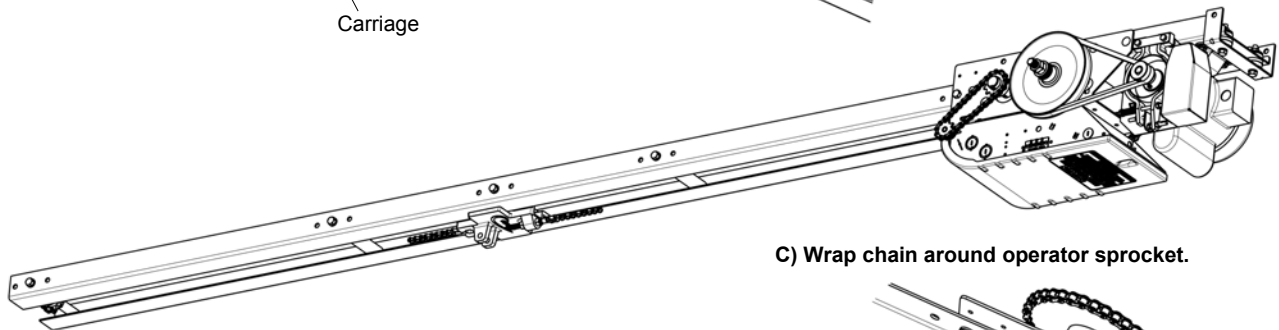
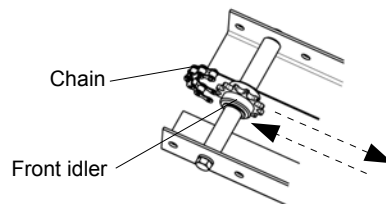

##### D) Attach chain to back of carriage.

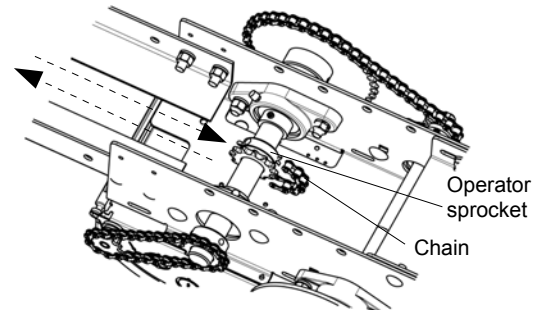
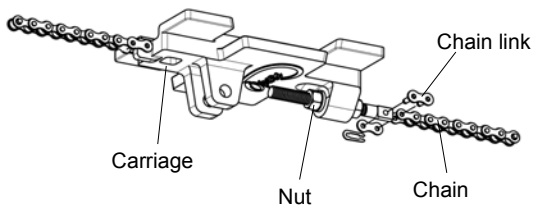

##### E) Adjust the tension on the chain.

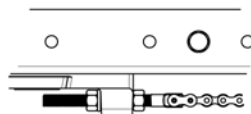

## 3.2 Installation

The Silencio™ Apartment style trolley operators are designed to be mounted directly over the center of the door. The operator tracks should clear the door by approximately 2.5". Off center mounting may be required, for example, because of potential interfering structures. It is possible to install the operator slightly off the center on torsion spring doors. Extension springs require center mounting.

### 1 Establish the center of the door

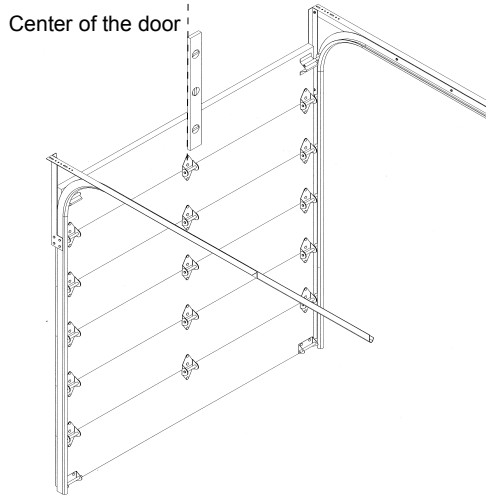

### 2 Establish the highest point of door travel

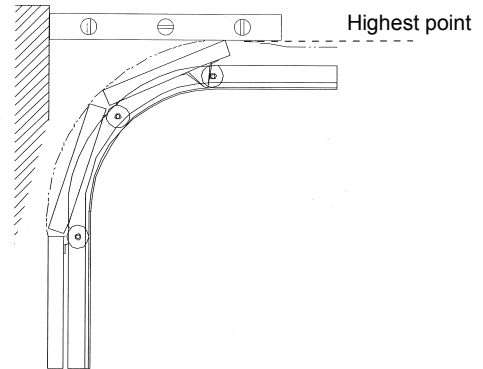

### 3 Position the U-shaped wall bracket

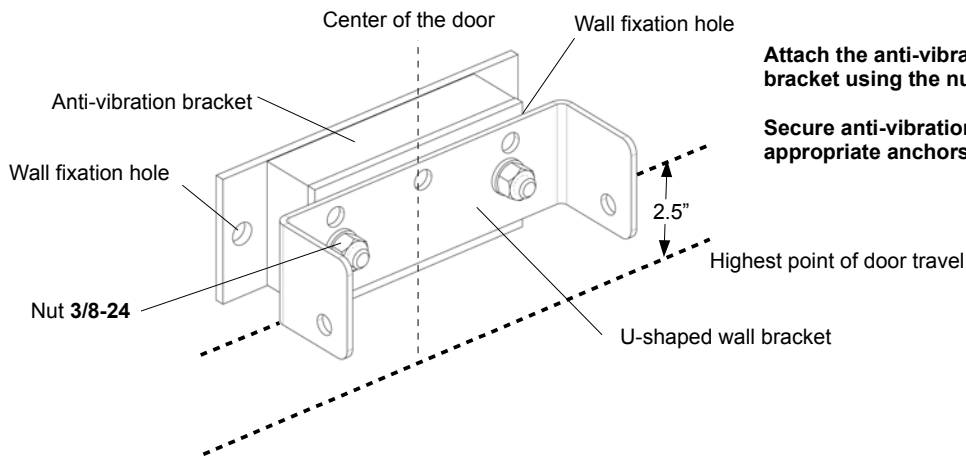

Attach the anti-vibration bracket to the U-shaped wall bracket using the nuts supplied with the bracket.

Secure anti-vibration bracket to the header using the appropriate anchors for your type of wall.

### 4 Attach tracks to U-shaped wall bracket

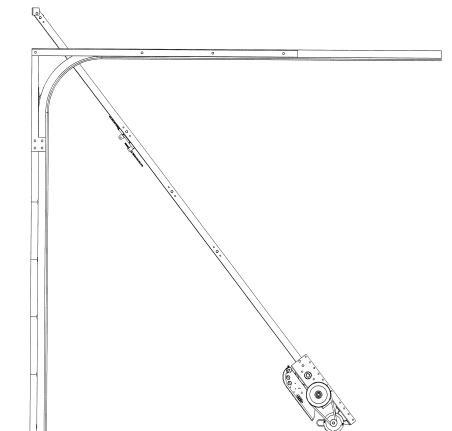

Allow the motor to rest on the floor and raise the front end of the rails and secure with the bolts and nuts (do not tighten).

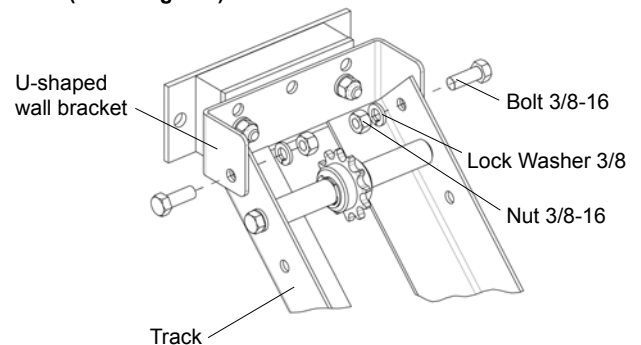



**5** Position and hang the Silencio operator

Hoist the rear of the operator to the horizontal position. Temporarily secure with rope or chain. Tighten wall bracket bolts and nuts.

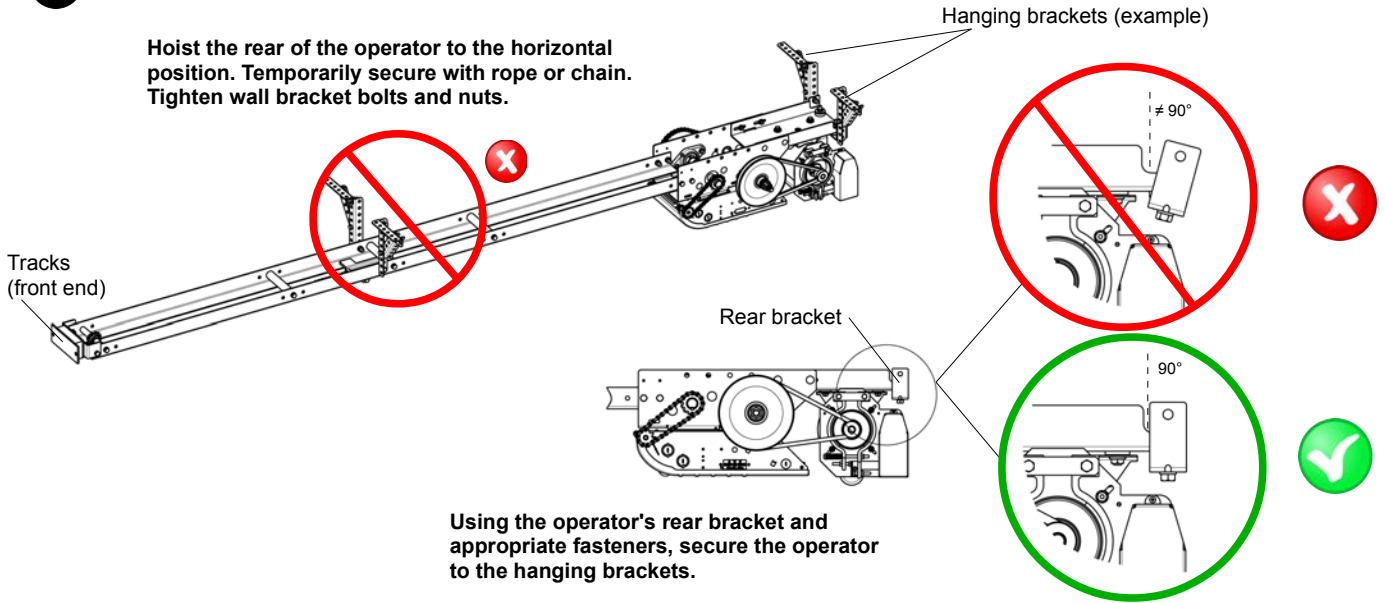

**6** Attach door arm

Assemble and attach door arm to carriage.

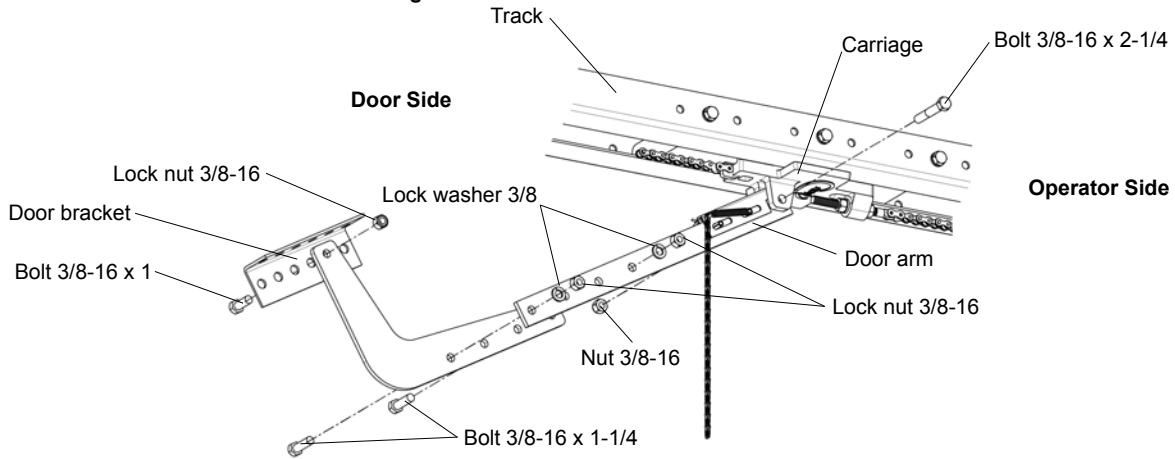

Attach door arm to door using appropriate fasteners. Mount door bracket to the center of the door.

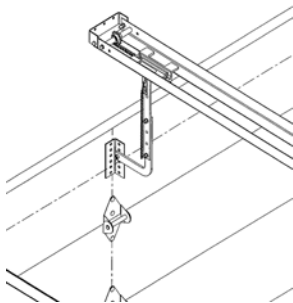

Door arm should ideally hang vertically when the door is closed.

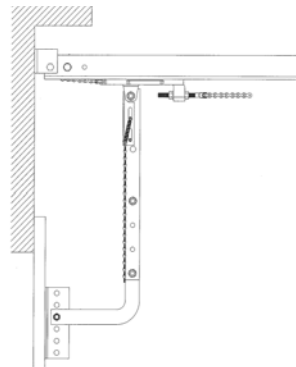

**Notes**

## **Warranty**

Manaras-Opera warrants its operators to be free from defects in material and workmanship under normal and proper use for a period of **three years** from date of invoice, unless otherwise stated. Mechanical, electrical and electronic accessories are warranted for one year from date of invoice, unless otherwise stated. Wearing parts such as clutch pads, v-belts, and brake bands are excluded from warranty.

Manaras-Opera's only obligation shall be to repair or replace defective equipment which does not conform to the warranty. Manaras-Opera shall not be liable for any injury, loss or damage, direct or consequential, arising out of the inability to use the equipment. Before using, Buyer and/or the ultimate User shall determine the suitability of the product for its intended use, and User assumes all risks and liability in connection therewith. The foregoing may not be changed except by an Agreement signed by an authorized representative of Manaras-Opera.

The articles that are replaced pursuant to the terms of this warranty shall be retained by Manaras-Opera, and the User is responsible for any freight costs relating to repair or replacement.

The foregoing warranty is exclusive and in lieu of all other warranties of quality, whether written, oral or implied (including any other warranty of merchantability or fitness for purpose).

The following are exclusions from warranty:

- If usage, product modification, adaptation or installation are not in accordance with our installation and operating instructions.
- If the product has been opened, dismantled or returned with clear evidence of abuse or other damage.
- If our written specifications are not properly applied by the Buyer when selecting the equipment.
- If our written instructions for installation and wiring of the electrical connections have not been followed.
- If our equipment has been used to perform functions other than the functions it was designed to handle.
- If Manaras-Opera equipment is used with electrical accessories (switches, relays, etc.) that have not been previously approved in writing by the Manaras-Opera Engineering Department.
- If electrical accessories and other components have been used in disregard of the basic wiring diagram for which they were designed.

All costs related to installation and reinstallation of the Manaras-Opera equipment covered by this warranty are not the responsibility of Manaras-Opera. Manaras-Opera will not be responsible for any consequential damages following installation procedures performed by the Buyer or the User. If the Buyer resells any Manaras-Opera products to another Buyer or User, it shall include all of the terms and provisions of this warranty in such resale. Manaras-Opera's responsibility to any such Third Party shall be no greater than Manaras-Opera's responsibility under the warranty to the original Buyer.

### **Returns**

No returns will be accepted without prior written authorization by Manaras-Opera. All returns must be accompanied by a Return Authorization Number issued by Manaras-Opera, and all unauthorized returns will be refused. The return shipment is to be freight prepaid by the Buyer, and under no circumstances shall the Buyer deduct the value of the returned merchandise from any remittance due. A restocking fee of 15% of the Manaras-Opera sale price will be charged for all returns not covered under warranty.

***HOW TO ORDER  
REPAIR PARTS***

**DEVANCO CANADA**

19192 HAY ROAD, UNIT Q  
SUMMERSTOWN, ON K0C 2E0

TOLL FREE: 855-931-3334

[www.devancocanada.com](http://www.devancocanada.com)

**WHEN ORDERING REPAIR PARTS  
PLEASE SUPPLY THE  
FOLLOWING INFORMATION:**

- ✓ PART NUMBER
- ✓ DESCRIPTION
- ✓ MODEL NUMBER