

# PHOTO061/061A - Photo Cells N4X



## Specifications and Installation Instructions

### WARNING

## TO REDUCE THE RISK OF SEVERE INJURY OR DEATH TO PERSONS:

1. READ AND FOLLOW ALL INSTALLATION INSTRUCTIONS.
2. Always shut OFF the main power before performing any electrical intervention.
3. Do NOT connect more than one (1) monitored entrapment protection device simultaneously on the MONIT terminals.
4. Photo cells must be installed facing each other across the door's path within 6" (15 cm) of the plane of the door and the beam no more than 5-3/4" (14,6 cm) above the floor).

### Contents

Article No.	Components	Description	Specifications
<b>PHOTO 061</b> <b>Monitored External Entrapment Protection Device</b>  Used to safeguard doors according to the requirements of UL325	 <p><b>Optical Sensor</b></p>	<ul style="list-style-type: none"> <li>◆ Transmitter (Tx) and Receiver (Rx) sensor pair for use as monitored photo cells.</li> </ul>	<ul style="list-style-type: none"> <li>➔ 2-wires for transmitter. 2-wires for receiver. Can be mixed and matched.</li> <li>➔ Connects to specific MONIT terminal on electronic control board (BOARD 070M).</li> <li>➔ Through beam type.</li> </ul>
	 <p><b>Bracket (Adaptor)</b></p>	<ul style="list-style-type: none"> <li>◆ Pair of flexible brackets (adaptors) for use as monitored photo cells.</li> </ul>	<ul style="list-style-type: none"> <li>➔ Use in industrial environments.</li> <li>➔ Submersible and impact resistant.</li> <li>➔ Flexible design withstands mechanical impacts. Realigns after impact.</li> <li>➔ Plastic lens used on receiver.</li> <li>➔ Adjustable without the use of tools.</li> <li>➔ Includes L-shape metal mounting brackets and hardware.</li> </ul>

**For more information, please visit [www.devancocanada.com](http://www.devancocanada.com)  
or call toll free at 855-931-3334**



# PHOTO061/061A - Photo Cells N4X

## Specifications and Installation Instructions

### Technical Data – Photo Cells

Protection Class	NEMA 6 Sensors
Operation Temperature	-15 °F to + 170 °F
Housing Material	Polypropylene (PP)
Housing Diameter	3/4"
Housing Length	1-3/8"
Signalling Cable	PVC Insulation, 2 x 22 AWG
Length of Signalling Table	Max. length from sensors to signal processing unit: ~650 Ft
Length of Cable	3 Ft (PHOTO061), 50 Ft (PHOTO061A)
Voltage	+6 VDC to +40 VDC

### Technical Data – Brackets (Adaptors)

Protection Class	NEMA 4X Brackets (Adaptors)
Color of the Sealing Compound	Transmitter: Grey, Receiver: Black
Sealing Compound	Polyurethane (PU)
Operation Temperature	-15 °F to +170 °F
Housing Material	Thermoplastic Elastomer (TPE)
Range / Working Distance	Up to 45 Ft

### Dimensions

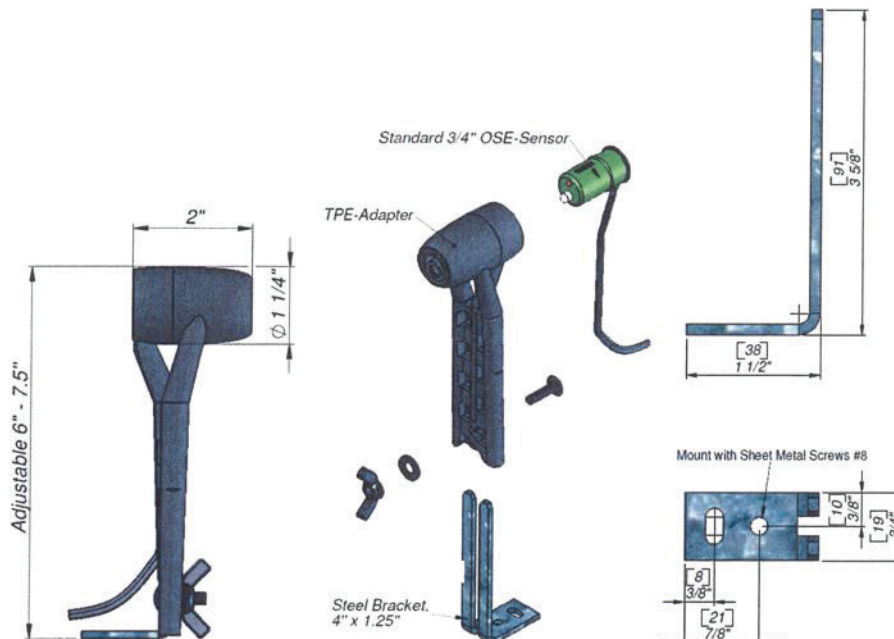

### Installation Instructions

- 1** Plug sensors into flexible adapters

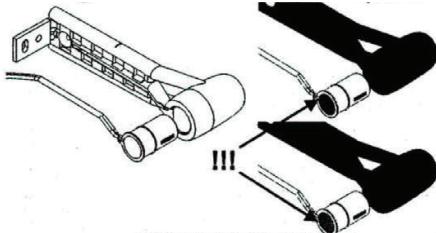

- 2** Mount the bracket next to the door opening  
The angle can be adjusted as required.

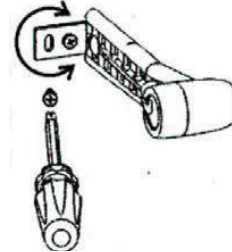

- 3** Loosen the wingnut to adjust adaptor height

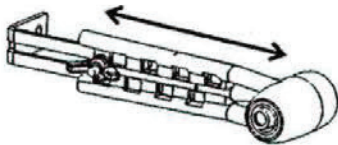

- 4** Wire the receiver and the transmitter to the operator's electronic control board terminals

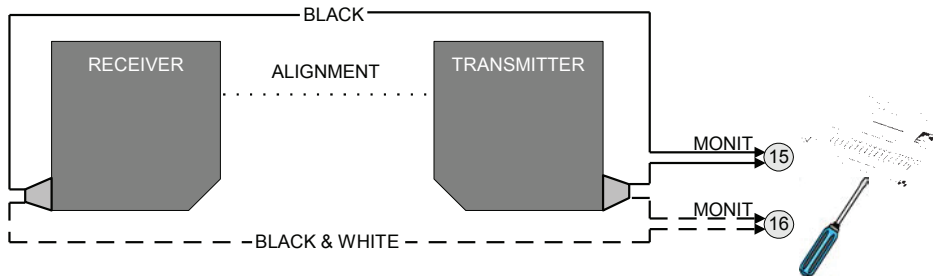

- 5** Adjust photo eye by changing the angle and height of adaptor  
Use the LEDs for alignment and troubleshooting.

### Photo Eyes – LED Status Descriptions

Red LED	Green LED	Status
ON	ON	Normal operation
OFF	OFF	No power, check wiring
2 x Blink	ON	Poor alignment / Obstructed beam / Rx defective
2 x Blink	OFF	Check power and wiring to Rx / Rx defective
3 x Blink	ON	Rx receiving sunlight interference / Other interference

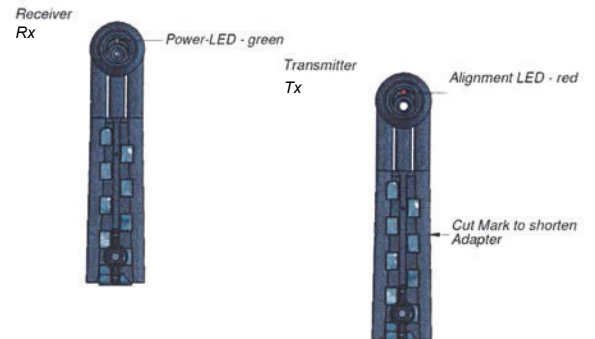

***HOW TO ORDER  
REPAIR PARTS***

**DEVANCO CANADA**

19192 HAY ROAD, UNIT Q  
SUMMERSTOWN, ON K0C 2E0

TOLL FREE: 855-931-3334

[www.devancocanada.com](http://www.devancocanada.com)

**WHEN ORDERING REPAIR PARTS  
PLEASE SUPPLY THE  
FOLLOWING INFORMATION:**

- ✓ PART NUMBER
- ✓ DESCRIPTION
- ✓ MODEL NUMBER