

The CPT Sensing Edge

The Premier "Quick-Fix Service Edge"

Applications

DOORS

- **Sectional Doors**
- **Rolling Grilles**
- **Counter Shutters**

GATES

- **Barrier Gate Arms**
- **Sliding Gates**

The CPT Sensing Edge has been developed to provide an efficient and effective **Quick-Fix** safety solution for a variety of door and gate applications. Manufactured from PVC Alloy and available in 50 feet lengths, CPT210 can be easily stored for assembly in the field.

The CPT-210 is the ideal replacement sensing edge solution and includes molded End Plugs (with encapsulated monitored or non-terminated configurations) providing a secure and reliable safety edge, for both door and gate applications.

DESIGN FEATURES:

- Build in the field to desired length
- Unique end plug design
- Weather resistant - weather seal
- Easy to install - Cut to fit

TECHNICAL SPECIFICATIONS:

Color: Black

Extrusion Length: Extruded Flexible PVC 50 ft.

Sensing Edge Size: 1 3/32" H x 7/8" W

Sensitivity: nominal 3-5 lbf

Lead Wire: 18" - 22 gauge

Wire Outlet Location: Universal

Wire Configuration: N.O. (available in N.C. - Contact Factory)

Electrical Max: 24V AC/DC

Contact Element: "CPT" Conductive Polymer Technology

Mounting Channel: High-density PVC

Electrical Interface: Sealed Module - Provides seamless connection to "Logic" or "Relay" type operators

Warranty: 2 years on manufactured components only
Failure due to site workmanship is not covered.

ANSI/UL325 Recognized Component



Flexible PVC Extrusion and End Plug

FUNCTIONAL BENEFITS:

- Touch Sensitive Signalling
- Small Profile Guards Pinch Points
- Labor Saving: Assembles in Minutes
- Reliable: ANSI/UL325 Recognized Component



For more information, please visit www.devancocanada.com
or call toll free at 855-931-3334



Model # CPT-210

SensingEdge

Installation

Place appropriate CPT-210 mounting channel in desired location. Drill 1/8" holes through channel and into mounting surface every 24". Attach channel to surface with screws. Slide CPT-210 Sensing Edge into channel and wire to controls.

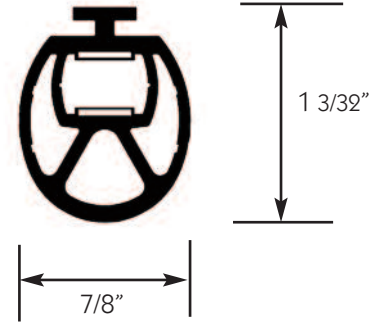

CPT-210 Extrusion

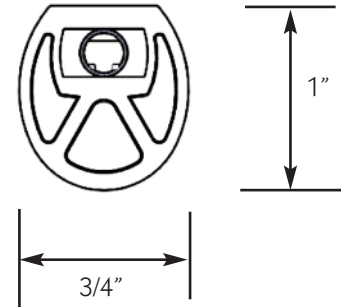

CPT-210 End Plug

Care of the CPT-210. . .

Minimum care is required for the CPT-210 since it is manufactured with only the most durable materials and the highest quality control standards. However, Sensing Edges should be examined regularly for cuts or punctures which could damage internal components. Check wiring to be sure connections are secure. When properly maintained, the CPT-210 offers years of trouble free operation.

Mounting Channels

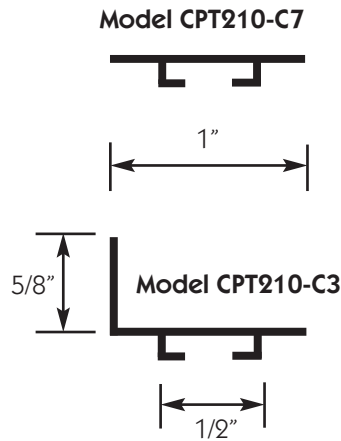

CPT210_Spec_20150223

For more information, please visit www.devancocanada.com
or call toll free at 855-931-3334