

# LC36M

Monitored Light Curtain

---



**PRODUCT GUIDE**

For more information, please visit [www.devancocanada.com](http://www.devancocanada.com)  
or call toll free at 1-855-931-3334

**LiftMaster**

# LC36M

## Monitored Light Curtain



### Features

**36 inches of effective height coverage**

Provides a plane of protection that offers standalone monitored entrapment protection.

**Color-coded transmitter and receiver**

For easy identification (black and red electrical strain reliefs).

**Multiple sets of LC36M curtains**

Can be mounted on a door providing coverage flexibility (see instruction manual for requirements).

**Maximum door width of 33 ft.**

Ensures coverage for most commercial doors.

**Eight (8) LEDs per side and 22 cross-beams**

Produce an invisible curtain of infrared light for maximum detection capability.

**Solid LED diagnostic lights**

Indicate correct sensor alignment, simplifying installation.

**Green diagnostic LED**

Flashes when interrupted, providing visible interrupt detection.

**Water-resistant performance**

IP67-rated to withstand hose-directed water, is temporarily submersible up to one meter and withstands sand and dust ingress.

### Engineered for safety

The Monitored Light Curtain provides primary entrapment protection with eight optical sensors and 22 light beams.

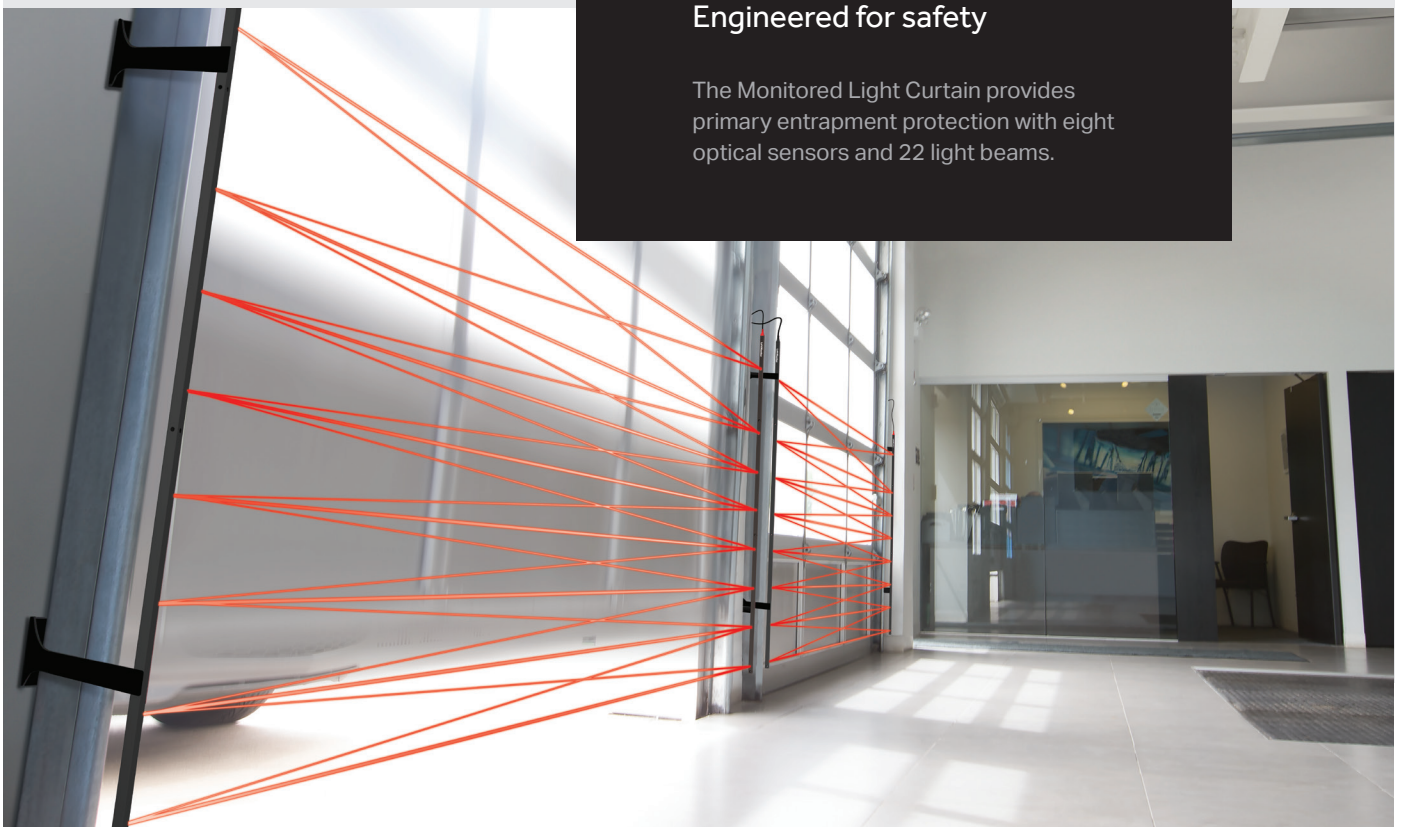



### Control and protect

Prevent vehicle, taller equipment and door damage to improve the uptime of your operations with a monitored curtain of protection that will stop and reverse a closing commercial door before collisions occur. 36 inches of vertical coverage keeps your customers, employees and equipment safe.



### Seamless door system

A primary entrapment device ideal for use in auto dealerships, providing expanded protection for vehicles with taller bumpers, open tailgates and high ground clearance. Partner with a myQ® commercial operator to enable Smart Facility Access and create a connected ecosystem.

## Installation Options

The proper installation and use of appropriate entrapment protection sensors reduces the occurrence of accidents and the exposure of installers and customers to liability.

Along with the LC36M Monitored Light Curtain, LiftMaster also offers the non-monitored LC-36A. This is an ancillary entrapment protection device that works with a primary device in maintaining compliance with UL 325. Additional monitored devices are the LiftMaster CPS-UN4, CPS-RPEN4, CPS-OPEN4 and CPS-U.

#### Option A

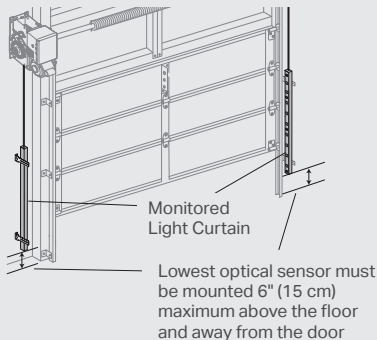

#### Option B

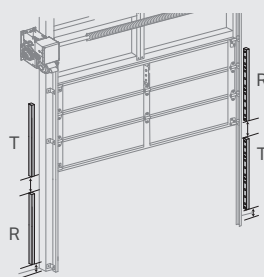

#### Option C

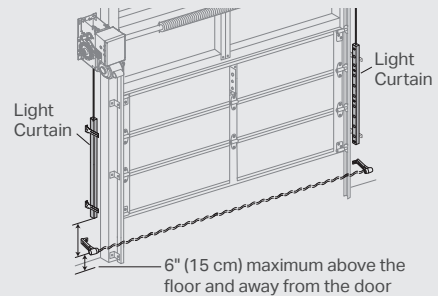

T = Transmitting Monitored Light Curtain, R = Receiving Monitored Light Curtain

## Specifications

### Power

- 22-24VAC/DC (power supplied by operator); 100MAPS Power Supply is an optional power source for use with LiftMaster Logic 5.0 operators and HCTDCUL.
- The 100MAPS is required for use with other compatible LiftMaster Commercial Operators.

### Technical Specifications

- Maximum Alignment Range: 33 ft./10.1m
- Min. Alignment Distance: 36 in. (3 ft.)/0.91m
- Corrosion resistance supported by black anodized aluminum housings, power-coated brackets, zinc-plated mounting hardware and plastic electrical strain relief and crosstalk blocking shield; rated for indoor use only
- Temperature Range (Operating) -40°C to +60°C (-40°F to 140°F)
- Monitored (suitable for Primary Entrapment Protection), 2-Wire Color Coded Sensors (Red electrical strain relief = Receiver; Black electrical strain relief = Transmitter)
  - Transmitter: Amber diagnostic LED
  - Receiver: Green diagnostic LED

### Operator Compatibility

- LOGIC 5.0, Medium-Duty, DDO8900W/LJ8900W/LJ8950W/ATSW, VFOH, HPH1/HPH2, HCTDCUL, Fire Door, Egress

### Shipping Details

- Carton Dimensions: 2.5" H x 2.75" W x 49" L
- Contents: 1 transmitter with #22AWG color-coded power wiring, 1 receiver with #22AWG color-coded signal and power wiring, mounting hardware that includes 4 mounting brackets (GA10 with 10" overall length for use with up to 3" door track/rollers), 6 electrical connectors for signal and power wiring, 1 crosstalk blocking shield and installation instructions
- Weight: 5 lbs.

### Product Dimensions

Product	0.63" W (1.60 cm)	0.47" H (1.19 cm)	47" L (119.38 cm)

### Warranty

- 2-Year Limited Warranty

## Wiring Diagrams

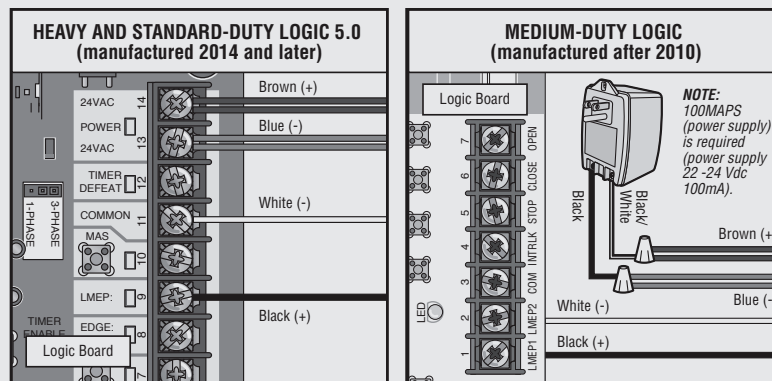

These are sample wiring diagrams. Please see our website for additional drawings and specifications.

**NOTE:** LiftMaster® offers a full range of UL 325 compliant accessories and door operators, powered by myQ®, to improve protection around the door. For real-time visibility of all your doors, connect to myQ Smart Facility for reporting and analytics to make data-driven decisions that impact workforce safety.