

Product Specification Sheet



RAPIDO™ RSH

JACKSHAFT OPERATOR FOR
FAST SECTIONAL DOORS

STANDARD FEATURES

- **Electrical Supply:**
120V 60Hz nominal, mono-phase.
- **Motor:**
60Hz high starting torque, continuous-duty, 3 phase switchless motor, open drip proof, protected against overload.
- **Reduction:**
First step in reduction 5L/Bx section cogged V-belt drive, additional steps by chain and sprockets. Input shaft is 3/4", supported by cast iron flanged pillow block bearings. Output shaft is 1" with 1/4" keyway, supported by cast iron flanged pillow block bearings. Output shaft speed: 88 rpm standard.
- **Clutch:**
Friction type, positioned on input shaft, easily adjustable from outside.
- **Drive:**
#50 roller chain with sprockets selected for an opening door travel between 12"/sec to 24"/sec.
- **Brake:**
Electrically activated drum-band type solenoid brake.
- **Manual Operation:**
Emergency manual chain hoist. Floor level chain hoist engaging device with electrical cut-out. An electrical interlock automatically disconnects power to the motor operator when chain hoist is engaged. Hoist on right is standard.
- **Electrical Enclosure:**
All electrical components are in a Nema 1 enclosure. Hinged electrical enclosure cover.
- **Limit System:**
Rotary-type oil-impregnated steel cams, commercial grade switches. Limit shaft is supported by self-lubricating bronze bushings for increased precision. Remains in time when there is a manual operation or after the motor has been removed.
- **Accu-cam® Feature:**
Precise and quick one-handed adjustment of the limits.
- **Corrosion Protection:**
Frame and control enclosure protected by baked on, long lasting enamel finish. Polymer control box cover. All shafts protected by yellow chromate coating.
- **Mounting:**
Wall or shelf mounted on the right or on the left of the door. For indoor use only.
- **Temperature Range:**
Working temperature between 0°C to 40°C (32°F to 104°F).
- **Shipping Weight:**
Approx. 105 Lbs - 48 Kg.
- **Warranty:**
2 Years.

Manages Soft-Starts and Soft-Stops

Improves the longevity of the complete door system

On-Board Control

Control board and speed managing device

Single Phase Input Power / Switchless Motor

Cast Iron Pillow Block Bearings

Flanged pillow block bearings on the input and output shafts

Accu-cam® Limit Feature

For precise and quick one-hand limit setting adjustments



The Rapido™ RSH is a high-speed heavy-duty V-belt drive industrial operator designed for use on properly counter-balanced standard, high and vertical lift sectional doors, weighing a maximum of 750lbs.

The Rapido™ RSH offers up to 2X the speed of the standard jackshaft operator while smoothly managing Soft-Starts and Soft-Stops, therefore reducing the wear and tear of the complete door system.

The operator can be wall or shelf mounted on either side of the door. It incorporates a chain hoist for manual operation, with a floor level engaging device.

The Manaras-Opera control is based on its legendary Electronic Control Board which delivers high performance and reliability while providing on-board control plus speed managing features.



When you think
Commercial Door OPERATORS,
just think OPERA.

For more information:
www.devancocanada.com
or call toll free at 855-931-3334

OPERATOR CONTROL

CONTROL OPTIONS

• ECB Units (BOARD 070):

24Vdc relaying circuit with a 40VA class II transformer, non-volatile memory. Features available: On-board radio receiver, 1s delay on reverse, programmable maximum run timer, mid-stop, timer to close (suspension possible from floor level), independent input loop terminal, advance close system, test buttons and reverse wiring detection. Operating mode selectable on site: C2, B2, D1, E2, T or TS.

• "M" Version:

Provides the monitoring of Primary External Entrapment Protection Devices. Includes monitored Nema 4X photo cells (PHOTO 061 standard). In this mode, Ancillary Entrapment Protection Devices (optional) may be used to supplement primary entrapment protection, such as non-monitored photo cells, 2-wire non-monitored sensing edges and pneumatic sensing edges.

• "E" Version:

No monitoring function.

MAIN OPTIONS

• Control Accessories:

Terminal strip allows for the connection of 3-button stations (one supplied with the operator), non-monitored sensing edges, non-monitored photo cells, one push-button radio control (external strip), ceiling pull switches, key switches, loop detectors, external interlocks and universal auxiliary output module. 2A fuse protected 24VAc output is available for accessory power supply.

• Control Modifications:

Alternate control available with separate control panel, optional separate brake resistor, etc... consult inside sales.

• Environmental Modifications:

Available for Nema 4/12 type applications with separate control panel, etc... consult inside sales.

• Mechanical Accessories:

Wall mounting bracket, chain spreader, etc... consult inside sales.

• Mechanical Modifications:

Left hand chain hoist, etc...consult inside sales.

SUGGESTED APPLICATIONS

- First Responder / Emergency Vehicle Facilities
- Automotive Dealerships / Transportation Facilities
- Airports / Military Facilities
- Energy Management / Energy Efficient / LEED Buildings

** For additional specifications and in order to optimize the operator's performance, please contact our inside sales department for assistance in selecting the appropriate hardware kit for your application. **

DIMENSIONS

Clearance: Side room required 16" (460 mm)

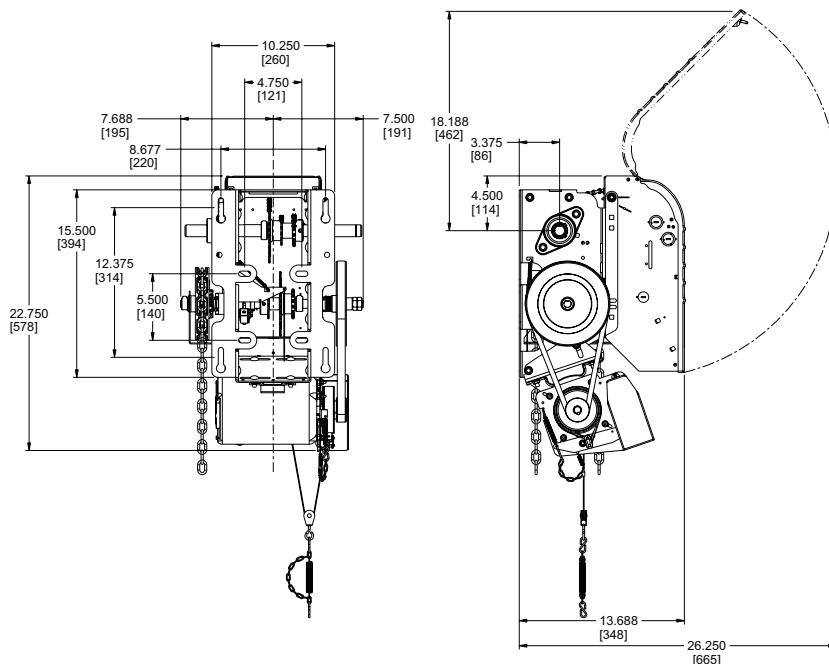

OPERATOR RANGE

Current Consumption (Amp.)

Horse Power	120 V 1 Ph	General Guideline
1	16.0	

