

INSTALLATION

CAUTION

- To AVOID damaging gas, power or other underground utility lines, contact underground utility locating companies BEFORE digging more than 18 inches (46 cm) deep.
- DO NOT touch the heater when switch is on, heater may be hot.
- To prevent damage to the operator or gate, DO NOT drive the limit (nuts) actuators on the shaft past their normal positions.

STEP 1

INSTALL THE OPERATOR

Check the national and local building codes before installation.

INSTALL WITH ADJUSTABLE RAILS

1. Locate and anchor two posts made of 3" (7.6 cm) outer diameter heavy walled pipe. Posts should be parallel and square to the gate.
2. Locate electrical conduit, as required, prior to pouring concrete.
3. Slide the four 3" (7.6 cm) clamps (provided) into the rails on the sides of the operator.
4. Slide the posts into the clamps and tighten the screws on the clamps to secure the operator.

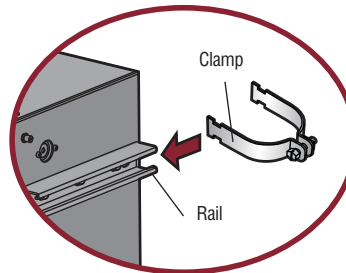
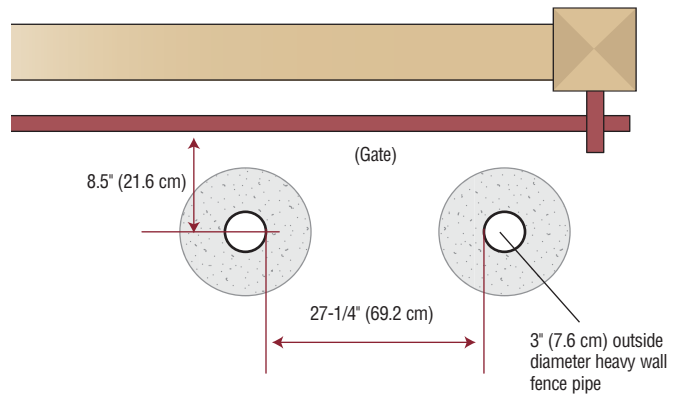

Drive and idler sprocket toward gate side

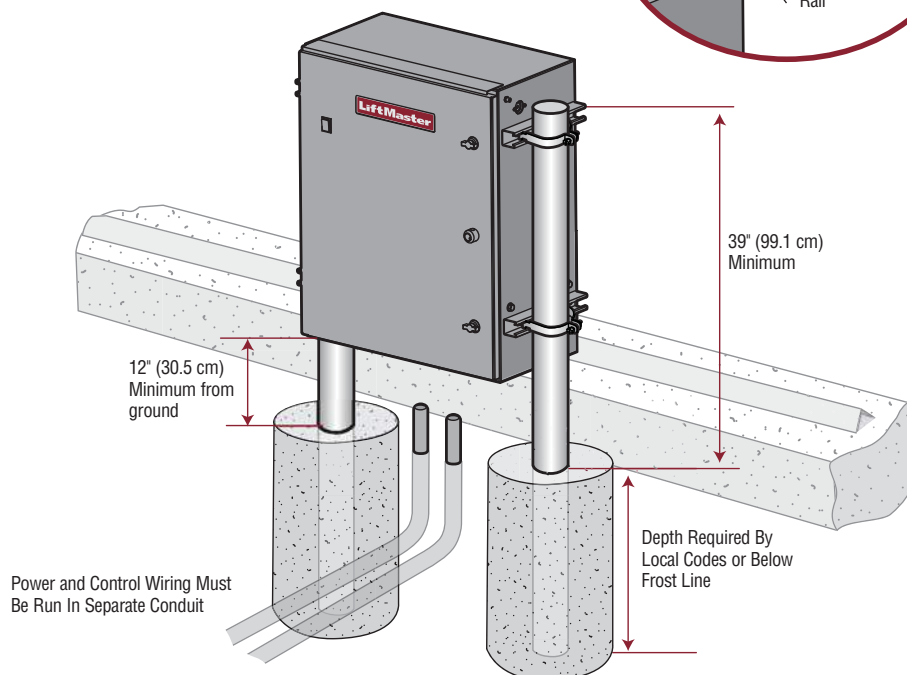

INSTALLATION

STEP 1 (continued)

INSTALL THE OPERATOR

Check the national and local building codes before installation.

INSTALL WITHOUT ADJUSTABLE RAILS

NOTE: The rails will have to be removed for retro-fit installations.

1. Locate and anchor two posts made of 3" (7.6 cm) outer diameter heavy walled pipe. Posts should be parallel and square to the gate.
2. Locate electrical conduit, as required, prior to pouring concrete.
3. Remove the rails from the sides of the operator.
4. Secure operator to posts using four 3" (7.6 cm) U-bolts and hardware.
5. Fill any empty holes on the side of the operator with the extra bolts from the rails.

