

Owner's Manual contains:
Installation, operating,
maintenance & warranty
instructions.

Synergy 360

Synergy 370

Synergy 380

Carriage House & Wind-Loaded
Garage Door Operator System
Install on Sectional Doors Only



Synergy 360
Synergy 370
Synergy 380

Synergy 360
Synergy 370

For more information:
www.devancocanada.com
or call toll free at 855-931-3334

Marantec Accessories

Convenience in many forms. All of Marantec's transmitting and receiving devices operate on 315MHz and are HomeLink compatible. Extension accessories such as LED lighting or the optional integrated battery backup system can be activated through simple plug-and-play connections.



Transmitters

Keypad

BBU

LEDS

External Receiver

Photo Eyes

Individualized features and customized comfort can be achieved with Marantec's extensive range of accessories. An extra transmitter or a wireless keyless entry system with expanded features, an integrated battery back-up unit for providing operator functionality during a power outage. Or how about LED lighting extension kits to enhance the lighting in your garage? Whatever accessories you are looking for, we have them available.

OWNER'S MANUAL CONTENTS

1.	INTRODUCTION	5
2.	ADVANCED FEATURES	5
3.	IMPORTANT SAFETY INFORMATION	5
4.	TOOLS	6
5.	GARAGE	6
6.	OPERATOR PACKAGE CONTENTS	8
7.	IMPORTANT INSTALLATION INSTRUCTIONS	9
8.	INSTALLATION STEPS	10
8-1.	MEASURE AND MARK DOOR AREA	10
8-2.	INSTALL HEADER BRACKET	10
8-3.	INSTALL DOOR BRACKET TO DOOR	11
8-4.	RAIL ASSEMBLY	11
8-5.	2-PIECE RAIL ASSEMBLY	12
8-6.	ATTACH RAIL TO OPERATOR HEAD	13
8-7.	ATTACH RAIL TO HEADER BRACKET	14
8-8.	POSITION OPERATOR FOR MOUNTING	14
8-9.	MOUNT OPERATOR TO CEILING	15
8-10.	CONNECT ARM TO DOOR AND TROLLEY	15
8-11.	RAIL BUMPER INSTALLATION	16
8-12.	CHECK EMERGENCY RELEASE	16
8-13.	INSTALL PHOTO EYE SAFETY SYSTEM	17
8-14.	INSTALL WALL CONTROL PANEL	18
8-15.	CONNECTING WIRES TO OPERATOR	18
9.	CONTROL UNIT CONNECTIONS	19
10.	CONNECT TO POWER	20
11.	SYSTEM SET UP	20
12.	ADVANCED SETTINGS	22
13.	REMOTE CONTROLS	25
13-1.	TRANSMITTER	25
13-2.	WIRELESS KEYLESS ENTRY SYSTEM (OPTIONAL ACCESSORY)	27
14.	OPERATION OF YOUR OPERATOR	28
15.	HOMELINK® TRANSCEIVER	29
16.	TEST SAFETY REVERSAL	30
17.	ALIGN AND TEST PHOTO EYE SENSORS	30
18.	APPLY LABELS TO INSIDE OF GARAGE	30
19.	ATTACH OWNER'S MANUAL TO WALL	30
20.	IMPORTANT SAFETY INSTRUCTIONS	31
21.	TENSION ADJUSTMENT	31
22.	RAIL LENGTH ADJUSTMENT - FOR PROFESSIONAL INSTALLERS ONLY	32
23.	RAIL PARTS (HEAVY DUTY RAIL)	32
24.	RAIL PARTS (STANDARD RAIL)	33
25.	OPERATOR PARTS	34
26.	ACCESSORIES	35
26-1.	LED EL 300	35
26-2.	EXTENSION BRACKET KIT	36
26-3.	PERMANENT WIRING	36
26-4.	ENERGY PACK 100 (BATTERY BACKUP)	37
26-5.	AUTOMATIC TIMER-TO-CLOSE ATC 100 KIT	40
26-6.	TROLLEY EMERGENCY RELEASE SYSTEM	43
27.	TROUBLESHOOTING - FOR PROFESSIONAL INSTALLERS ONLY	45
28.	MAINTENANCE AND ADJUSTMENTS	46
29.	LIMITED PARTS WARRANTY	46
30.	WARRANTY LIMITATIONS, CLAIMS AND SERVICE	48
31.	REGISTRATION	48
32.	WARRANTY SERVICE	48

1. INTRODUCTION

Congratulations on purchasing your Marantec® Synergy Garage Door Operator System, the most innovative operator available today. This stylishly designed digital operator with a wide range of accessories is engineered to provide the smoothest, quietest and safest operation to compliment any application. Advanced technology results in the operator being capable of easily moving almost any properly balanced sectional door, and at the same time providing state-of-the-art safety features to detect obstructions and to stop and reverse the door, thus helping to protect persons and property near the door.

2. ADVANCED FEATURES

This operator includes numerous state-of-the-art features to provide you, the user, with years of trouble-free, convenient, and safe use of your automatic garage door operator.

- **Advanced Digital Operating System EOS (Easy Operating System):** The EOS digital system provides an user friendly system set up. The EOS system requires only the initial set up parameters. All other operating parameters are learned and set automatically by the system. In addition, the system optimizes all parameters with every cycle for a more efficient operation by the GDO. This shorter parameter set up provides a quicker and more efficient installation.
- **New LED Lighting System:** Provides a green energy efficient lighting approach to conventional incandescent lighting. Added convenience requires no light bulb replacement.
- **Precision Controlled DC Motor, Complete with Automatic Soft Start and Soft Stop Feature:** The operator automatically detects when your door is almost fully closed or fully opened, and gradually slows the door down before it reaches its fully closed or opened position. During start-up, the door starts moving slowly and gradually ramps up to full speed for the full travel of your door. This reduces the possible damaging effects of the sudden starts and stops associated with some other operators, and results in the smooth operation and increased service life of your door and hardware.
- **Quiet, Smooth Operation:** Precision engineering and carefully selected materials result in extremely smooth and quiet operation, unmatched by conventional garage door operators.
- **Modular Antenna Concept (patented):** Plug-in your choice of frequency module.
- **Built-In Safety Features:** Including patented drive system that delivers only the optimum power needed to move your door safely - Every time!
- **Photo Eye (Infrared) Safety System:** State-of-the-art infrared beam system helps detect obstructions in the path of your door and automatically reverses closing door travel, helping to protect persons and property near the door.
- **LCD Display System Control:** Easy navigation through levels and menus.
- **Convenient Status Display:** To indicate the status of your door operator at any time. Especially useful if troubleshooting is necessary.
- **Numeric Parameter Display Setting:** Provides easier and quicker setup.
- **Numeric Error Code Display:** Provides quicker troubleshooting.
- **Maintenance and Service Scheduling:** Optimizes operator service life and trouble-free performance.
- **The EOS platform unifies all Marantec Products by design.**
- **Meets all UL 325 requirements.**

3. IMPORTANT SAFETY INFORMATION

This manual is essential to the safe and proper installation, operation, and maintenance of your operator. Read and follow all guidelines and operating instructions before the first use of this product. Store the manual in a safe, easily accessible location.



Operate the garage door operator at 120V, 60Hz to avoid operator damage.

Garage doors are heavy, moving objects. When coupled with an automatic operator, electrical power is also present. If not properly installed, balanced, operated, and maintained, an automatic door can become dangerous and cause serious injury or death. Please pay close attention to the WARNING and CAUTION notices that appear throughout this manual. Failure to follow certain instructions may result in damage to the door or door opener, or may result in severe injury or death to yourself or others.

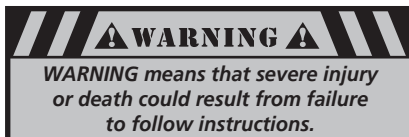

Mechanical

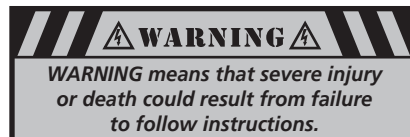

Electrical



4. TOOLS

The instructions will refer to the tools shown below for proper installation, adjustment, and maintenance of the garage door operator. Additional tools may be required depending on your particular installation.

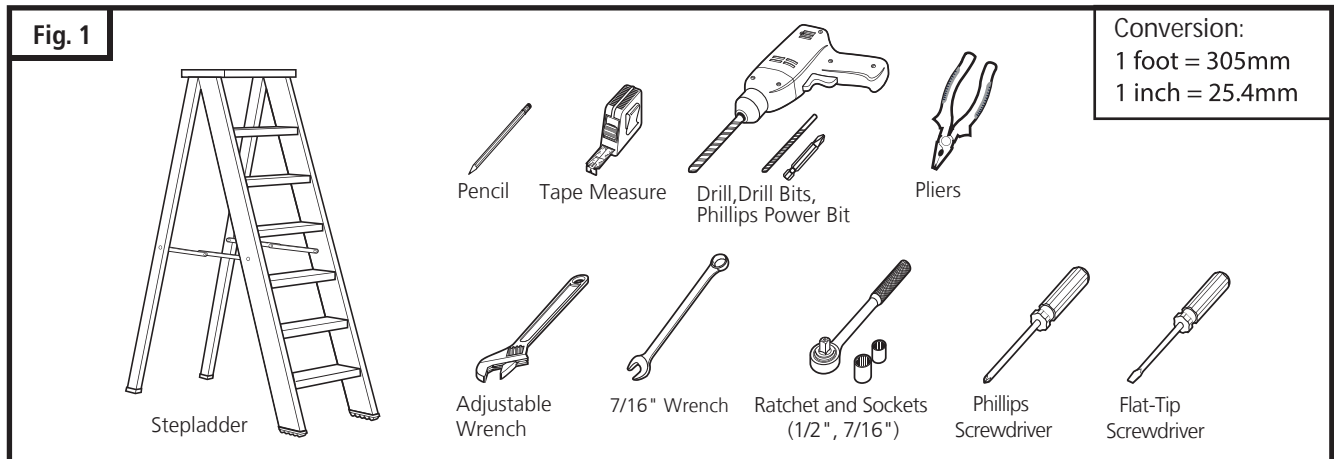

5. GARAGE

WARNING

A garage door is a heavy moving object and can cause serious injury or death. An unbalanced door might not reverse when required, and can increase the risk of injury. If your garage door is out of balance, or if it binds or sticks, call for professional garage door service. Garage doors, springs, pulleys, cables, and hardware are under extreme tension and can cause serious injury or death. Do not try to adjust them yourself. Ropes left on a garage door could cause someone to become entangled and could kill them. Remove all ropes connected to the door before installing your operator.

Take a moment to survey your garage and garage door.

- Is there an access door besides the garage door? If not, you should install an emergency key release kit.
- With the garage door closed, check alignment of door and garage floor. The gap, if any, should be no more than 1/4" (6mm). If the gap is larger than this, repair floor or door before installing operator.
- The operator is intended for installation on a properly balanced and adjusted garage door. **DO NOT INSTALL IF DOOR IS UNBALANCED OR BROKEN.**
- Check balance of door in mid travel and during full range of opening and closing. Lift the door about half way, as shown in Fig. 2 & 3. Release the door. It should remain in place, supported by its springs. Raise and lower the door fully to check for binding or sticking.
- If door is out of balance or needs repair, **DO NOT ADJUST IT YOURSELF. CALL A QUALIFIED GARAGE DOOR SERVICE PROFESSIONAL** to adjust your door.
- If your door is over 7 ft. (2.1m) high, you will need a longer rail. See section 6 "Rail Assembly" on p. 6 of this manual for availability of longer rails.

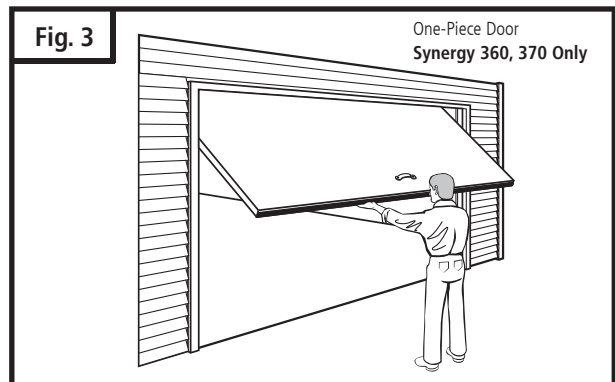
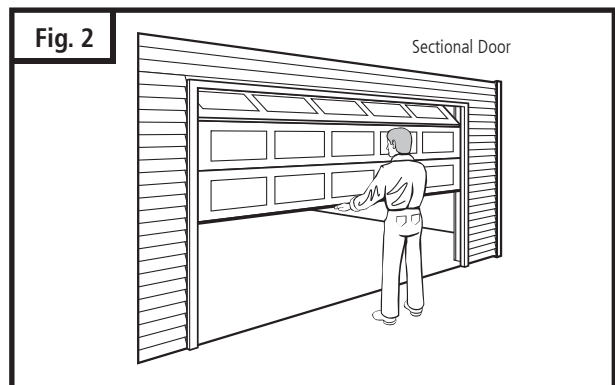

CAUTION

To prevent damage to steel, aluminum, fiberglass or glass panel doors, always reinforce the inside of the door both vertically and horizontally with steel or angle iron bracing.

The best solution is to follow the instructions for your particular garage door or contact the garage door manufacturer for proper reinforcement instructions.

5. GARAGE (cont'd)

Check the type of door construction you have. The information contained in the figures below will be referred to later in the manual for proper installation on the different door types.

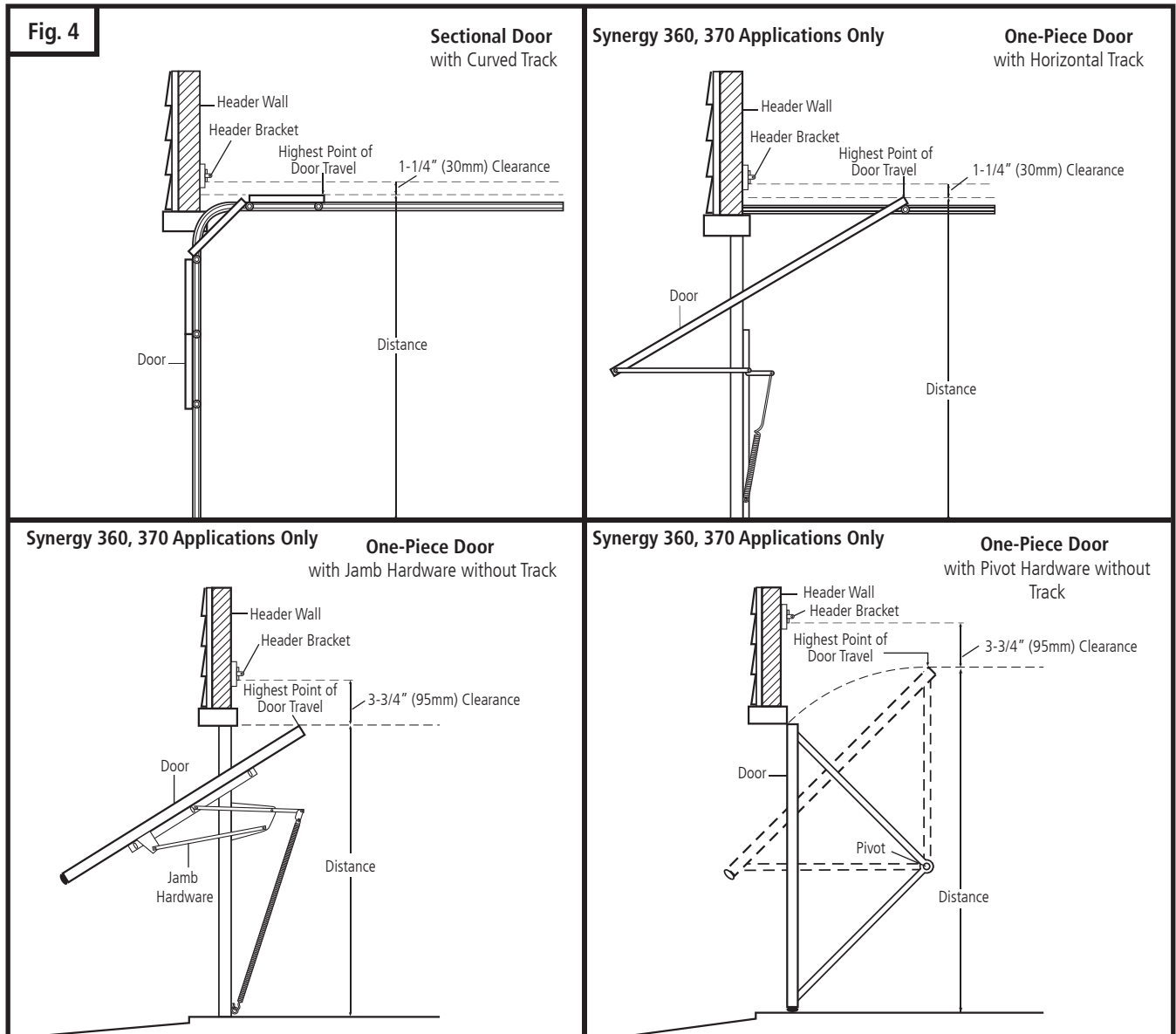

GARAGE DOOR OPERATOR SYSTEM OVERALL DIMENSIONS - 7' (2.1m) DOOR

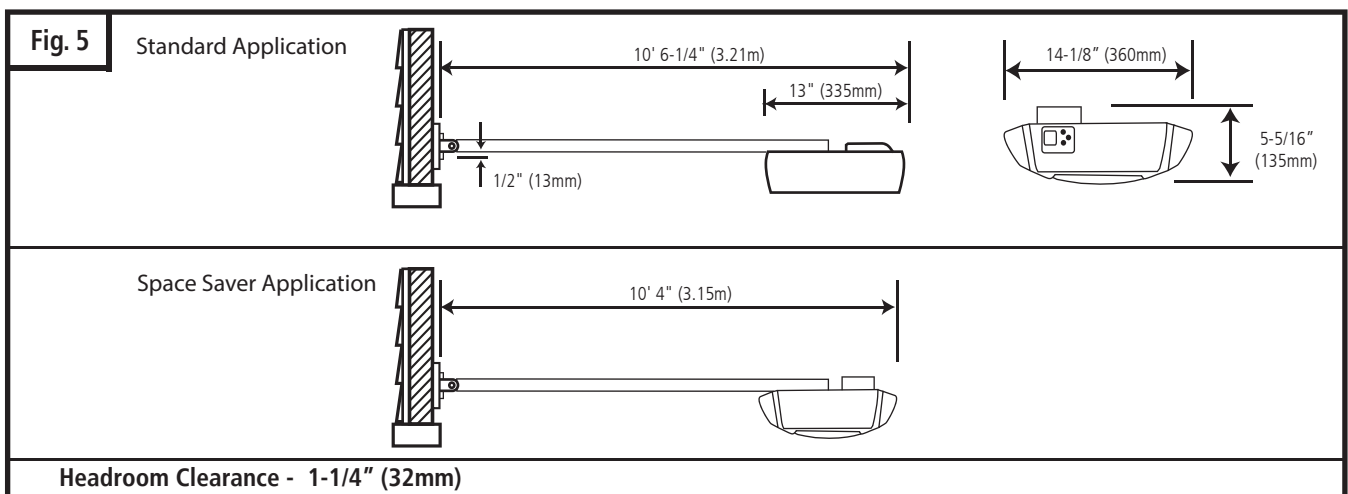

6. OPERATOR PACKAGE CONTENTS

- Remove one of the serial number labels located on both sides of operator carton and apply to the front page of owner's manual. See Fig. 6.
- Remove second serial number label and apply to the warranty card.
- Operator's manufacturing date is located under operator lens cover.

The following items are included with your Garage Door Operator (GDO). All hardware components are located in the GDO carton. The accessories are packaged with their respective hardware in separate packs for ease of identification and use.

Items shown not actual size.

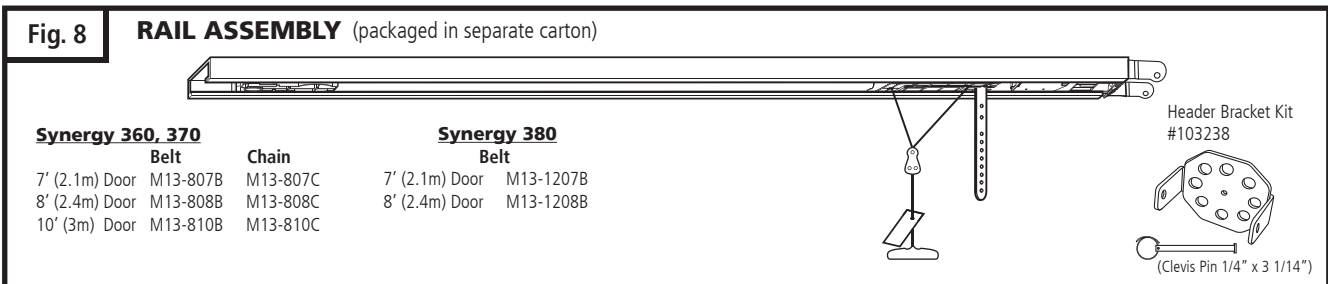
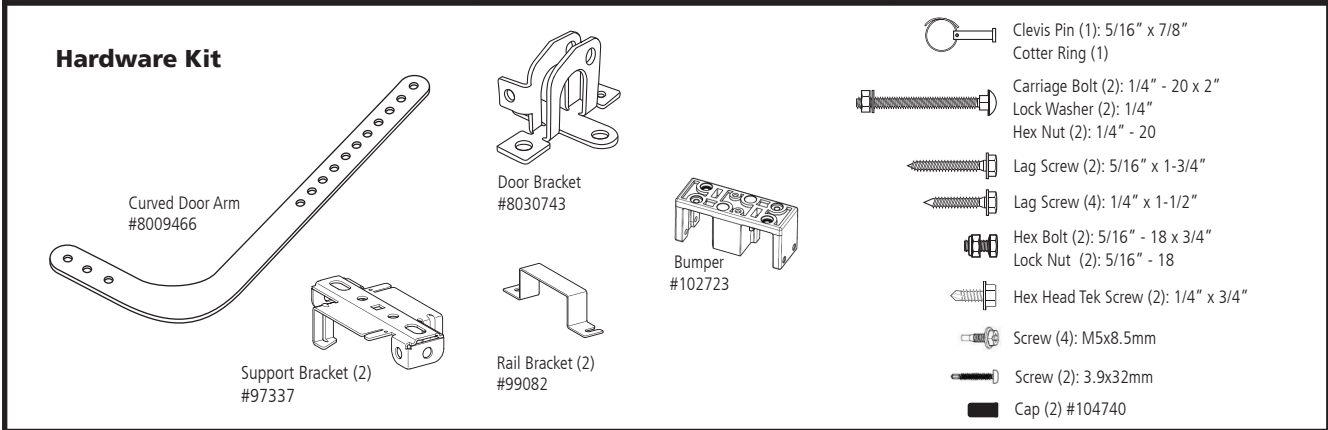
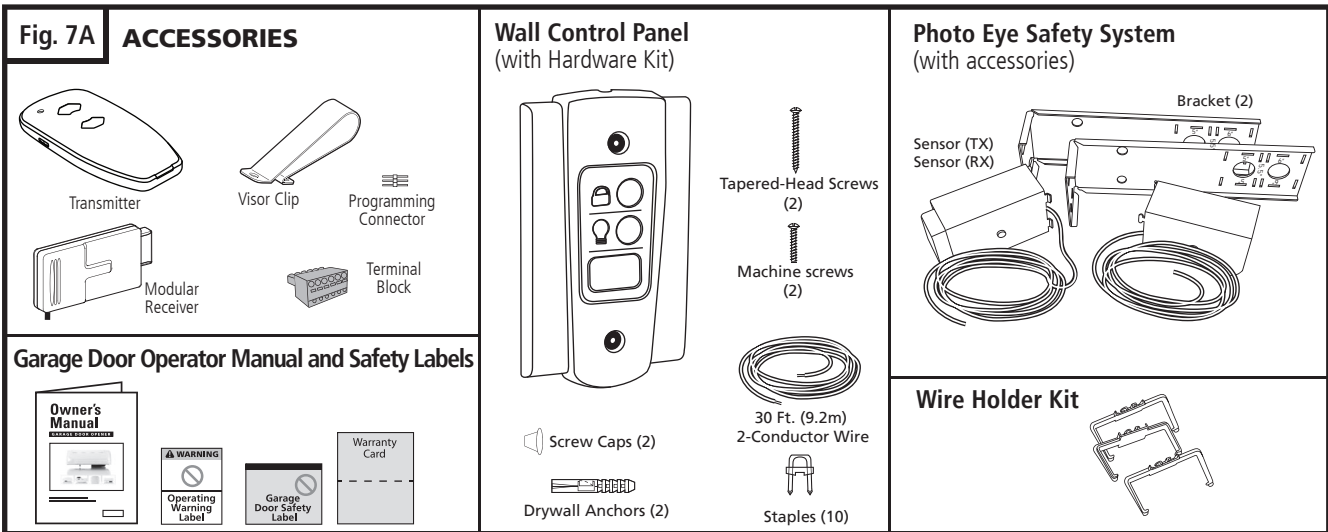
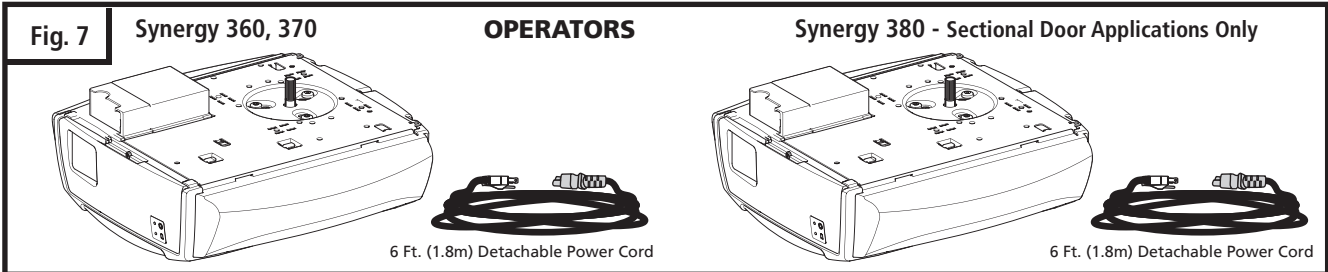
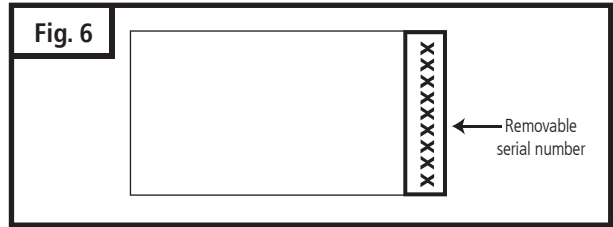
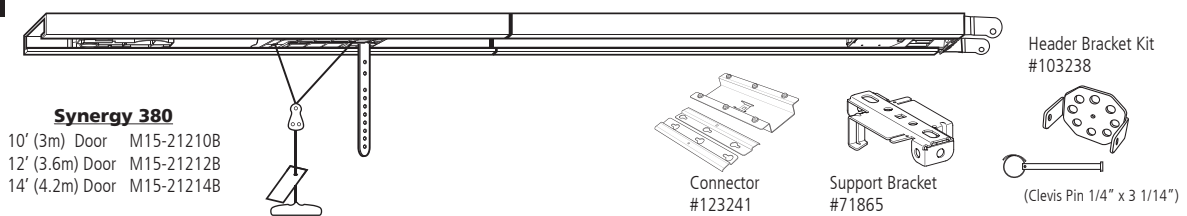

Fig. 8A

2-PIECE BELT RAIL ASSEMBLY (packaged in separate carton)



7. IMPORTANT INSTALLATION INSTRUCTIONS

⚠ WARNING ⚠

TO REDUCE THE RISK OF SEVERE INJURY OR DEATH:

1. READ AND FOLLOW ALL WARNINGS AND INSTALLATION INSTRUCTIONS.
2. **Synergy 380 - Use this operator ONLY with sectional doors.**
3. Check with the door manufacturer to determine if additional reinforcement is required to support the door prior to installation of the door operator.
4. Install operator only on a properly balanced garage door. An improperly balanced door could cause serious injury. Have a qualified service person make repairs to garage door cables, spring assemblies, and other hardware before installing the operator.
5. Remove all ropes and disable all locks connected to the garage door before installing operator.
6. If possible, install the door operator 7 feet (2.1m) or more above the floor. For products having an emergency release, adjust the emergency release cord for the handle to be within reach, but at least 6 feet (1.8m) above the floor and avoiding contact with vehicles to avoid accidental release.
7. Do not connect the operator to source of power until this manual instructs you to do so.
8. Locate the wall control station: (a) within sight of door, (b) at a minimum height of 5 feet (1.5m) above the ground so small children cannot reach it, and (c) away from all moving parts of the door.
9. Place the Operating Warning Label next to the wall control panel in a prominent location. Affix Safety Label on inside of garage door. The Emergency Release markings molded on handle.
10. After installing the operator, test Safety Reversal System. Door **MUST** reverse when it contacts a 1-1/2 inch (40mm) high object (or a 2x4 laid flat) on the floor.
11. **SAVE THESE INSTRUCTIONS** for future safety, adjustment, and maintenance purposes.

For Important Safety Instructions see page 31.

Fig. 9

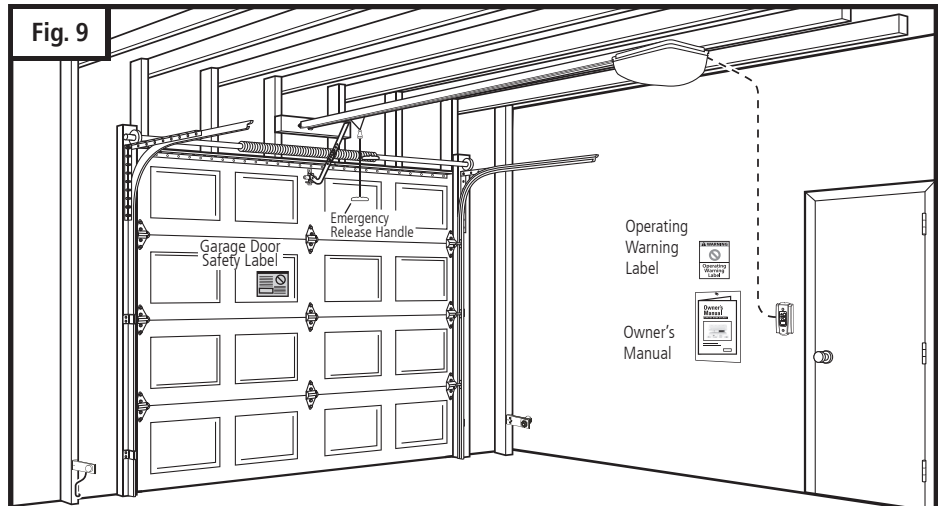

Shown on the right is an overall view of a completed garage door operator system installed on a sectional door. The arrangement is similar for a one-piece door (except for differences described later in this manual).

8. INSTALLATION STEPS

Identify a sound structural support on header wall above garage door for header bracket mounting. See Fig. 10. If appropriate header does not exist, replace or install a new support using a 2x4 (50mm x 100mm) or 2x6 (50mm x 150mm) board. Fasten it securely. See Fig. 11 and 12.

8-1. MEASURE AND MARK DOOR AREA

Before starting your installation, the door and the header above the door must be measured and marked. This way, the appropriate brackets can be mounted at the correct locations avoiding installation and operating difficulties later.

MARK VERTICAL CENTER LINE:

- Measure door width, then locate the center point (Fig. 10).
- Mark a vertical line on the upper half of your door, on the top edge of your door, and on the header, through the center point.

MEASURE DOOR'S HIGHEST TRAVEL POINT:

(Review Fig 4. on p. 7 for details)

- Open door to its highest travel point and measure from the garage floor to the top of door.
- Write down this distance.

FOR SECTIONAL DOORS AND ONE-PIECE DOORS WITH HORIZONTAL TRACK:

Add 1-1/4" (30mm) to the door travel height (measured above).

FOR ONE-PIECE DOORS WITHOUT TRACK:

Add 3-3/4" (95mm) to the door travel height (measured above).

MARK HORIZONTAL LINE FOR HEADER BRACKET LOCATION:

- Close door and measure the required distance (determined above) from the garage floor to the header.
- Mark a horizontal line, intersecting the vertical center line, on header. This is the position at which the bottom of the header bracket should be installed.
- In case of minimal clearance above the door, the header bracket may be mounted to the ceiling. In this case, extend the vertical center line onto the ceiling, and mark a horizontal line on the ceiling no further than 4" (100mm) from the header wall. The header bracket should be mounted no farther than this distance from the header wall.

8-2. INSTALL HEADER BRACKET

Header bracket kit located in rail carton.

⚠ WARNING ⚠

If the header bracket is not rigidly fastened to a sound structural support on the header wall or ceiling, the safety reverse system may not work and could cause serious injury or death. DO NOT move or adjust springs or garage door hardware, as these parts are under extreme tension and could cause injury or death.

Fig. 10

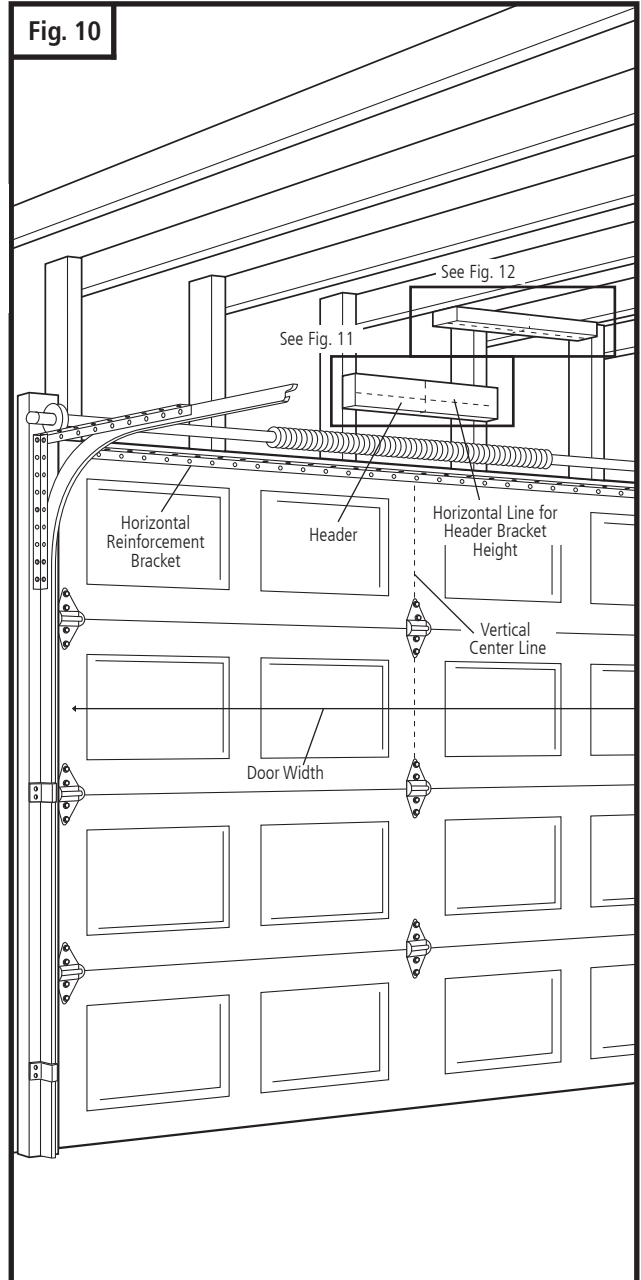
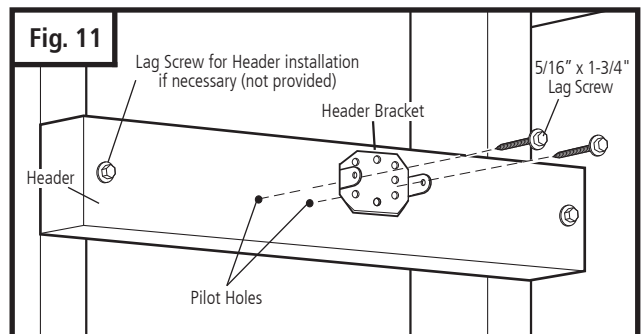

Fig. 11



8-2. INSTALL HEADER BRACKET (cont'd)

- Mark pilot holes location on header through header bracket holes where lag screws will be inserted.
- **IMPORTANT:** See Fig. 11 for which header bracket holes to use.
- Drill 3/16" pilot holes into header, and install bracket with lag screws (5/16" x 1-3/4") provided.
- Tighten lag screws firmly.

NOTE: Follow the same procedure if header runs vertically instead of horizontally and is the only option for mounting header bracket to header wall. In case of minimal clearance above the garage door, the header bracket may be mounted to the ceiling (Fig. 12). Follow the same steps above to ensure a sound surface for mounting.

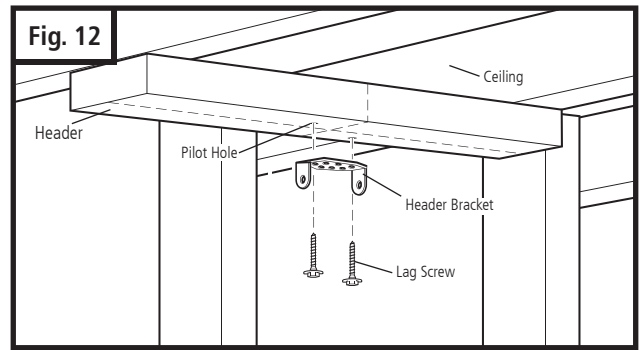

8-3. INSTALL DOOR BRACKET TO DOOR

A. FOR SECTIONAL DOORS:

Wood Sectional Doors (Fig. 13)

- Position door bracket along vertical center line of door with pin hole facing top of the door and top edge of the bracket 4" to 5" (100mm - 125mm) below top edge of the door, or roughly at the same height as top rollers on the door.
- Mark locations of securement holes through door bracket.
- Drill two 1/4" holes through door for securement of door bracket.
- Insert carriage bolts (1/4" x 2") from the outside through door and bracket, then secure with lock washers and nuts from the inside.
- Tighten nuts firmly.

Metal Sectional Doors

- Attach door bracket with two teck screws (provided) per Door manufacturer recommendations.

B. FOR ONE-PIECE DOORS:

Before starting the installation of the door bracket, cut off mounting leg from opposite side of pin hole (Fig. 13).

One-Piece Doors with Exposed Frames (Fig. 14)

- Position center of door bracket on the center line on the top edge of door.
- Mark the position where carriage bolts will go through bracket, and drill two 1/4" holes through top frame of door.
- Install carriage bolts from the bottom, through door frame and bracket, and secure with lock washer and nut from top.
- Tighten nuts firmly.

One-Piece Doors without Exposed Frames (Fig. 15)

- For doors without exposed frames, use alternate method of mounting door bracket.
- Mark and drill two 3/16" pilot holes into top of frame, then secure bracket with 5/16" x 1-5/8" lag screws (not provided).

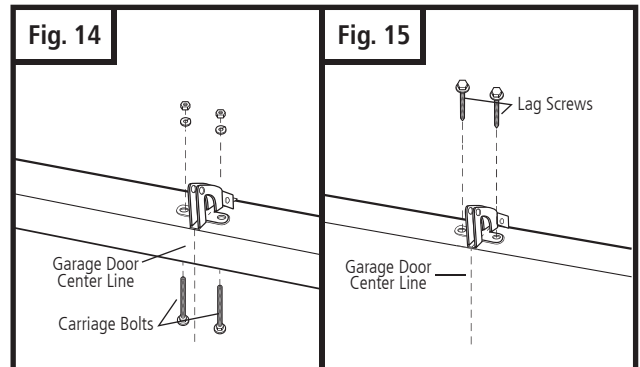
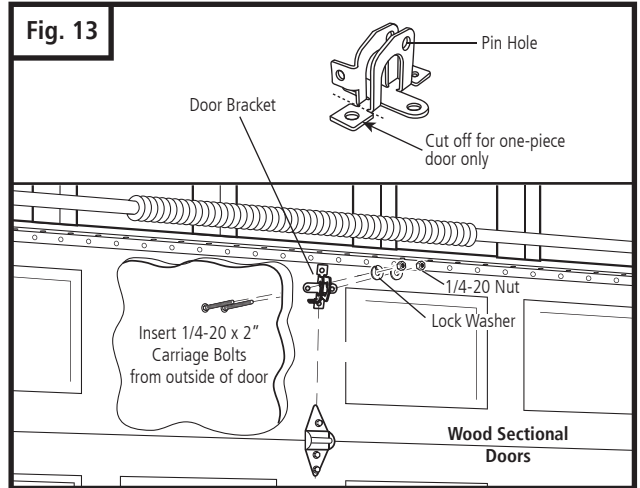

8-4. RAIL ASSEMBLY

NOTE: Rail comes fully preassembled with straight door arm already attached.

- Unpack preassembled rail.
- Leave straight door arm taped inside rail for safe and convenient installation—it will be untaped and used later.
- Place first mounting bracket over rail (close side) on a diagonal. Make sure support securement clamps clear rail sides.
- Twist mounting bracket and secure onto rail 12" (305mm) from sprocket end side of rail as shown in Fig. 16.

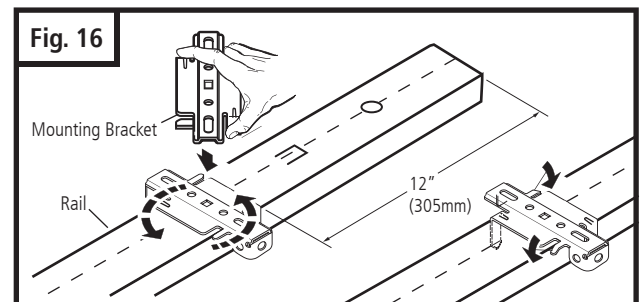

8-4. RAIL ASSEMBLY (cont'd)

- Place second mounting bracket over the backside of the rail 33" (840mm) from pin hole as shown on Fig. 17.
- Secure second bracket. See Fig. 16, pg. 11.

8-5. 2-PIECE RAIL ASSEMBLY

- Unpack 2-piece preassembled and pretensioned rail and place it on the floor.
- Save mounting (center support) bracket for later in the installation.
- Leave straight door arm taped inside rail for safe and convenient installation—it will be untaped and used later.
- Take the rail half with the end bracket and trolley and insert rail in connector as shown in Fig. 18, step 1.
- Swing the other rail half and insert rail in connector as shown in Fig. 18, step 2. Lower the rail end towards the floor to snap rail half in place.
- Install connector clamps and tighten screws as shown in Fig. 19 and 19A.
- Install mounting brackets as described above.
- Place and secure center support bracket as shown in Fig. 20.

Fig. 17

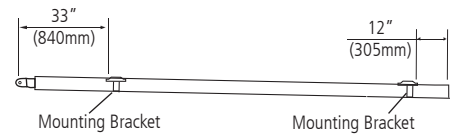

Fig. 18

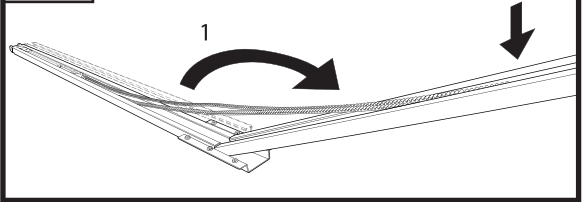

Fig. 19

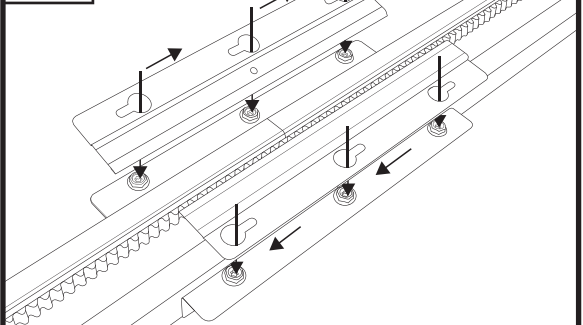

Fig. 19A

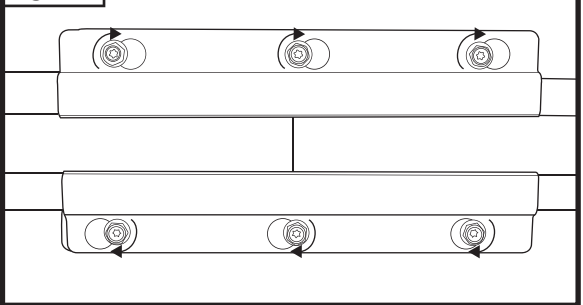
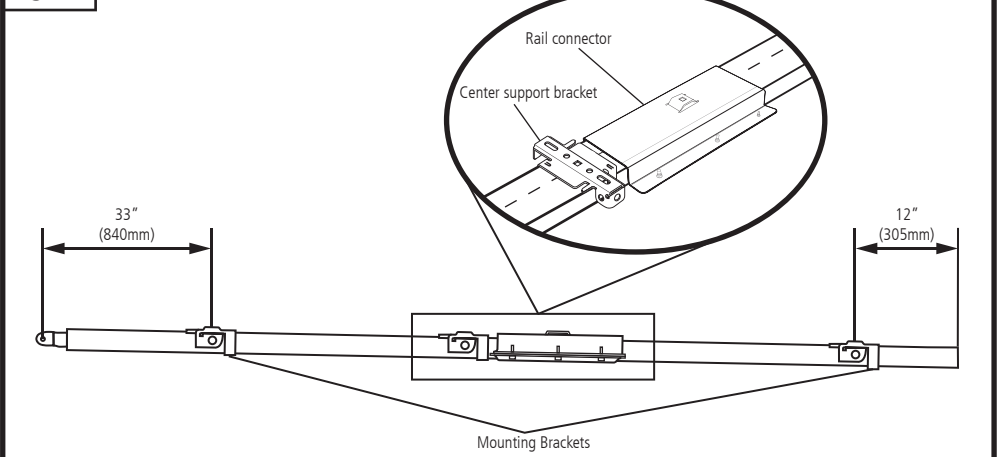

Fig. 20



8-5. 2-PIECE RAIL ASSEMBLY (cont'd)

ADDITIONAL STEP FOR ONE-PIECE DOORS ONLY:

IMPORTANT NOTE: For installation on One-Piece Doors only, the straight door arm that is factory installed onto the rail must be replaced by the curved door arm supplied as part of hardware in the operator box.

Recommended: Replace arm after attaching rail to operator.

- Turn rail over so that open channel in rail faces up.
- Untape straight door arm that is secured inside rail.
- Remove and save the two phillips head screws that are securing the door arm pin and straight door arm (Fig. 21).
- Lift arm and pin straight out of slot in trolley, and remove pin from straight door arm.
- Insert pin into short side of curved door arm as shown.
- Orient arm so that long side extends away from trolley.
- Carefully insert pin and door arm into slot in trolley. Push pin into slot with door arm so pin is fully seated into trolley slot. **IMPORTANT:** Pin must be straight and seated properly into recessed area in trolley. See Fig. 21A.
- Secure pin and curved arm with the two phillips screws which were removed from trolley—DO NOT use any other screws. Tighten screws firmly. See Fig. 21B.

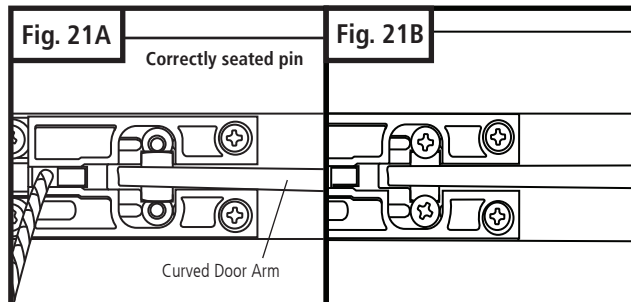
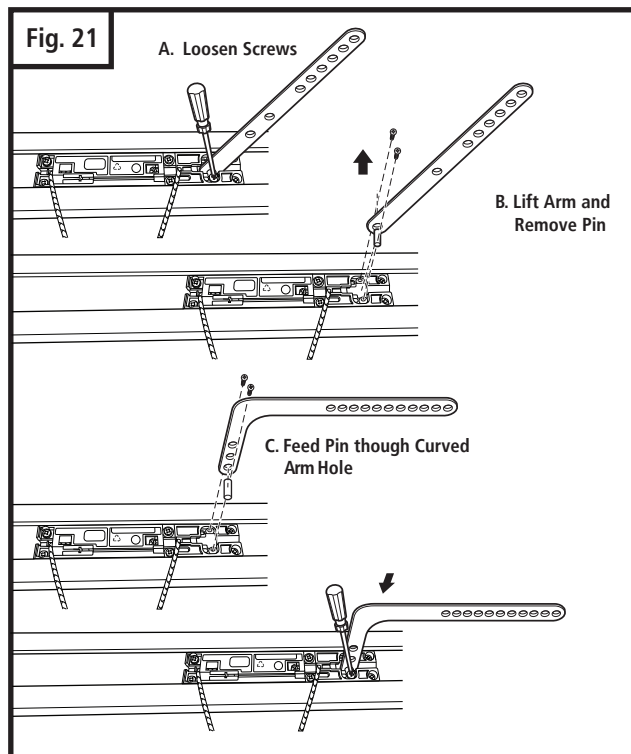

8-6. ATTACH RAIL TO OPERATOR HEAD

⚠ WARNING ⚠

When fastening the rail to the operator, use only the screws provided. Use of any other screws may result in operator falling from ceiling and causing damage to persons or property in the garage.

- Position operator with control panel facing back of garage. Rest operator head on cardboard or protective surface on floor so opener does not get scratched.
- Position rail onto operator chassis by lining up rail sprocket opening with motor head shaft (Fig. 22). Make sure shaft engages teeth inside rail sprocket. Press rail down firmly onto shaft and opener chassis. DO NOT HAMMER.
- Position the two rail brackets over rail as shown in Fig. 22.
- Insert screws (M5 x 8.5) through bracket holes and into chassis holes, and tighten screws firmly to hold rail to head.

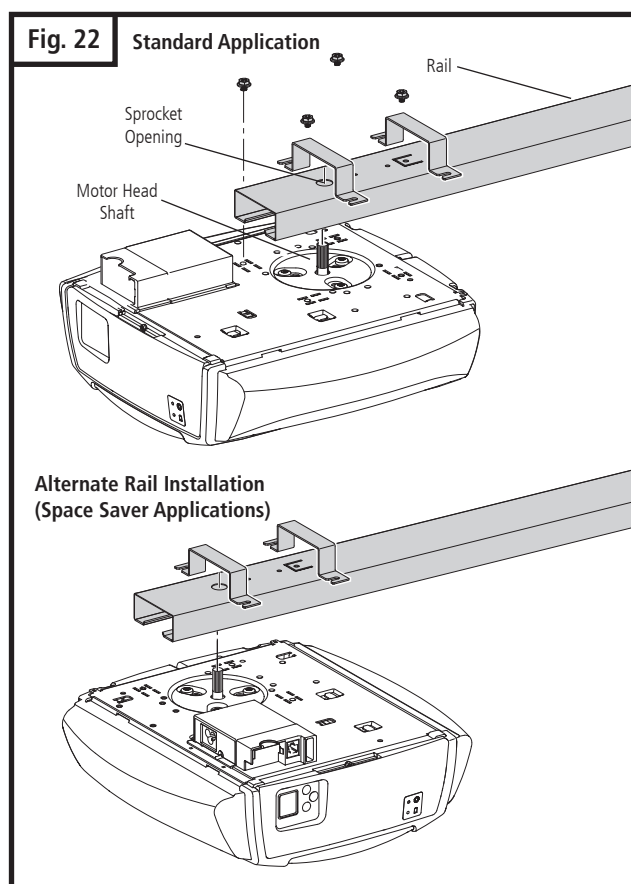

8-7. ATTACH RAIL TO HEADER BRACKET

- Support operator head slightly off the floor.
- Lift the opposite end of the rail up to the header bracket.
- Position rail end-stop within the openings in the header bracket. Insert header clevis pin (1/4" dia.) through header bracket and rail end, then attach cotter ring to end of pin. (See Fig. 23A)

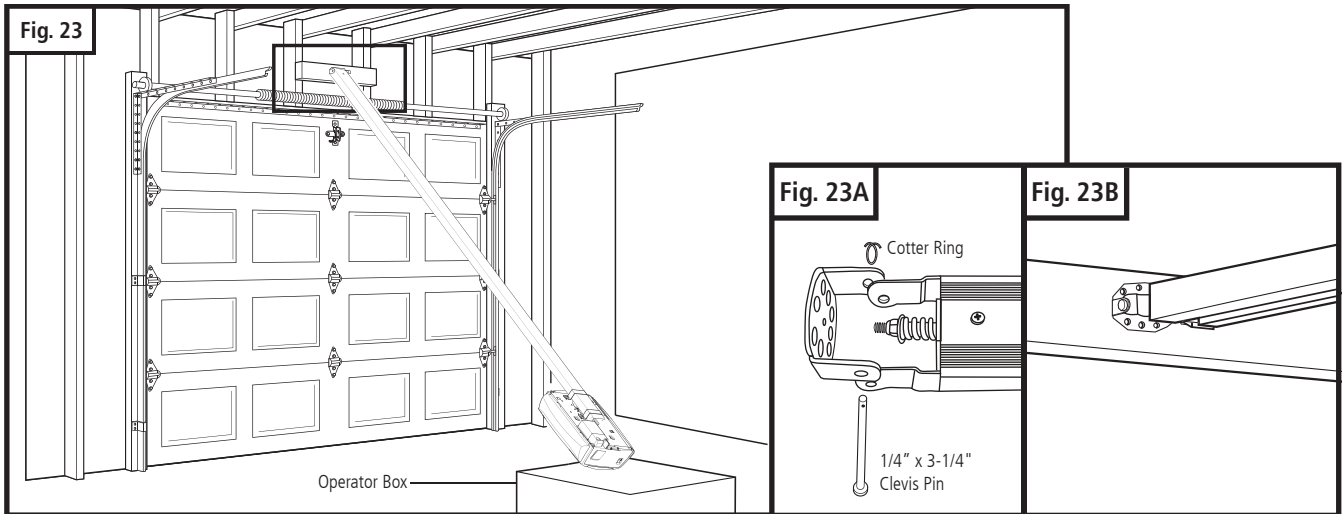

8-8. POSITION OPERATOR FOR MOUNTING

Once rail is attached to header bracket, support operator on ladder, or use the assistance of another person to support operator high enough so door can open without hitting the rail.

⚠ WARNING ⚠

Synergy 380 Install on Sectional Doors ONLY

A. SECTIONAL DOORS AND ONE-PIECE DOORS WITH TRACK:

- Open garage door to fully opened position, and place a 2x4 (50mm x 100mm) laid flat between the door and the rail. See Fig. 24. This provides an easy method of ensuring the correct mounting height of the opener.

B. ONE-PIECE DOORS WITHOUT TRACK:

- Move trolley toward opener head.
- Open door all the way so that it is parallel to the floor, or slightly tilted toward the front of the garage. **DOOR SHOULD NOT BE TILTED TOWARD THE BACK OF GARAGE.**
- Position operator so that top of operator head is level with top of opened door.
- To check for correct mounting height, temporarily position curved door arm as if connecting to door bracket. See Fig. 25. The long side of the arm should be parallel to the floor when door is fully opened. Raise or lower powerhead so that arm will be parallel to floor.
- Temporarily support head at this height, and prepare to mount the operator to ceiling.

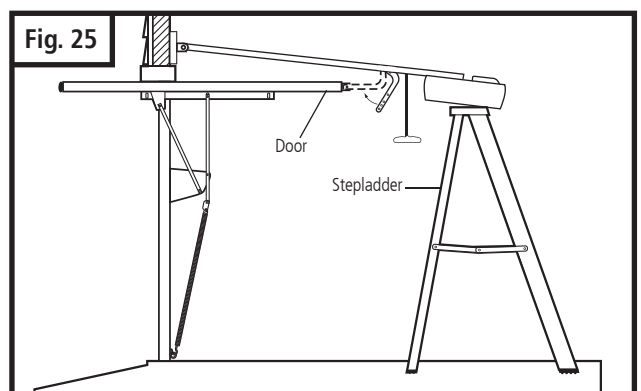
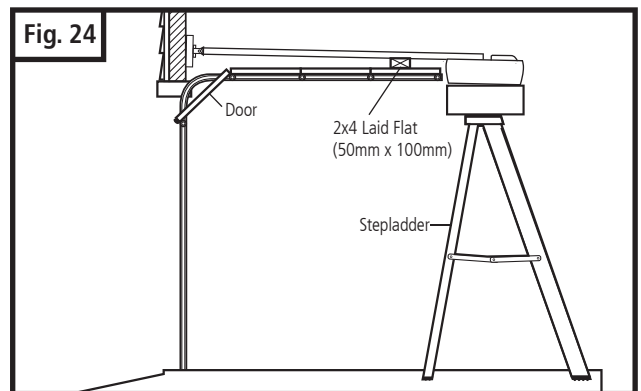

8-9. MOUNT OPERATOR TO CEILING

⚠ WARNING ⚠

If not properly secured, the operator could fall and injure someone. Secure opener to structural supports or framing. Do not mount to drywall, plaster, or other such material.

- Position opener head so that rail is lined up with center line of open door.
- Line up sturdy perforated angle (not provided) with ceiling joists above rail mounting bracket. In case of finished ceiling use stud finder to locate joists.
- Mark location for 5/16" x 2" lag screws (not provided), and drill two 3/16" pilot holes.
- Fasten sturdy perforated angle to joists using lag screws.
- Measure distance from each side of mounting bracket to the perforated angle.
- Cut pieces of hanging brackets (perforated angles) to required lengths.
- Attach one end of each hanging brackets to rail mounting brackets with 5/16"-18 x 7/8" hex bolts, 5/16"-18 nuts, and 5/16" lock washers (hardware not provided).
- Fasten another end of hanging brackets to perforated angles using the same hardware.
- Once opener is securely fastened in position, remove wood block and lower door. Check door for proper operation and clearance by manually moving door to full open and closed position. If door hits rail at any point, raise opener head slightly higher and re-mount in position.
- Mark location and drill pilot holes for second perforated angle which will be located above second mounting bracket.
- Follow the same steps above for second mounting bracket. See Fig. 27.

8-10. CONNECT ARM TO DOOR AND TROLLEY

- Make sure door is fully closed.
 - Remove tape from rail holding straight door arm (sectional door only) and allow door arm to hang freely.
- A. SECTIONAL DOORS:**
- Position curved door arm into door bracket channel so that short end of arm will be attached to door bracket. See Fig. 29. Curved door arm should be attached roughly at the same height as the top rollers of the door.
 - Align curved door arm and bracket holes, then insert clevis pin through holes. Attach cotter ring to hold pin in place.
 - Position straight arm and curved arm to form an angle with the door (Fig. 28) and at least two sets of holes line up. Select two overlapping holes as far apart as possible and secure arms together with hex bolts 5/16"-18 x 3/4" and 5/16"-18 lock nuts
- B. ALL ONE-PIECE DOORS:**
- Curved door arm should already be attached to trolley in place of straight door arm. See Fig. 21 on p. 13.
 - Position free end of curved arm into door bracket slot. Align curved door arm and bracket holes, then insert clevis pin (5/16" dia.) through holes. Attach cotter ring to pin in place. See Fig. 30.
- C. SECTIONAL AND ONE-PIECE DOORS:**
- After connecting appropriate door arm, ensure trolley is disengaged. Check for proper door operation by manually lifting then lowering to fully opened and closed positions.
 - Readjust door arm if needed.

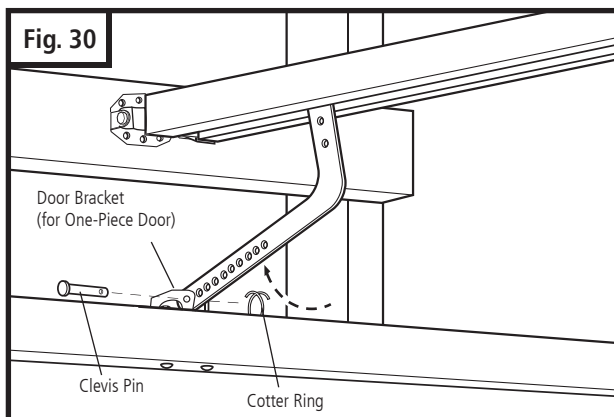
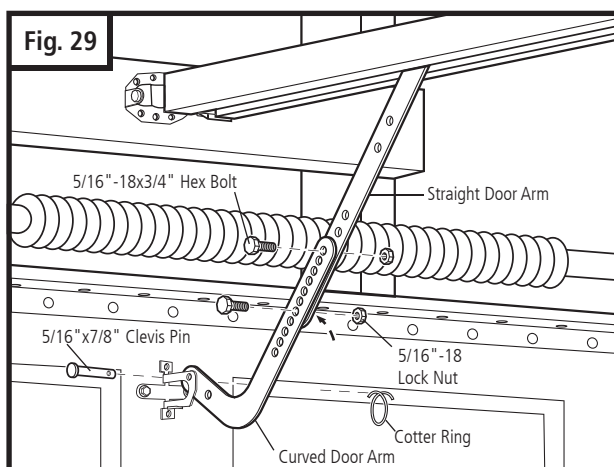
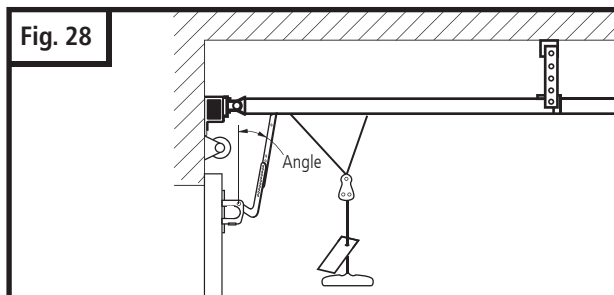
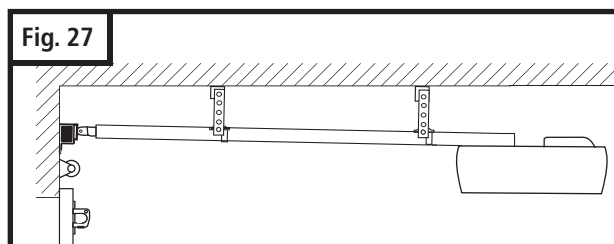
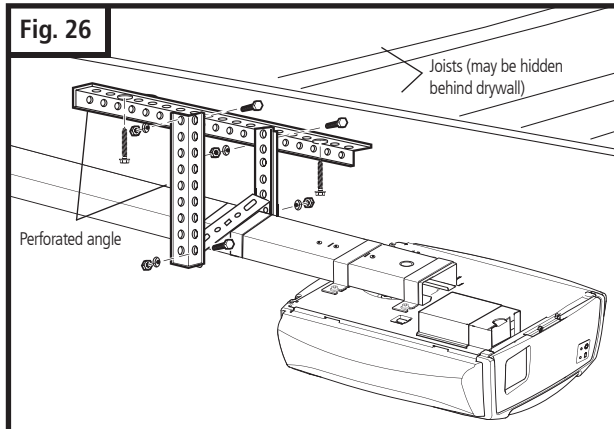

8-11. RAIL BUMPER INSTALLATION

ATTENTION

THE RAIL BUMPER IS AN IMPORTANT PART OF GARAGE DOOR OPERATOR SYSTEM. THE BUMPER IS DESIGNED FOR SETTING UP AND MONITORING THE OPERATOR'S TRAVEL LIMITS.

- With the trolley still in the unlocked position, manually move door up to the desired location. See Fig. 31.
- Snap rail bumper into place as shown in Fig. 32.
- Hold door and measure 1/2" (13mm) between trolley end and the bumper as shown in Fig. 33. This is the installation location for the rail bumper.

Important: The distance between the trolley and the bumper should not be greater than 1/2" (13mm).

- Secure bumper with self-tapped 3.9 x 32mm screws provided. Cover screws with plastic caps provided as shown on Fig. 33.

IMPORTANT NOTE

PULL RELEASE HANDLE TOWARDS DOOR FRAME TO LOCK TROLLEY, THEN MOVE DOOR MANUALLY UNTIL TROLLEY LOCKS WITH CHAIN OR BELT CONNECTOR.

8-12. CHECK EMERGENCY RELEASE

WARNING

To prevent possible **SERIOUS INJURY** or **DEATH** from a falling garage door:

- If possible, use emergency release handle to disengage trolley **ONLY** when garage door is **CLOSED**. Weak or broken springs or unbalanced door could result in an open door falling rapidly and/or unexpectedly.
- **NEVER** use emergency release handle unless garage doorway is clear of persons and obstructions.
- **NEVER** use handle to pull door open or closed.

The release cord with handle should be adjusted to hang 6 ft. (1.8m) above garage floor.

To adjust:

- Slide handle up on cord.
- Tie new knot at correct height.
- Cut excess cord, leaving approximately 1" (25mm) after knot.
- Heatseal end of cord with match or lighter to prevent fraying.
- Slide handle back into place.

The emergency release cord with red handle which is already attached to the trolley, are extremely important parts of the operator system. Pulling the release cord see Fig. 34 disengages the door from the opener. This allows the door to be moved manually up and down independent of the opener motor.

If the door is in the open position, use extreme care when using the release.

Use emergency release to disconnect the door if the power is out. This allows the door to be moved manually up and down independent of the operator motor. It should also be used if for some unforeseen reason the door strikes a person or object during its travel and does not automatically reverse off the obstruction.

To release door—pull emergency release handle toward the operator at approximately 45 degrees. (Fig. 34)

Prior to re-engaging door, ensure that all obstructions are removed and door is operating properly manually. Before re-engaging trolley with a belt connector, pull handle toward the door at approximately a 45 degree angle. Now the door can be reconnected by moving it manually and bringing it into position when the connector is inside of the trolley.

Fig. 31

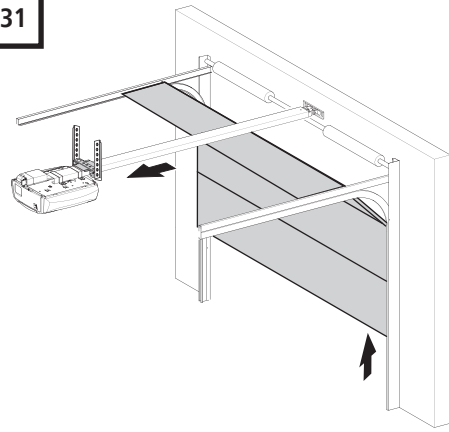

Fig. 32

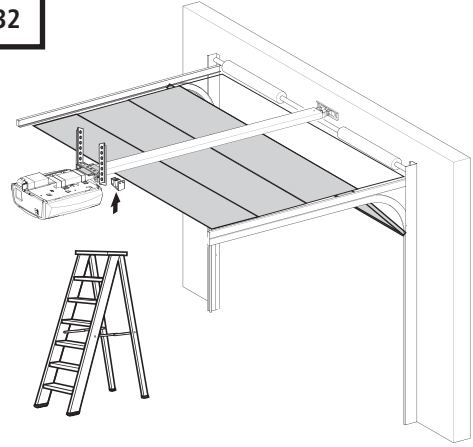

Fig. 33

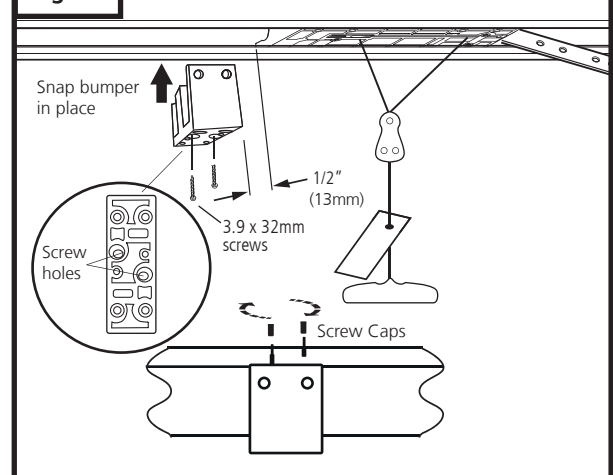
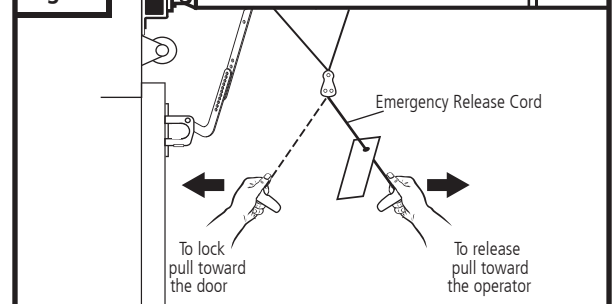

Fig. 34



8-13. INSTALL PHOTO EYE SAFETY SYSTEM

WARNING

To provide the maximum protection install the photo eye sensors so beam is NO HIGHER than 6" (150mm).

MOUNTING THE PHOTO EYE SENSOR BRACKETS TO WALL:

- Locate the mounting position for photo eye brackets 3.5" to 5" (90-125mm) from floor level. After mounting, the photo eye beam must have a clear path from one side of the door to the other.
- Use the bracket mounting holes as a template to locate an drill (2) 3/16" diameter pilot holes on both sides of the garage door as shown in Fig. 35.
- Secure the bracket with 1/4" x 1-1/2" lag screws provided as shown in Fig. 35.

Note: If needed use extension brackets (see accessories page 35).

MOUNTING THE PHOTO EYE SENSORS TO MOUNTING BRACKET. Fig. 37

- Install the sensors to the mounting bracket by inserting bend clips of sensor bracket through the vertical slot on mounting bracket.
- Insert straight clips through other set of vertical slot on the mounting bracket.
- Twist one of the straight clips slightly to lock the sensor in place once inserted through vertical slot on the mounting bracket.
- Repeat the above procedure for the other sensor.

ROUTE WIRES Fig. 38

- Route wires along wall use staples (not provided) to secure wiring to wall. Do NOT punch wire. Drive staples with only enough force to hold wiring in place. Be sure the wiring is routed away from all moving parts of door and rail.
- Run wires along the top of the rail assembly and secure them in wire holders.

DUAL DOOR INSTALLATION Fig. 39

- In dual door installations, the transmitter (TX) and the receiver (RX) photo eye sensors (as marked on each of the photo eye components) should be mounted as indicated. TX and RX marks are located on the back side of the transmitter and receiver.

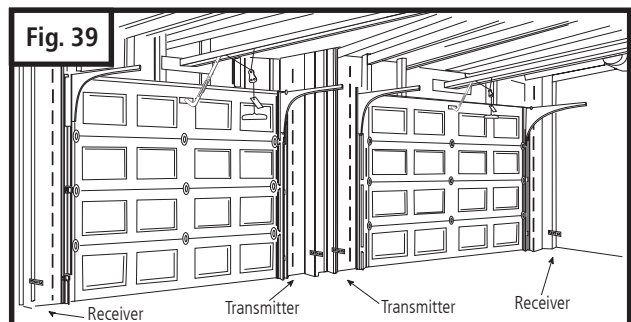
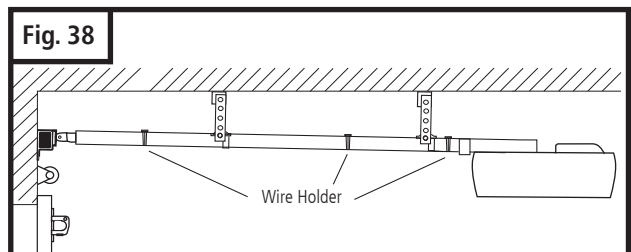
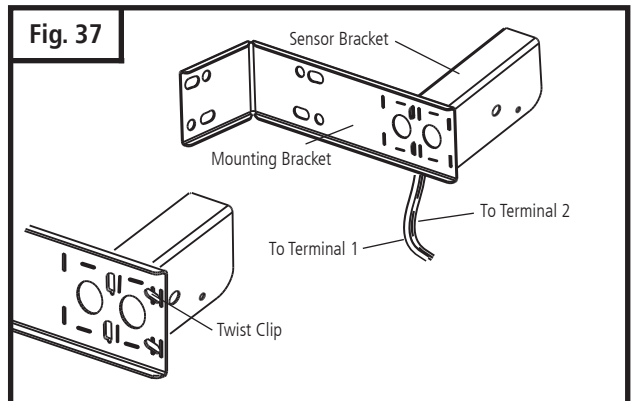
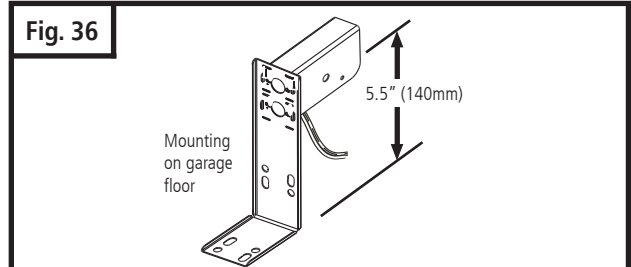
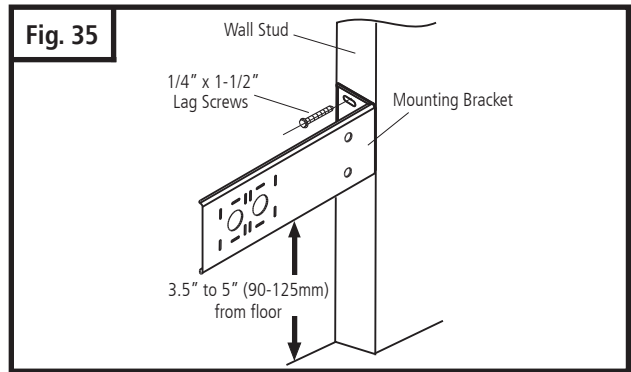

8-14. INSTALL WALL CONTROL PANEL

The control panel must be mounted inside the garage within sight of the garage door, clear of all moving garage door parts or any associated parts - and at least 5 feet (1.5m) above the floor to prevent the use of these controls by children. The device should only be used when the door is in clear sight of the user and the door area is free of people or any obstructions.

- Attach 2-conductor wire to the screw terminal on back of control panel. See Fig. 40 (Back). White wire attaches to terminal #3 screw, white wire with color stripes attaches to terminal #4 screw.
- Position wall control panel onto wall in desired location.
- Mark hole location on wall.
- Drill 1/16" pilot holes into wall.
- Insert and tighten screws to secure control panel to wall.
- Make sure wiring is routed out from behind control through one of the cutouts to avoid pinching the wires.
- Route wires along wall use staples (provided) to secure wiring to wall. Do NOT punch wire. Drive staples with only enough force to hold wiring in place.

If mounting to drywall instead of wood, drill 3/16" pilot holes and use anchors provided. If mounting to electrical box that is prewired for this purpose, mount directly to box with proper screws provided. See Fig. 40A.

Multiple Wall Control (Fig. 40B):

- Wall control design provides a modular assembly of multiple wall controls.
- **Each wall control must be connected to a designated garage door opener, only one wall control per operator.**
- Detach wall control's right side panel(s).
- Attach wiring to back on each wall control (white wires to terminal #3 screws, wires with stripes to terminal #4 screws).
- Assemble wall control module and secure to the wall.
- Complete installation as outlined above in step 1 and 2 for each wall control.

8-15. CONNECTING WIRES TO OPERATOR

- Separate the double wire from each photo eye into two single wires: the white wire and the white wire with black stripes.
- Combine the white wires from each photo eye and twist stripped ends together tightly.
- Insert stripped end of white wire combination into terminal block hole #1.
- Repeat procedure for the white wires with black stripes except insert them into terminal hole #2.
- Separate the double wire from wall control into two single wires: the white wire and the white wire with red stripes.
- Insert stripped end of white wire into terminal block hole #3.
- Insert stripped end of white wire with red stripes into terminal block hole #4.
- Connect terminal block with attached wires to control unit, see Fig. 41, 44.

For reference see wiring diagram Fig. 45

Fig. 40

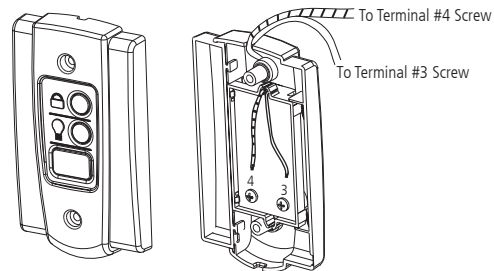

Fig. 40A

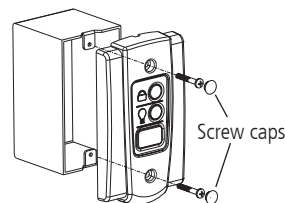

Fig. 40B

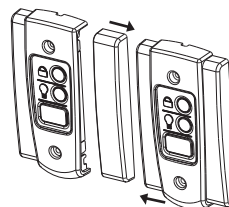
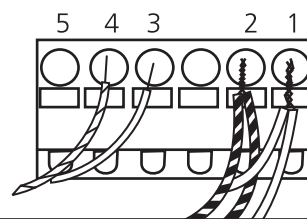

Fig. 41



9. CONTROL UNIT CONNECTIONS



WARNING

Danger of electric shock:

Before any wiring work begin, make sure that the operator and all wiring is disconnected from the power supply. During wiring make sure all wires remain disconnected from the power supply at all times.

A	GDO expansion module slot
B	Integrable Battery backup (optional)
C	Battery backup display
XB03	Connection for – Wall control – Photo eye safety system
XB72	Connection for modular antenna
XN70	Connection for battery backup
XW40	Connection for MS bus expansion module
XW81	Inputs/outputs modules connection

Fig. 42

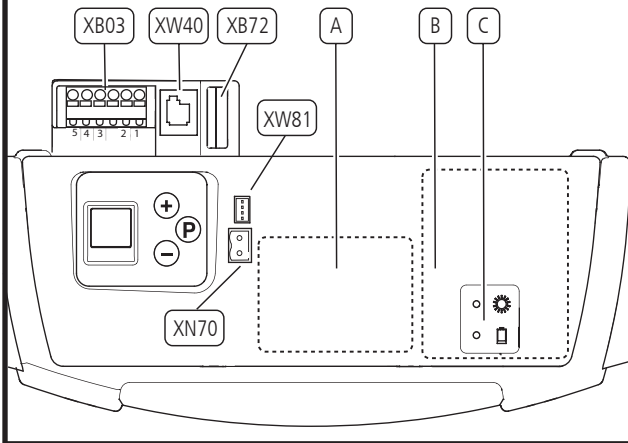

Fig. 43 Modular Antenna Installation or Replacement

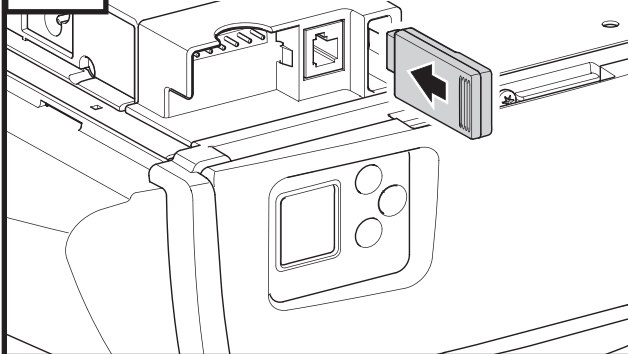

Fig. 44 Terminal block XB03

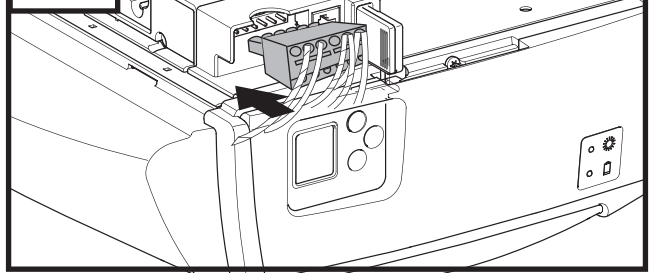
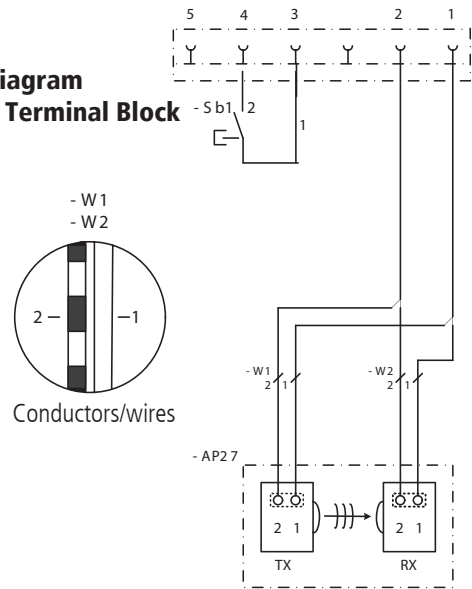

Fig. 45

Wiring Diagram for XB03 Terminal Block



AP27	Photo eye safety system
RX	Photo eye receiver
TX	Photo eye transmitter
1	Photo eye - Conductor 1
2	Photo eye - Conductor 2
Sb1	Impulse button - Wall Control
3	Wall control - Impulse - Conductor 1
4	Wall control - GROUND - Conductor 2
5	24 V DC

10. CONNECT TO POWER

To reduce the risk of electric shock, your operator is provided with an insulated power cord with a 3-prong grounding plug. The cord must be connected to a standard grounding outlet. If there is no outlet available at the location, you must have a qualified electrician install an approved grounded outlet in this area.

⚠ WARNING ⚠

To prevent electrocution or fire, installation and wiring must be done in accordance with local electrical and building codes. DO NOT use an extension cord. DO NOT use a 3 to 2 plug adapter. DO NOT modify or cut off the grounding pin on the plug.

- Plug the operator into a properly grounded outlet (Fig. 46).
- The display will illuminate the word "On" and  will be displayed. This indicates that the operator is ready for set up. See Fig. 47B for additional display icons.
- DO NOT operate or run the opener at this time.

Fig. 46



IMPORTANT:

Contact Marantec America for Replacement Power Cord

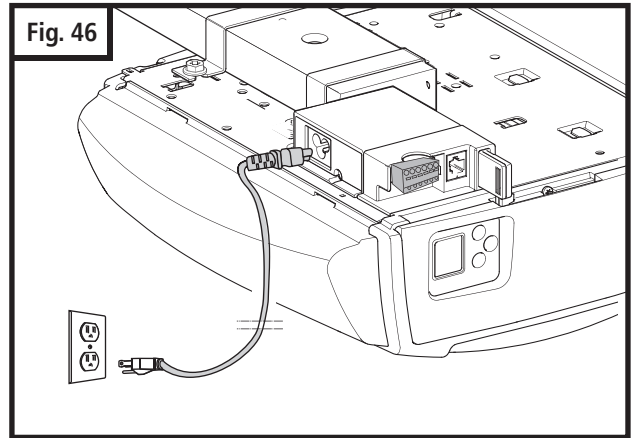
Part #105475
 Model: YP-12/YC-12
 Overall length 6ft.
 UL/CSA Recognized
 UL Type: E241374: SJT 3/C 18AWG 105°C 300V VW-1
 CSA 177323: SJT 3/C 18AWG 105°C 300V FT2

11. SYSTEM SET UP

⚠ WARNING ⚠

In order to insure a trouble-free programming:

- **The door must be in the "CLOSED" position and engaged to the drive system (rail) before programming the operator or a system reset is performed.**

Fig. 47

Overview of the control unit

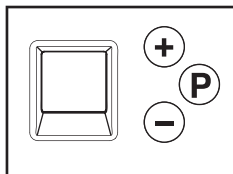

Control elements



LED display



-  Drive the door in the OPEN direction, increase the value
-  Drive the door in the CLOSE direction, decrease the value
-  Start programming, confirm and save values

Fig. 47A



Press and hold at the same time all three control buttons, (+, -, P) as shown until counter reaches 20. Then depress buttons and let system reset.

Once the operator completes the Reset Process, The LCD display illuminates and stand-by mode is displayed as shown.

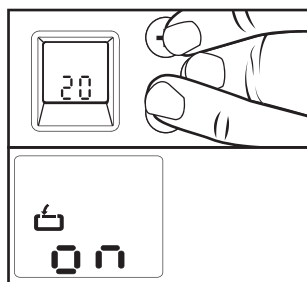
For proper initial operation of the operator, three basic functions must be set using the initial system programming:

- Open Door Position
- Close Door Position
- Program Remote Control (Transmitter)

Press and hold the "P" button for approximately 3 seconds. When  illuminates, release the button. You are now ready to set or change the desired adjustment. If no buttons are pressed within 120 seconds while in programming mode, the control unit reverts back to operating mode.

TO MAKE OR CHANGE ANY ADJUSTMENT

If no changes are needed at any particular stage, you can keep the current information and "skip" over a specific adjustment by pressing the "P" button once. This is useful to know if you want to change only one setting, without changing any of the other adjustments. Simply enter the adjustment mode by pressing and holding the "P" button for approximately 2 seconds, then press and release "P" repeatedly until your particular adjustment is reached. This bypasses the unneeded adjustments, and takes you right to the adjustment you want. When your adjustment or setting is complete, simply press "P" as many times as needed to bypass the remaining steps and exit out of the program, returning the operator to normal mode.

NOTE: You may exit the System Set Up at any time by pressing the button "P" for more than 5 sec. The set up programming can be terminated at any time and from any stage. To do so, press the "P" button for longer than 5 seconds.

RESET FUNCTION

There might be times when the operator may have to reset in order to restore the operating system factory default setting. To reset operator by using three control buttons, (+, -, P) see Fig. 47A or use operator reset procedure on page 23.

11. SYSTEM SET UP (cont'd)

Fig. 47B

Display	Description	Display	Description
	Ready for operation		Level indicator Display shows Level 2
	Door position: CLOSED		Menu and parameter indicator (Displayed Menu 3, Parameter Setting 8)
	Door position: OPEN	Minute indicator	
	Fault message / Maintenance indicator in CLOSED door position		Times exceeding one minute are shown in minutes and seconds. Example: 1.2 = 1 minute + 20 seconds = 80 seconds
	Photoeye safety system	Status display	
	Remote control	Display	Function / Element
	External button		Warning time indicator (only for programmed automatic closing)
	Status display Battery backup system connected		

<p>System initial display on control panel screen upon power ON</p>	<p>1 System set up start and program open door travel position</p> <ul style="list-style-type: none"> To start the system set up, press and hold the button for approximately 5 seconds. Once the display timer counter reaches the count of 5, release the button. The blinking open door icon is displayed on the control panel screen. Set the open door travel position by pressing and holding the button until the door reaches the desired open travel position. Further fine tuning of the open position can be performed by using the or buttons. Important Note: The back of the trolley must be approximately half inch from the reference bumper on rail. Once the desired open travel position is reached, press button to save open travel position and move to the next step in the system set up. 	<p>Control Panel Display</p>	<p>System display on control panel screen after set-up is completed.</p>
	<p>2 Program close door travel position</p> <ul style="list-style-type: none"> The blinking closed door icon is displayed on the control panel screen. Set the close door travel position by pressing and holding the button until the door reaches the down travel position desired. Important Note: In order to avoid unintentional door reversal, DO NOT set the down travel position too close to the floor where the door rubber seal is completely squeezed/compressed against the ground. Further fine tuning of the close travel position can be performed by using the or buttons. Once the desired close travel position is reached press button to save the close travel position and move to the next step in the system set up. 		
	<p>3 Program a remote control (transmitter)</p> <ul style="list-style-type: none"> The transmission icon will blink on the control panel display. This indicates the operator is ready to learn the remote control code. Press and hold the button on the remote control that you wish to use. The transmission icon will change its displayed symbol to a solid icon. This indicates that the remote control code has been successfully learned by operator. Release the remote control button. Press button to save remote control code and end the system set up. 		

11. SYSTEM SET UP (cont'd)

NORMAL OPERATION IMPORTANT:

On the first open travel activation, the trolley will make contact with and will rest against the rail bumper. This will appear as if the system (door) went past the set open travel limit. However, this is not the case. On the next open travel cycle, the system will recognize the program travel limit. Every 20 cycles the operator will perform a travel limit check and it will function as described on "Normal Operation" note.

IMPORTANT:

Upon completion of the initial set up, the operator must be cycled for two complete cycles (complete cycle comprises of one uninterrupted up activation of the system and one uninterrupted down activation of the system).

Legend:

Drive the door in the OPEN direction, increase the value	
Drive the door in the CLOSE direction, decrease the value	
Start programming, confirm and save values	
The display flashes	
Display lights up	
Ready for operation	
Door position: CLOSED	
Door position: OPEN	
Fault message/Maintenance indicator in CLOSED door position	
Photoeye safety system or closing edge safety device	
Remote control	
External button	

12. ADVANCED SETTINGS

CAUTION

Additional operator functions can be set using the advanced operator functions. Parameters factory default settings can be restored. This programming may only be carried out by a professional installer.

CAUTION

After a system reset, all parameters are restored to the factory settings.

- All the required function in the initial set up and advanced settings must be re-programmed if it is required.
- The operator must be activated for two (2) complete uninterrupted cycles in order for all restored or operating parameters settings to be learned by the operator again.

Advanced Settings Programming Procedure (Diagram Illustrates Setting of Level 6, Menu 4)

1.	Door should be in closed position. The control system operating mode will be displayed as shown.		7.	Press and release to change screen display. Number "7" will blink.	
2.	Press and hold until counter passes number "10". Then release the button. Screen display as shown.		8.	Press and release . Save parameter setting.	
3.	Press to select Level 6. Screen display as shown.		9.	Press for 5 seconds to exit advanced settings set up.	
4.	Press . Menu 1 will appear on display as shown.		OR		
5.	Press to select Menu 4 (reset menu). Screen will display "16" as shown.		10.	Repeat steps 2-8 to change other Menu parameters	
6.	Press and release . Number "16" blinks.		Note: Level 3 is disable		

12. ADVANCED SETTINGS (cont'd)

General overview of the programmable functions

Level	Menu	Factory default setting
Level 1 – Basic function	Menu 3: Intermediate "OPEN Position"	
	Menu 8: RESET	
Level 2 – Operator settings	Menu 1: "OPEN" position – operator (system) force	Setting 8
	Menu 2: "CLOSE" position – operator (system) force	Setting 8
	Menu 3: "OPEN" position – operator sensitivity	Setting 10
	Menu 4: "CLOSE" position – operator sensitivity	Setting 10
Level 4 – Transmitter Additional Functions	Menu 2: "Intermediate "OPEN Position"	
Level 5	Menu 4: Light timer	Setting 4.1 (255 sec)
Level 6 – Variable speed	Menu 1: OPEN speed	Setting 12
	Menu 2: Soft run OPEN speed	Setting 7
	Menu 3: Soft run OPEN position	
	Menu 4: CLOSE speed	Setting 12
	Menu 6: Soft run CLOSE speed	Setting 7
	Menu 8: Soft run CLOSE position	
Level 7 – Maintenance and servicing	Menu 1: Door cycle counter	
	Menu 2: Servicing counter	
	Menu 3: Servicing interval	
	Menu 8: Reset maintenance and servicing	
	Menu 9: Fault indicator	
Level 8	Menu 7: Force relief CLOSED door position	Setting 1 - Not Active







Level 1: Basic Functions

Menu 3: Intermediate OPEN Position

Set using the (+ / OPEN) and (- / CLOSE) buttons
The closing function with automatic closing is possible. Only the intermediate position that was programmed last can be used.

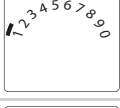
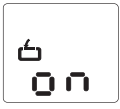
Menu 8: System RESET

1	No reset
2	Reset system settings

Reset Procedure					
1.	Door should be in closed position. The control system operating mode will be displayed as shown.		7.	Press and release ⊕ to change screen display. Number "2" will blink.	
2.	Press and hold ⊕ button until counter passes number "10". Then release the ⊕ button. Screen display as shown.		8.	Press and release ⊕ to reset operator. During reset the display screen will turn blank for a couple of seconds.	
3.	Press ⊖ to select Level 1. Screen display as shown.		9.	Upon completion of operator reset, the LCD display illuminates. Stand-by mode is displayed as shown.	
4.	Press ⊕. Menu 3 will appear on display as shown.		10.	<p>The operator must be set up again as described in Section 11.</p> <p>IMPORTANT: Upon completion of the initial set up, the operator must be cycled for two complete cycles (complete cycle comprises of one uninterrupted up activation of the system and one uninterrupted down activation of the system).</p>	
5.	Press ⊕ to select Menu 8 (reset menu). Screen will display "1" as shown.				
6.	Press and release ⊕. Number "1" blinks.				

12. ADVANCED SETTINGS (cont'd)

Level 2: Operator settings

Menu 1: "OPEN" position operator (system) operating force														← Lower Force		Higher Force →	
8	1	2	3	4	5	6	7	8	9	10	11	12	13				
Menu 2: "CLOSE" position operator (system) operating force														← Lower Force		Higher Force →	
8	1	2	3	4	5	6	7	8	9	10	11	12	13				
Menu 3: "OPEN" position operator sensitivity														← More Sensitive		Less sensitive →	
10	OFF	2	3	4	5	6	7	8	9	10	11	12	13				
Menu 4: "CLOSE" position operator sensitivity														← More Sensitive		Less sensitive →	
10	OFF	2	3	4	5	6	7	8	9	10	11	12	13				

Level 4: Transmitter Additional Functions

Menu 2: Intermediate OPEN Position													
Set using the (+ / OPEN) and (- / CLOSE) buttons The closing function with automatic closing is possible. Only the intermediate position that was programmed last can be used.													

Level 5: Functions overview

Menu 4: Operator Light "ON" →																
Timer (in seconds)										Timer (in minutes)						
	2	5	10	15	20	25	30	35	40	50	1.2 (80sec)	1.4 (100sec)	2.0 (120sec)	2.3 (150sec)	3.0 (180sec)	4.1 (255sec)

Level 6: Variable Speed

Menu 1: OPEN speed														← Slower		Faster →				
12	-	-	-	-	5	6	7	8	9	10	11	12	13	14	15	16				
Menu 2: Soft run OPEN speed														← Slower		Faster →				
7	1	2	3	4	5	6	7	-	-	-	-	-	-	-	-	-				
Menu 3: Soft run OPEN position														Set using the (+ / OPEN) and (- / CLOSE) buttons						
Menu 4: CLOSE speed														← Slower		Faster →				
12	-	-	-	-	5	6	7	8	9	10	11	12	13	14	15	16				
Menu 6: Soft run CLOSE speed														← Slower		Faster →				
7	1	2	3	4	5	6	7	-	-	-	-	-	-	-	-	-				
Menu 8: Soft run CLOSE position														Set using the (+ / OPEN) and (- / CLOSE) buttons						

12. ADVANCED SETTINGS (cont'd)

Level 7 – Maintenance and servicing

Menu 1: Door cycle counter
Six-figure indicator showing the number of complete cycles, up to 999999. Once the counter setting is reached, it restarts count again.
Menu 2: Servicing counter
Five-figure indicator showing the number of complete cycles left up to maintenance indication. Figures shown one after the other up to the indicator point, then repeated.

Menu 3: Service/Maintenance Counter Setting

Adjustment of the number of door operations to be completed before a servicing reminder is displayed.

1	OFF Default
2	100 door operations
3	500 door operations
4	1,000 door operations
5	4,000 door operations
6	5,000 door operations
7	6,000 door operations
8	7,000 door operations
9	8,000 door operations
10	9,000 door operations
11	10,000 door operations
12	15,000 door operations
13	20,000 door operations
14	30,000 door operations
15	40,000 door operations
16	50,000 door operations



Menu 8: Reset maintenance and servicing

The fault log for maintenance, diagnostics and servicing work is reset here.

1	No Reset - Default Setting
2	Reset the fault log

Menu 9: Fault indicator

Shows the current fault message.
(No more than 16 fault messages can be viewed).

	Display the previous fault / Navigate through the list of faults
	Navigate through the list of faults

Level 8 - CLOSE Travel Position Pressure Sensitivity Adjustment (PSA™)

1	Default not activated
2	Short
3	Medium
4	Long

13. REMOTE CONTROLS

⚠ WARNING ⚠

Danger of injury due to uncontrolled operation of the door!

- Operate the controls or the hand transmitter only when there are no persons or objects in the path of the door.
- Ensure that the controls and the hand transmitter are never used by children or unauthorized persons.
- Ensure that the hand transmitter cannot be operated by accident (in a trouser pocket, for example).

FCC Certified: This device complies with Part 15 of the FCC rules. Operation is subject to the following two conditions: (1) this device may not cause harmful interference, and (2) this device must accept any interference received, including interference that may cause undesired operation.

Changes or modifications not expressly approved by the party responsible for compliance could void the user's authority to operate the equipment.

13-1. TRANSMITTER

A family of state-of-the-art transmitters, each transmitter is custom encoded with installed battery. Offered in two styles to suit your personal preference. See Fig. 48.

- Mini (2-or 4-channel)
- Micro (3-channel) with keyring attachment.

TRANSMITTER MOUNTING:

The transmitters can be conveniently mounted inside your car using the visor clip or on the wall using the mounting plate.

Visor Clip (Fig. 49)

- Remove visor compartment cover.
- Snap visor clip into transmitter.
- Affix assembly to visor.

Mounting Plate (Fig. 49A)

- Secure the mounting plate to area of preference using screw and anchor.
- Slide the transmitter into the mounting plate, which will hold it firmly in place.

MULTIPLE TRANSMITTERS (Fig. 50):

Each transmitter comes factory programmed with random codes. 2-channel transmitters have 2 different random codes, one per button, 3-channel transmitters have 3 different random codes and 4-channel transmitters have 4 different random codes, one per button. Transmitters that are purchased separately as accessories have random codes that must be changed in order to match the code of the "active" transmitter, which you are already using. Below are instructions for transferring an active code from a button on one transmitter to a button of your choice on another transmitter.

- Connect the transmitter with active code to the new transmitter using the programming connector. (Fig 50)
- Press and hold the selected channel button on the transmitter with the active code.
- Press and hold the respective channel button on the new transmitter. The light in the transmitter initially starts blinking and then illuminates continuously after 1-2 sec. Code transfer is completed.
- Programming connector can be removed and both transmitters can now be used to operate the same opener.

NOTE: For multi-button transmitters, be sure to carry out this procedure for all the buttons you desire to use.

Fig. 48

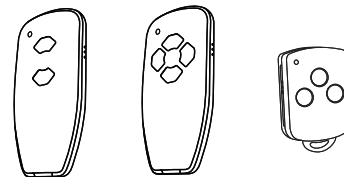

Fig. 49

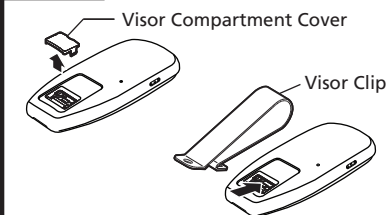

Fig. 49A

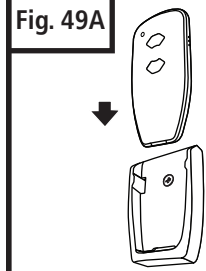
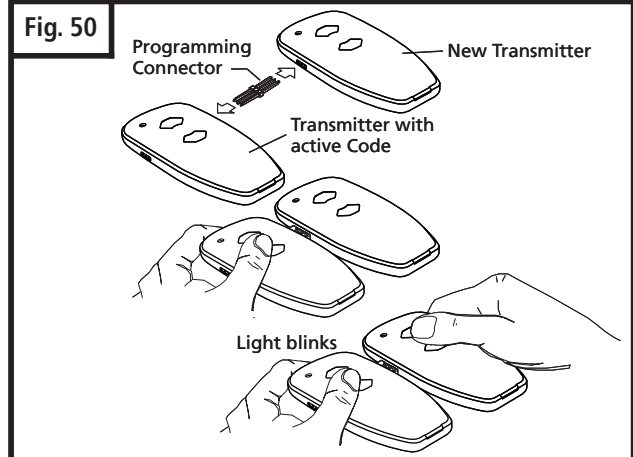

Fig. 50



13-1. TRANSMITTER (cont'd)

CHANGING THE CODE (Fig. 51):

The transmitter factory preset code can be changed as follows:

- Insert the programming connector into transmitter terminal.
- Short one of the outer pins of the programming connector with the middle pin.
- Press and hold the respective channel button. The light will blink rapidly for approximately 5 sec. Release the button after the light illuminates continuously. Code will change in approximately 2 seconds.
- Remove the programming connector.
- Once the transmitter code is changed, the operator must be recoded with the new transmitter code as described on the initial system set up on page 21.

NOTE: For multi-button transmitters, be sure to carry out this procedure for all the buttons you desire to use.

BATTERY REPLACEMENT (Fig. 52):

- Open transmitter.
- Insert a 3V battery (type CR2032) as shown.
- Close the transmitter.

NOTE: Replace batteries with same type only.

Fig. 51

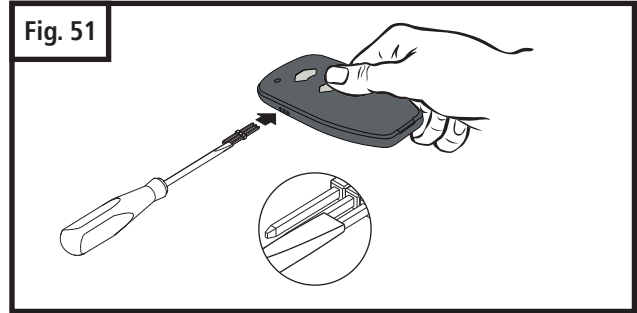
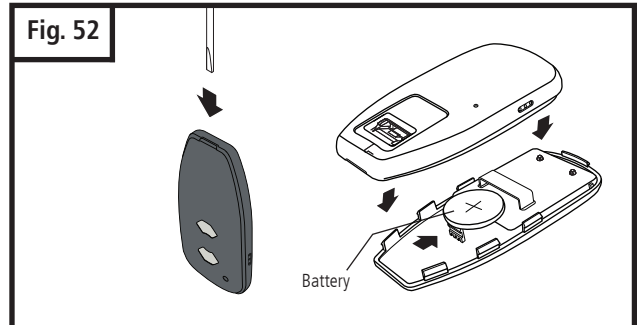

Fig. 52



13-2. WIRELESS KEYLESS ENTRY SYSTEM (OPTIONAL ACCESSORY)

The **Wireless Keyless Entry System** offers you the convenience of opening and closing your garage door by entering your own 4-digit Personal Identification Number (PIN) via the keypad. The WKE can be programmed wireless to control up to 4 garage door operators that each work on a different code, or to control one garage door operator with up to 4 different PINs. You can also program it to allow a temporary PIN of your choice to be stored, to provide temporary access to authorized visitors or service people.

⚠ WARNING ⚠

To prevent possible **SERIOUS INJURY** or **DEATH** from a moving garage door:

- Install **Wireless Keyless Entry System** within sight of the garage door, out of reach of children at a minimum height of 5 feet (1.5m) and away from **ALL** moving parts of the door.
- **ALWAYS** keep remote controls out of reach of children. **NEVER** permit children to operate, or play with remote controls.
- **Activate door ONLY** when it can be seen clearly, is properly adjusted, and there are no obstructions to door travel.
- **ALWAYS** keep garage door in sight until completely closed. **NEVER** permit anyone to cross path of moving door.

PROGRAM PIN AND TRANSFER CODE

- Install batteries provided in WKE, Fig. 56.
- Remove metal clip from transmitter.
- Press and hold ③ button for at least 3 seconds to activate programming mode, **LED's light up for 10 seconds.**
- Immediately, aim the top of transmitter very close to buttons ⑤ and ⑥.
Press and hold button you use to operate the door and move transmitter slowly down toward the number ⑧ and ⑨ button area.
Release transmitter button when LED's on keypad flash.
- Immediately, enter a 4-digit personal identification number (PIN) of your choice **###**.
- Immediately, press and release the **ENTER** ④ button. LED's and keypad buttons will light up for 2 seconds signaling programming is completed.
- Test WKE by entering the PIN, then press **ENTER** ④ button.

NOTE: To program the WKE to more than one garage door operator (maximum 4), repeat the steps above using a new PIN for each additional garage door operator.

Fig. 53

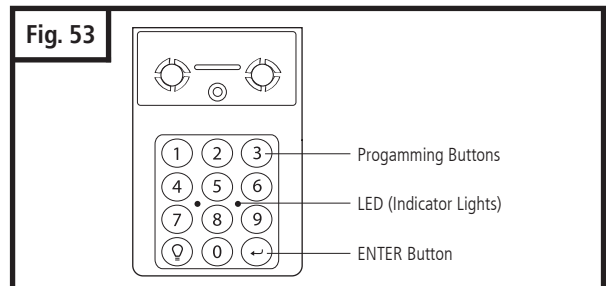
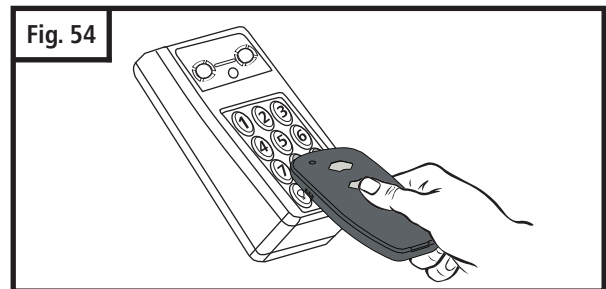

Fig. 54



13-2. WIRELESS KEYLESS ENTRY SYSTEM (cont'd)

CHANGE AN EXISTING PIN

- Press **⓪** button for at least 3 seconds, LED's will flash slowly. Release **⓪** button.
- Enter the programmed PIN that you want to change. Press the **ENTER** **⓪** button. LED's will flash rapidly.
- Enter the new 4-digit PIN of your choice **####** then press the **ENTER** **⓪** button. **LED's and keypad light up for 2 seconds.**
- To test WKE, enter the new PIN then press the **ENTER** **⓪** button. The garage door opener will activate.

PROGRAM A TEMPORARY PIN

A temporary 4-digit PIN can be programmed to allow access to visitors. Each programmed PIN can program one temporary PIN. The temporary PIN can be set for a number of door openings (max 99). The temporary PIN cannot be the same as any previously programmed PIN.

- Press **⓪** button for at least 3 seconds.
LED's will flash slowly for 10 seconds.
- NOTE:** To successfully establish a temporary pin, steps 2-4 must be completed within 10 seconds after programming activation.
- Enter any programmed PIN, then press **ENTER** **⓪** button.
LED's will flash rapidly.
- Enter the temporary 4-digit PIN of your choice **####** then press the **ENTER** **⓪** button. **LED's will flash very rapidly.**
- Press the number of openings the temporary PIN will work (up to 99). Then press the **ENTER** **⓪** button.
LED's and key pad buttons light up for 2 seconds then system goes in stand-by mode.

To test, enter the temporary PIN, then press the ENTER button. The garage door operator will activate. If the temporary PIN was set for a number of openings, the test will use up one opening programmed PIN.

NOTE: To clear the temporary PIN, repeat steps 1-3 above, setting the number of openings to "0" in step 4.

CLEARING WKE Memory

- Remove Wireless Keyless from wall mounting plate.
- Remove batteries from Wireless Keyless.
- Press and hold **ENTER** **⓪** button.
- Install batteries back. Match polarity designation.
- Release **ENTER** **⓪** button, LED flash rapidly approximately 5 seconds.

14. OPERATION OF YOUR OPERATOR

The garage door operator can be activated through the following accessories:

WIRELESS KEYLESS ENTRY SYSTEM

The garage door operator activates when the PIN and **ENTER** **⓪** button are pressed. The keypad will blink for 28 seconds, during that time the **ENTER** **⓪** button can be used to stop, start, reverse the door.

If the wrong number is accidentally pressed, press the correct PIN then the **ENTER** **⓪** button. The Keyless Entry will transmit only the last four digits.

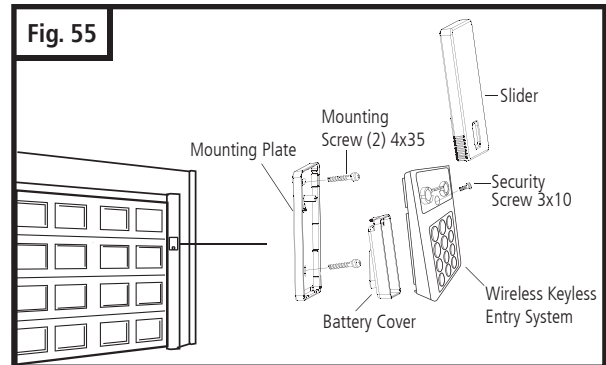

INSTALLATION

- Select a location to mount the Keyless Entry at a minimum height of 5 feet (1.5m) out of the reach of children.
- Use mounting plate as template, mark hole location and then drill two 1/8 inch (3.2mm) pilot holes.
- Secure plate to the mounting surface with the (2) screws provided. Do not over-tighten screws to avoid cracking the plastic.
- Cover batteries with battery cover.
- Snap WKE into the mounting plate and secure with screw provided. See Fig. 55.
- Install slide-up protective cover. Align cover slides with slide grooves on WKE and slide cover down until it locks.

BATTERY

⚠ WARNING ⚠

To prevent possible **SERIOUS INJURY** or **DEATH**:
NEVER allow small children near batteries.
If battery is swallowed, immediately notify doctor.

Low Battery Indicator:

Replace the batteries (AAA) when all the keypad buttons start to flash (10 seconds) upon raising the Wireless Keyless protective cover.

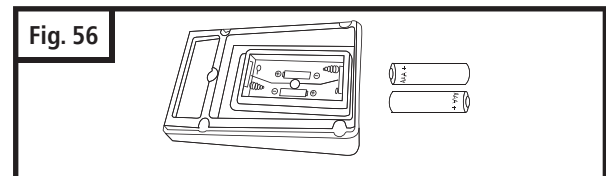

ONE-BUTTON-TO-CLOSE: The Keyless Entry has a feature that allows the door to be closed using the ENTER button instead of a PIN.

NOTE: Factory setting-active.

To deactivate the one button close feature:

- Press the **⓪** button for 3 seconds. LED on keypad flash slowly.
- Press the **ENTER** **⓪** button.
- The keypad LED's light up for 2 seconds indicating that the one button close feature has been deactivated.

To activate the one button close feature:

- Press the **⓪** button for 3 seconds. LED on keypad flash slowly.
- Press the **ENTER** **⓪** button.
- The keypad LED's light up for 2 seconds indicating that the one button close feature has been activated.

14. OPERATION OF YOUR OPERATOR (cont'd)

REMOTE CONTROL TRANSMITTER:

- To open or close garage door, press and hold designated button (Transmitter has an indicator light that will illuminate). See Fig. 57. When garage door begins to move, release button.
- To stop garage door during travel, press and hold button until door stops, then release button.
- To resume garage door travel after stopping, press button again. Door begins to move in the opposite direction.

WALL CONTROL PANEL:

- The Door Pushbutton will light when Wall Control properly connected (if it does not light up, review section 8-14 "Install Wall Control" on page 18. To open or close garage door, press and hold Illuminated Door Pushbutton. See Fig. 58. When garage door begins to move, release button. To stop garage door during travel, press and hold button until door stops, then release button. To resume garage door travel after stopping it, press button again. Door begins to move in the opposite direction.
- The Light On / Off button can be used to turn lights on or off.

NOTE: The operator light will dim down when turned off.

When using the light On / Off button, the automatic timer is ignored, and the lights will remain on until the button is pressed again, or until the operator is activated and the automatic timer begins again.

- The Lock/Vacation button can be used to lock out all remote control transmitters. The door can still be activated by wall control panel or keyless entry system. Press and hold Lock/Vacation button for 2-3 seconds. Release button. Illuminated Door Pushbutton will flash continuously while lock mode is active. To unlock opener, press and hold Lock/Vacation button for 2-3 seconds.

Important Note: If the vacation lock mode is engaged.

By pressing and holding the door activation button for one second or longer will disengage the vacation lock mode.

OPERATOR LIGHT:

- Light will come on whenever operator is activated. The default factory setting for the light to stay "on" is 4 minutes and 15 sec., or until the Light On / Off button on the wall control panel is pressed, whichever is sooner.
- Light can be turned on and off manually as described under operation of wall control panel.
- Light will flash when the operator senses an obstruction either detected by the internal safety system or the photo eye sensors. To stop light from flashing, remove obstruction and operate door normally. The fault light indicator will flash for the set light time "on" factory default setting of 4 minutes 15 sec. maximum.

Fig. 57

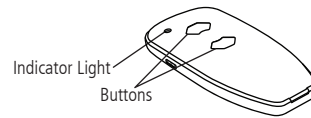

Operating the door using a hand transmitter

1.		The control system is in operating mode.	
2.		Impulse The door moves in the OPEN direction	
3.		Impulse The operator system stops.	
4.		Impulse The door moves in the opposite direction (CLOSE direction).	

Fig. 58

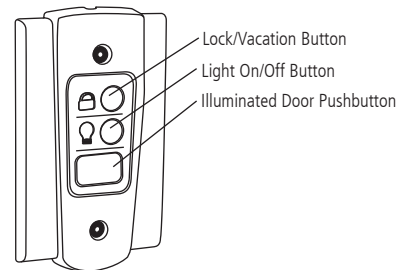
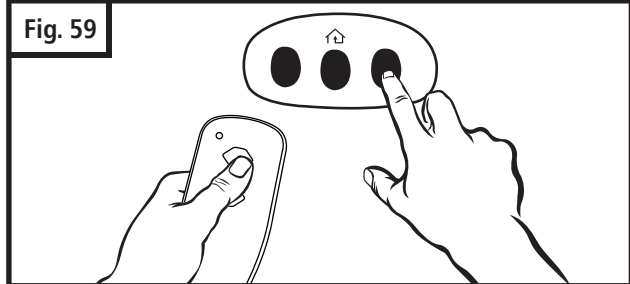

Fig. 59



15. HOMELINK® TRANSCIEVER

Before you can use your car's HomeLink® device to open a garage door you must transfer an active code from the transmitter to the HomeLink® Universal transceiver. (Reference - HomeLink® Manual) (See Fig. 59)

- Clear memory in HomeLink® transceiver per manufacturer instructions.
- Make sure the door path is clear and the door is in the line of site at all time during the set up.
- Start the programming sequence by pressing the transmitter button and the HomeLink® transceiver button on console simultaneously. Follow manufacturer instructions to complete programming sequence. **No learn button on the operator is required to be pressed.**
- Repeat steps above for the other channels available.

16. TEST SAFETY REVERSAL

The safety reversal function of your operator is an extremely important feature of your operator. Testing this function ensures the correct operation of your operator and door.

The reversal system test should be performed:

- Once per month.
- Anytime the travel or force limits are reset or changed. Once the adjustments have been set and the door has been run up and down twice to “learn” the new settings, you must test the reversal system for proper operation.
- Place a 1-1/2" (40mm) high rigid object (or a 2x4 board laid flat) on the floor directly in the path of the door. See Fig. 60.
- Start the door in the downward direction and watch what happens.
- When door contacts the object (or 2x4), it should stop, reverse, and automatically return to the fully opened position.
- If the door does not reverse, reset the down travel limit so that the door travels slightly further down in the closed direction. Then, retest the unit as described above.
- If the door still does not reverse, disconnect your operator and call a service person.

17. ALIGN AND TEST PHOTO EYE SENSORS

PHOTO EYE SENSORS ALIGNMENT:

The photo eye sensors maintain an invisible, unbroken beam between each other. See Fig. 61.

NOTE: Sensor alignment must be done with the door in the closed position in order to ensure proper visibility of the sensor indicator LED.

- When the photo eye system is connected to the operator and the power is on, the green light on the transmitter sensor flashes, if the sensors are not aligned. When the sensors are aligned, the green light on the transmitter sensor will turn steady. See Fig. 62.
- Sensors must be installed parallel to the door plane and make sure the sensors are facing each other.

AFTER THE SENSORS HAVE BEEN PROPERLY ALIGNED. MAKE SURE THAT THE SYSTEM OPERATION AND SAFETY TESTS OUTLINED BY THE GARAGE DOOR OPENER MANUFACTURER HAVE BEEN VERIFIED.

SAFETY TEST:

Photo eye sensors installed on opposite sides of your door opening are intended to detect a person or object in the path of the door and prevent the door from moving downward. The following steps will determine if the system is functioning properly:

- Open door using the operator's transmitter or wall control.
- Place a box or other object in the path of the door so it breaks the photo eye beam. See Fig. 63.
- Press and release the wall control button. The door should not move in the down direction. If this does not happen, disconnect operator and call for service.
- To reset operator, remove the obstruction and operate the door normally.
- If photo eye sensors are not aligned or are damaged, door can only be closed by pressing and holding wall control button until door is fully closed.

Fig. 60

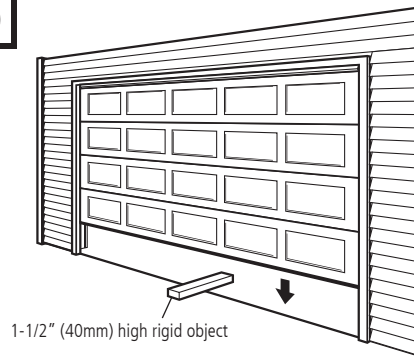

Fig. 61

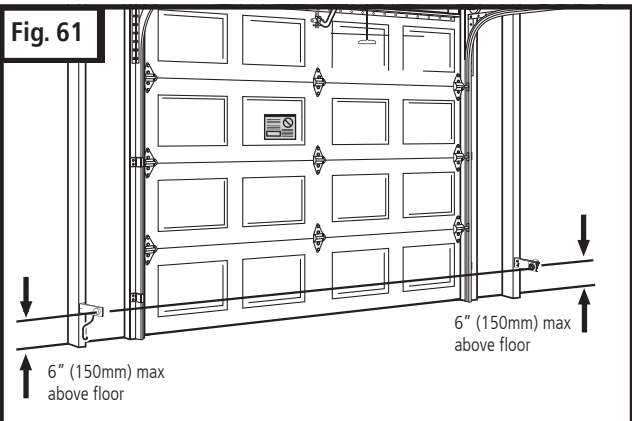

Fig. 62

Clear Path between Photo Eye Sensors

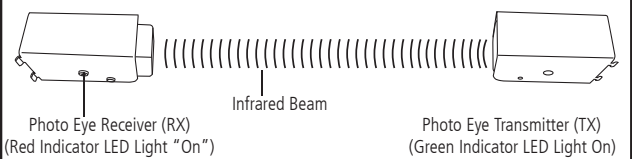
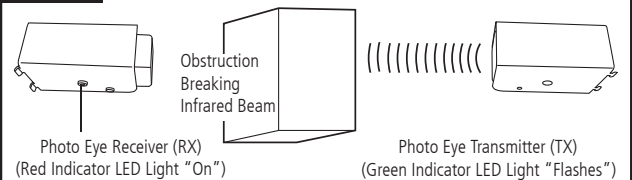

Fig. 63

Object directly in Path between Photo Eye Sensors



18. APPLY LABELS TO INSIDE OF GARAGE

Several important safety and instruction labels are included with your operator package. These labels must be posted inside your garage where they can be easily seen by all. We recommend installing them in the location shown in Fig. 9 on page 9. To affix the labels, peel off the protective backing, and stick onto smooth, clean surface. If labels don't adhere well to surface, use tacks (wood door only) or additional adhesive to securely affix in place. **DO NOT PAINT OVER ANY LABELS.**

19. ATTACH OWNER'S MANUAL TO WALL

It is important that the manual be stored where it can be referred to later in case adjustments need to be made, and / or new controls or accessories added. Store the manual in a safe, easily accessible location. We recommend you use an envelope with an eyelet to store the manual in the garage on a nail or hook on the wall near the wall control.

20. IMPORTANT SAFETY INSTRUCTIONS

IMPORTANT SAFETY INSTRUCTIONS



TO REDUCE THE RISK OF SEVERE INJURY OR DEATH:

1. **READ AND FOLLOW ALL WARNINGS AND INSTRUCTIONS CAREFULLY.**
2. Never let children operate or play with door controls. Keep the remote control away from children.
3. Always keep the moving door in sight and away from people and objects until it is completely closed. **NO ONE SHOULD CROSS THE PATH OF THE MOVING DOOR.**
4. NEVER GO UNDER A STOPPED, PARTIALLY OPEN DOOR.
5. Test door operator monthly. The garage door **MUST** reverse on contact with a 1-1/2" (40mm) high object (or a 2x4 laid flat) on the floor. After adjusting either the force or the limit of travel, retest the door operator. Failure to adjust the operator properly may cause severe injury or death.
6. If possible, use the emergency release only when the door is closed. Use caution when using this release with the door open. Weak or broken springs may allow the door to fall rapidly, causing severe injury or death.
7. **KEEP GARAGE DOORS PROPERLY BALANCED.** See Garage Door Owner's Manual. An improperly balanced door could cause severe injury or death. Have a qualified service person make repairs to cables, spring assemblies, and other hardware.
8. Disconnect the electrical power to the garage door operator before making any repairs or removing the housing cover.
9. **SAVE THESE INSTRUCTIONS** for future safety, adjustment, and maintenance purposes.

21. TENSION ADJUSTMENT

Your preassembled rail comes with the tension adjusted to factory specifications. There should be no need for further adjustment. However, if exposed or subjected to unusually harsh operating conditions, the tension may need to be readjusted during the life of the opener.

CHECK PROPER TENSION (Fig. 64):

- Release trolley from belt or chain, then examine the setting of the tension adjustment at the header end of the rail.
- Proper tension is set when the tension nut is tightened just enough so that the washer will be spaced approximately 18.5mm (or 3/4") from the stationary rail end-stop arch.
- If the gap between the washer and the rail end-stop arch is too big or too small, the tension needs to be adjusted.

ADJUST THE TENSION:

- To increase the tension and tighten the belt or chain, turn the tension nut clockwise with 7/16" wrench until the washer is spaced properly from the rail end-stop arch. See Fig. 64.
- Once the washer is spaced correctly, any additional tightening will overtighten the belt or chain and may cause damage to the system.
- To loosen the tension, turn nut counterclockwise.
- Reattach trolley.

Fig. 64

Proper Tension Adjustment

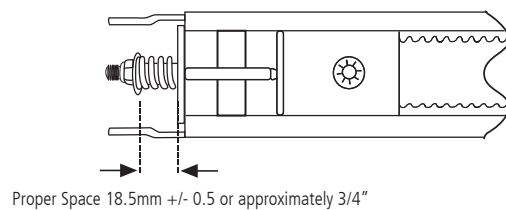

22. RAIL LENGTH ADJUSTMENT

FOR PROFESSIONAL INSTALLERS ONLY

If your particular installation calls for a shorter rail than the standard length provided, it is possible to shorten the rail.

NOTE: Shortening rail too much may result in door travel length reduction and door not opening fully. This depends on door size and configuration. Carefully plan all such modifications before proceeding. **THIS PROCEDURE SHOULD BE PERFORMED ONLY BY A PROFESSIONAL INSTALLER FULLY FAMILIAR WITH THIS TYPE OF OPENER SYSTEM.**

TO SHORTEN BELT RAIL LENGTH:

- Loosen belt tension as much as possible.
- Remove screws from sprocket holder and rail end-stop.
- Slide belt and all rail parts out of rail from header end. See rail exploded view, Fig. 67 on p. 33, for disassembly details.
- Measure and cut off excess rail from header end.
- Using rail end-stop as a guide, mark and drill a 3/16" hole for rail end-stop screw.
- Disassemble connector to expose free ends of belt.
- Using the same measurement as the excess rail length, cut the same amount off BOTH free ends of the belt.
- Reassemble belt connector, and slide all rail parts into rail from header end according to original assembly (Fig. 67).
- Tension belt properly (Fig. 64).
- Check rail for proper assembly and operation by manually moving trolley from end to end with trolley connected to belt.

Fig. 65

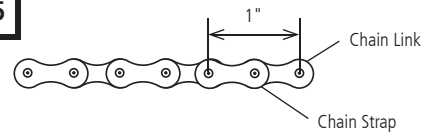

TO SHORTEN CHAIN RAIL LENGTH:

- Loosen chain tension as much as possible.
- Remove screws from sprocket holder and rail end-stop.
- Slide chain and all rail parts out of rail from header end. See rail exploded view, Fig. 68 on p. 33, for disassembly details.
- Measure and cut off excess rail from header end by 1" increment only.
- Using rail end-stop as a guide, mark and drill a 3/16" hole for rail end-stop screw.
- Disassemble connector to expose free ends of chain.
- Using the same measurement as the excess rail length, remove the same amount off chain links and chain straps from BOTH free ends of the chain (Fig. 65).
- Reassemble two piece connector and slide chain and all rail parts into rail from header end according to original assembly (Fig. 68).
- Tension chain properly (Fig. 64).
- Check rail for proper assembly and operation by manually moving trolley from end to end with trolley connected to chain.

23. RAIL PARTS (HEAVY DUTY RAIL)

Fig. 66

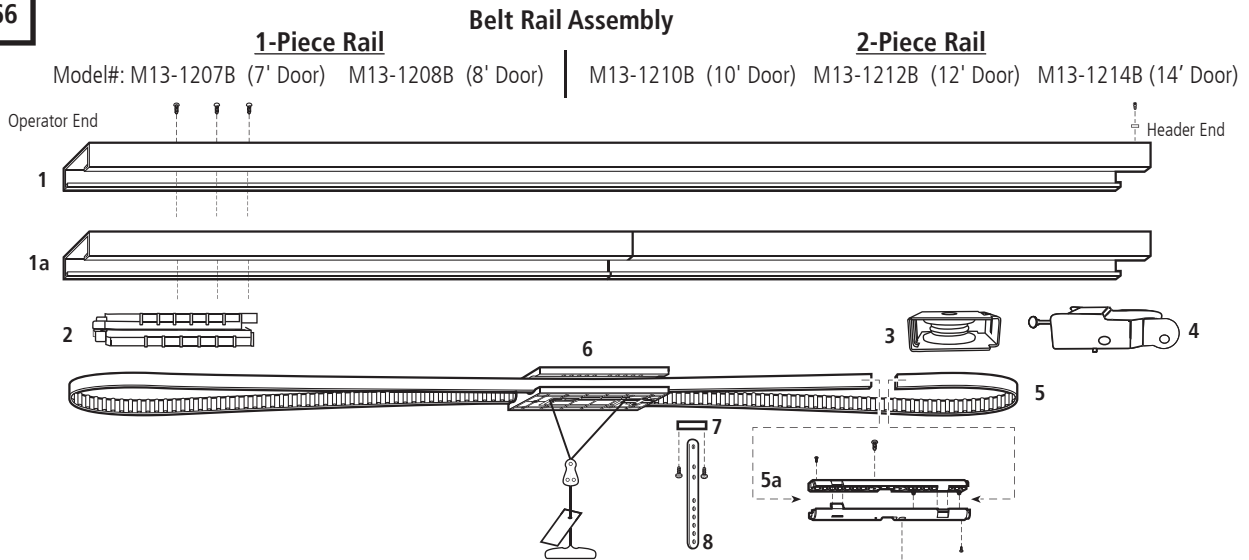

Item Part #	Description	Item Part #	Description
1.	1 piece rail	6.	115443 Trolley with connector (7' Door)
1a.	2 piece rail set	115444	Trolley with connector (8' Door)
2.	88824 Sprocket holder assembly	115445	Trolley with connector (10' Door)
3.	95358 Roller holder assembly	115446	Trolley with connector (12' Door)
4.	91566 Rail end assembly	115447	Trolley with connector (14' Door)
5.	Belt	7.	73636 Pin
5a.	8030196 Belt connector	8.	8030735 Straight door arm

24. RAIL PARTS (STANDARD RAIL)

Fig. 67

Belt Rail Assembly

Model#: M13-807B (7' Door) M13-808B (8' Door) M13-810B (10' Door)

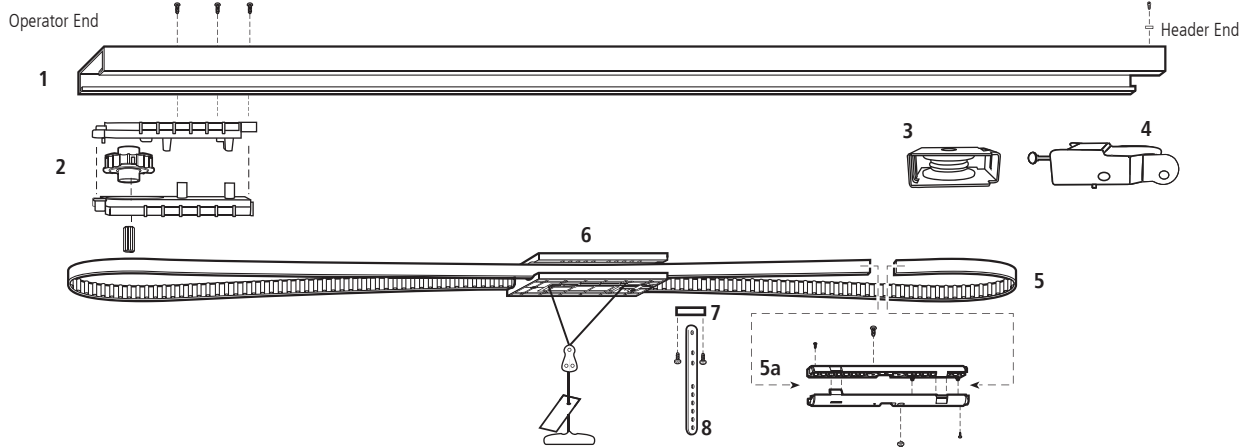

Item Part #	Description	Item Part #	Description
1. ———	Rail	6. 115443	Trolley with connector (7' Door)
2. 91567	Sprocket holder assembly	115444	Trolley with connector (8' Door)
97484	Shaft adapter	115445	Trolley with connector (10' Door)
3. 95358	Roller holder assembly	7. 73636	Pin
4. 91566	Rail end assembly	8. 8030735	Straight door arm
5. ———	Belt		
5a. 8030196	Belt connector		

Fig. 68

Chain Rail Assembly

Model#: M13-807C (7' Door) M13-808C (8' Door) M13-810C (10' Door)

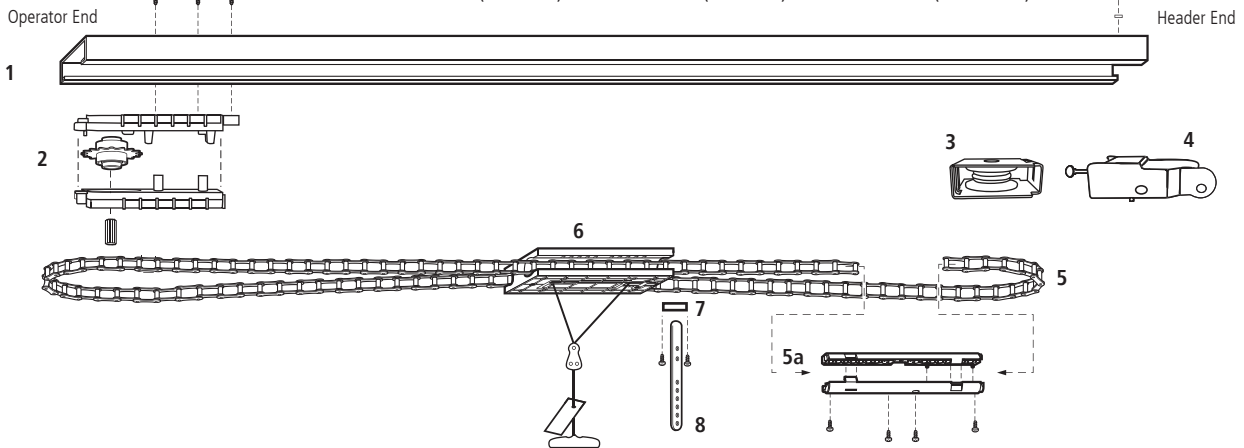

Item Part #	Description	Item Part #	Description
1. ———	Rail	6. 115443	Trolley with connector (7' Door)
2. 91568	Sprocket holder assembly	115444	Trolley with connector (8' Door)
97484	Shaft adapter	115445	Trolley with connector (10' Door)
3. 95358	Roller holder assembly	7. 73636	Pin
4. 91566	Rail end assembly	8. 8030735	Straight door arm
5. ———	Chain		
5a. 8030234	Chain connector		

25. OPERATOR PARTS

Fig. 69

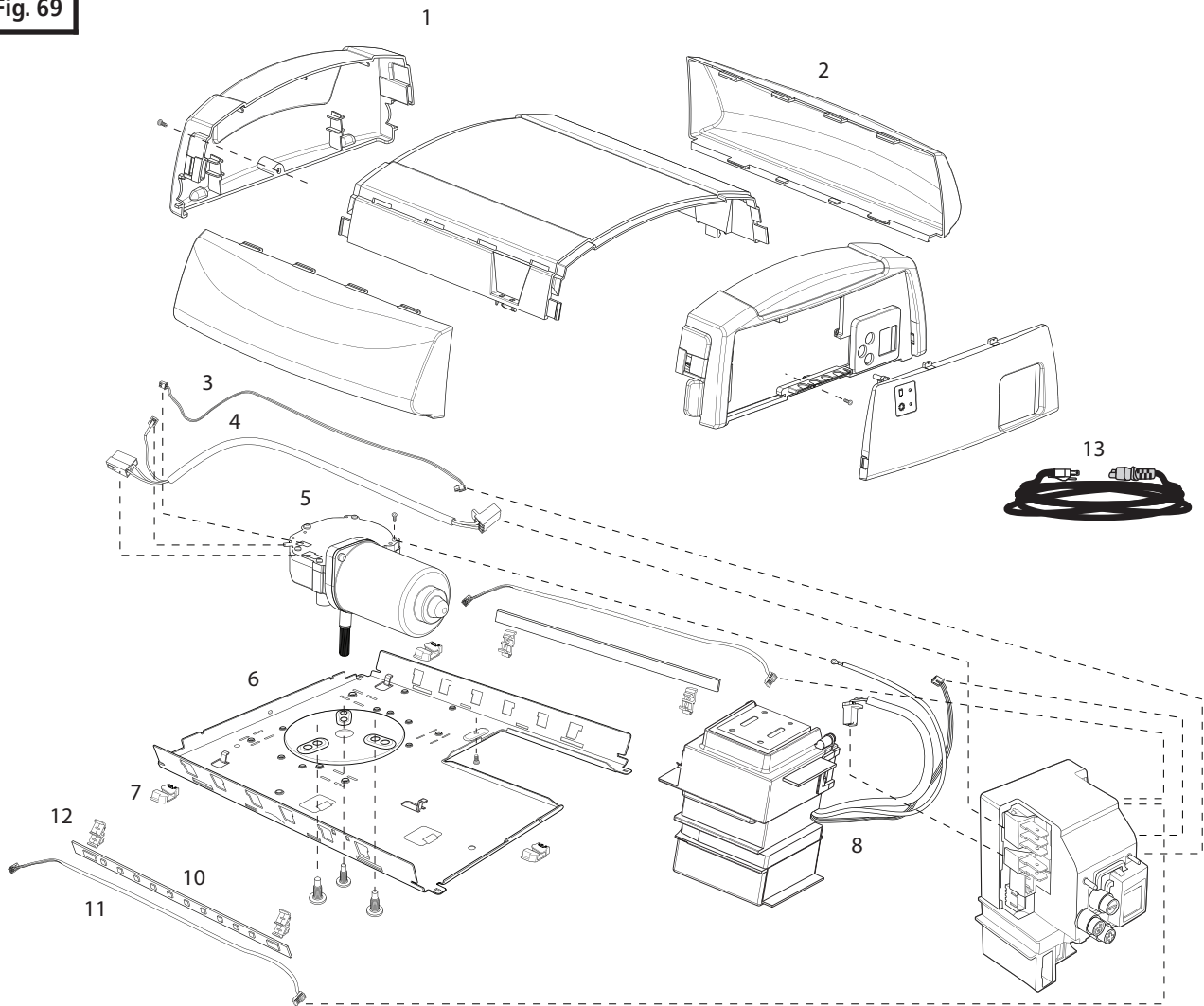

Item	Part #	Description
1.	122947	Housing set
2.	116350	Lens cover set
3.	—	Wire (motor / control box)
4.	—	Wire harness (motor / control box)
5.	102277	Gearmotor (360 / 370)
	102276	Gearmotor (380)
6.	—	Chassis
7.	—	Wire holder
8.	122945	Transformer box (360)
	105470	Transformer box (370 / 380)
9.	116422	Control box
10.	114676	LED strip
	101161	LED strip set
11.	—	Wire (LED strip/ control box)
12.	98668	LED holder
13.	105475	Detachable Power Cord

26. ACCESSORIES

Fig. 70

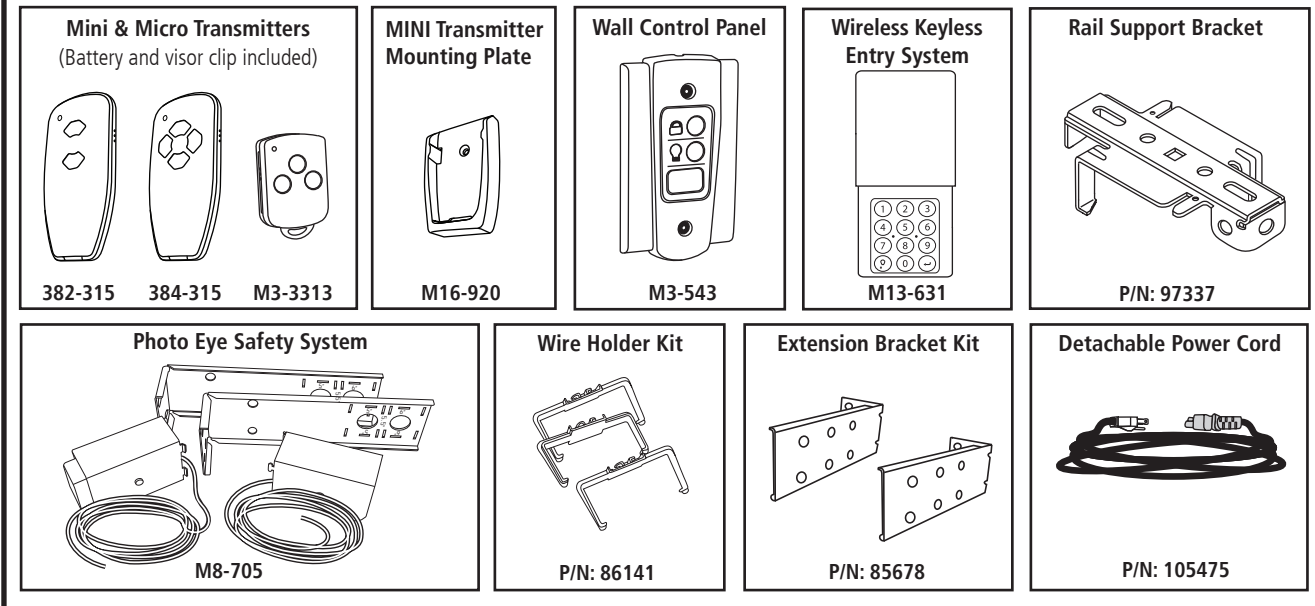

26-1. LED EL 300



Danger of electric shock:
Before any wiring work begin, make sure that the operator and all wiring is disconnected from the power supply. During wiring make sure all wires remain disconnected from the power supply at all times.

Assemble LED Strips (Fig. 71):

- Attach cables to LED strips.

LED Strips Installation:

- Disconnect power cord from operator (Fig. 72).
- Remove lens covers.
- Attach first LED strip to existing strip and snap into holders (Fig. 73).
- Attach second LED strip to existing strip and snap into holders (Fig. 73).
- Replace lens cover.
- Connect power cord to operator.

Fig. 71

LED Strips
P/N: 101161

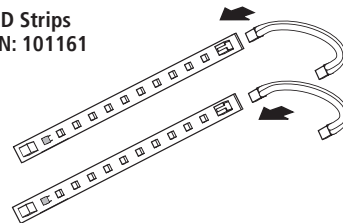

Fig. 72

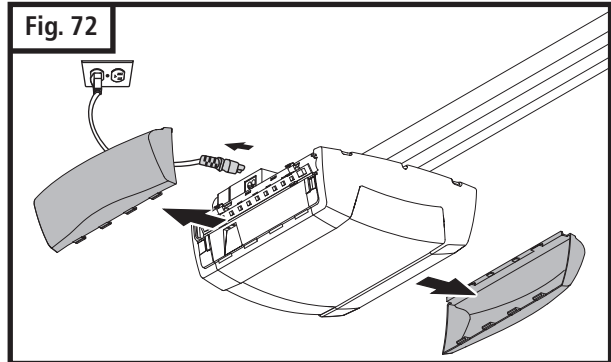
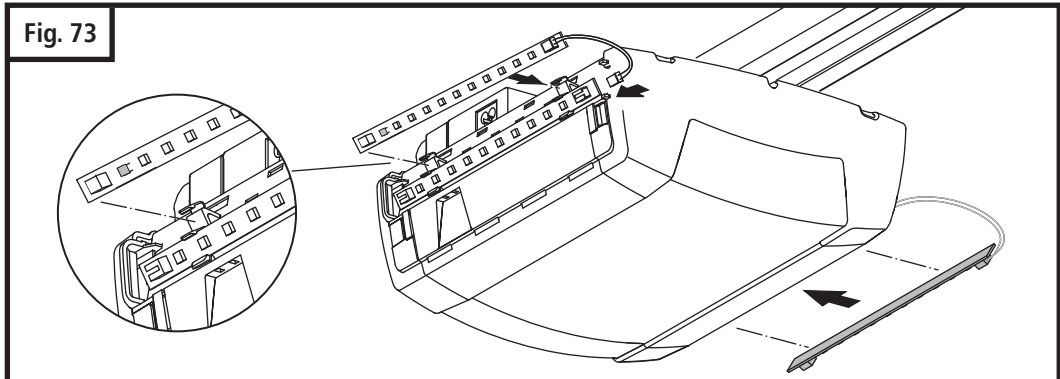

Fig. 73



26-2. EXTENSION BRACKET KIT

- Locate the mounting position for extension bracket as shown in Fig. 74A.
- Secure the bracket to the wall with two lag screws 1/4" x 1 1/2" provided in operator's hardware kit.
- Attach photo eye bracket to extension bracket and secure with hardware provided.
- Repeat process for the other bracket.

26-3. PERMANENT WIRING KIT

If permanent wiring is required by your local code refer to the procedure below.

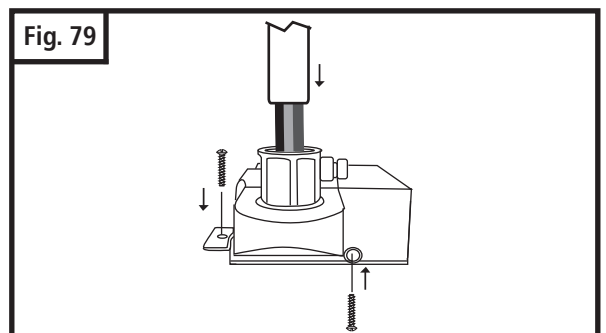
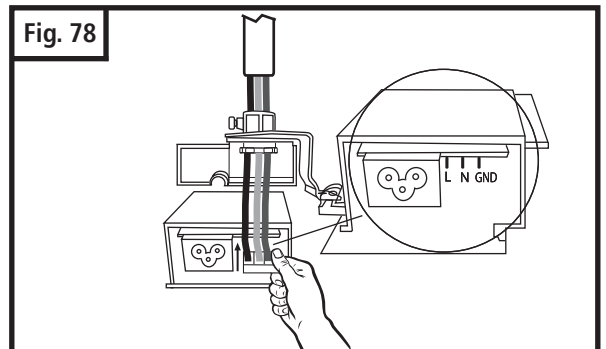
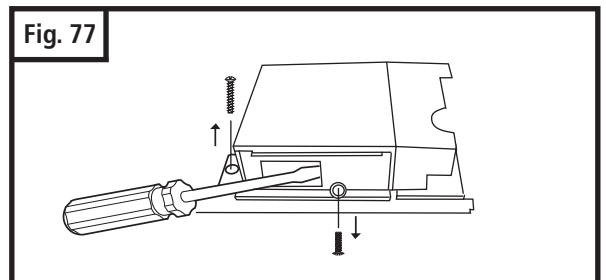
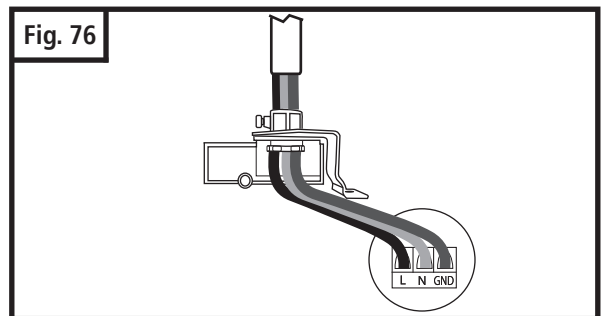
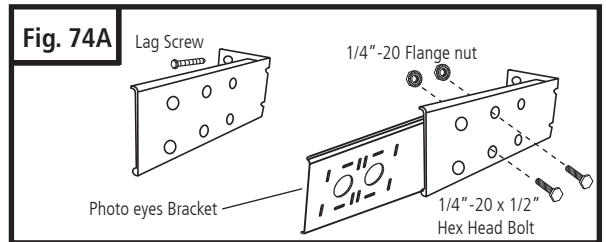
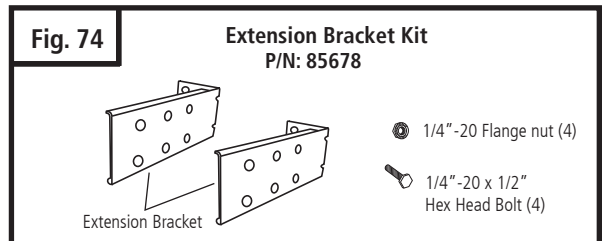
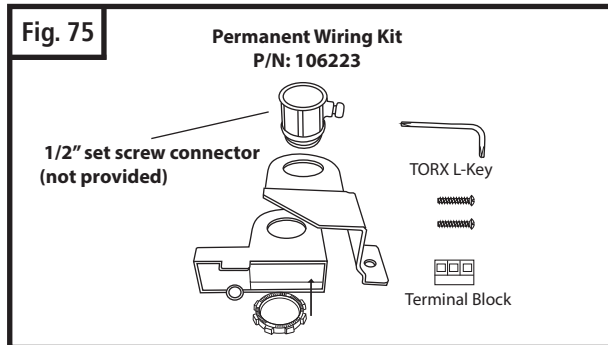

⚡ WARNING ⚡

To prevent possible **SERIOUS INJURY** or **DEATH** from electrocution or fire:

- Be sure power is not connected to the operator, and disconnect power at circuit breaker **BEFORE** removing cover to establish permanent wiring connection.
- Garage door installation and wiring **MUST** be in compliance with **ALL** local electrical and building codes.
- **NEVER** use an extension cord, 2-wire adapter or change plug in any way to make it fit outlet. Be sure the opener is grounded.

- Become familiar with assembly parts shown in Fig. 75 for 1/2" conduit permanent wiring installation..
- Assemble conduit adapter, use parts as shown in Fig. 75.
- Feed wires through conduit adapter assembly. Then connect field wires to terminal block as shown in Fig. 76.
- Remove screw from transformer module cover plate. Break cover plate as shown in Fig. 77. Remove and save chassis screw.
- Slide power board slightly out to make room to accept terminal block on the power board pin connections as shown in Fig. 78*.
- * **Make sure the power board is seated on the transformers module housing guides before sliding it back in place.**
- Secure conduit adapter assembly to transformer module enclosure, as shown in Fig. 79, with screw provided in kit. Metal bracket secure to chassis with screw removed in step 2.
- Run field wires through conduit.
- Secure conduit to screw connector on assembly as shown in Fig. 79.
- Terminate and complete field wiring connection.

IMPORTANT NOTE:

Check installation then turn power "on" at breaker.

WARNING

IMPORTANT INSTALLATION INSTRUCTIONS TO REDUCE THE RISK OF SEVERE INJURY OR DEATH:

1. READ AND FOLLOW ALL WARNINGS AND INSTALLATION INSTRUCTIONS.
2. Use only the following **Model WP1.2-12 (Sealed cell, lead acid batteries with pressure release vents) and battery(ies) size 12V 1.2Ah.**
3. Do not dispose of the battery(ies) in fire. The cells may explode. Check with local codes for possible disposal instructions. Note: not applicable for battery(ies) not intended to be replaced.
4. Do not open or mutilate the battery(ies). Released electrolyte is corrosive and may cause damage to the eyes or skin. It may be toxic if swallowed.
5. Exercise care in handling battery in order not to short the battery with conducting materials such as rings, bracelets, and keys.
6. Change the battery(ies) provided with or identified for use with this product only in accordance with the instructions and limitations specified in this manual.
7. Observe proper polarity orientation between the battery(ies) and charging circuit.
8. Do not mix battery(ies) of different sizes or from different manufacturers in this product
9. A battery-operated product employing a secondary supply intended to be charged within the product shall contain specific instructions concerning the proper method of charging.

WARNING

To reduce the risk of FIRE or INJURY:

- **Disconnect ALL electric and battery power BEFORE performing ANY service or maintenance.**
- **For continued protection against fire, replace FUSE only with Type Littlefuse Blade Fuse Series 257 rated 15 Amps, 32VDC**
- **ALWAYS wear protective gloves and eye protection when changing the battery or working around the battery compartment.**

Energy Pack Installation:

- Disconnect power cord from operator (Fig. 81).
- Remove back cover (Fig. 81).
- Insert mounting plate (Fig. 82).
- Install energy pack and connect wire harness to connector XN70 (Fig. 83,84).
- Insert fuse (Fig. 85).
- Insert light guide into back plate and snap plate back in place (Fig. 86).
- Connect power cord to operator (Fig. 87).

26-4. ENERGY PACK 100 (BATTERY BACKUP) (cont'd)

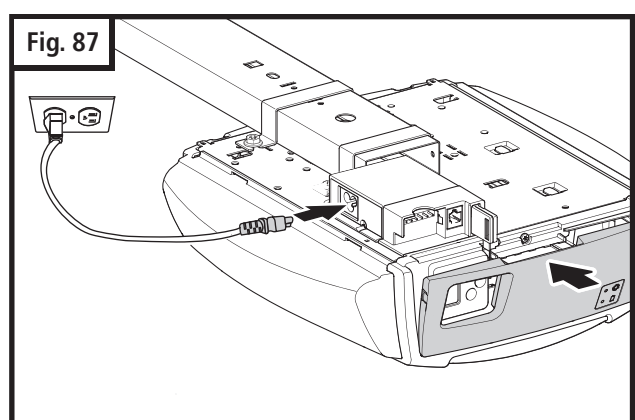
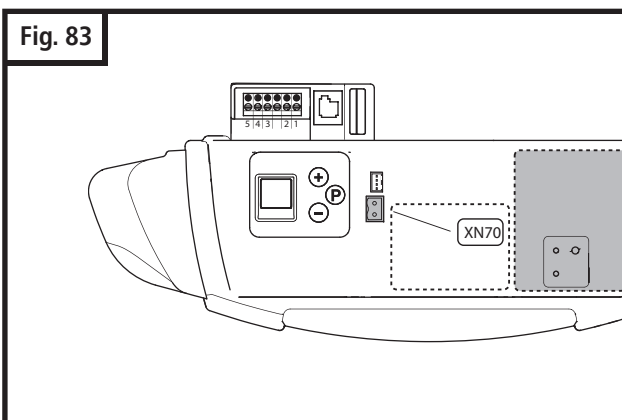
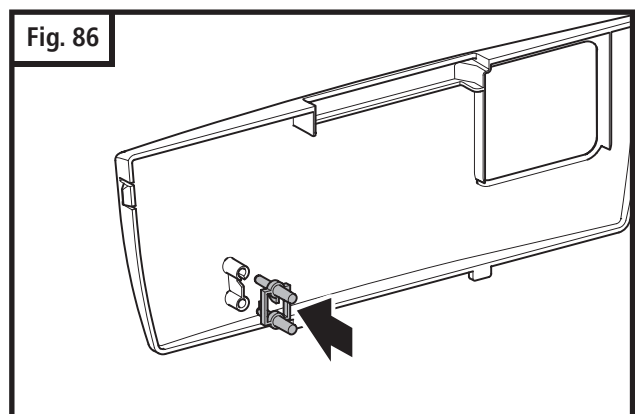
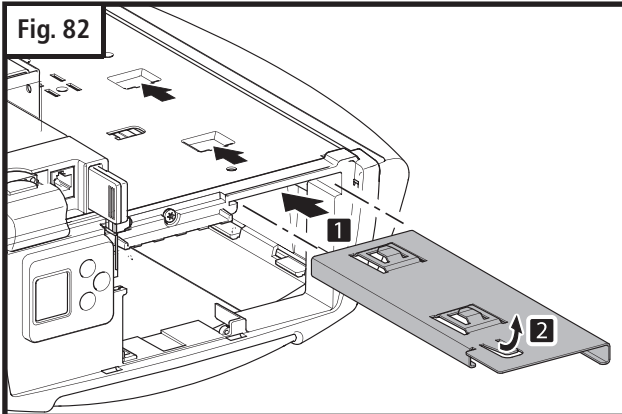
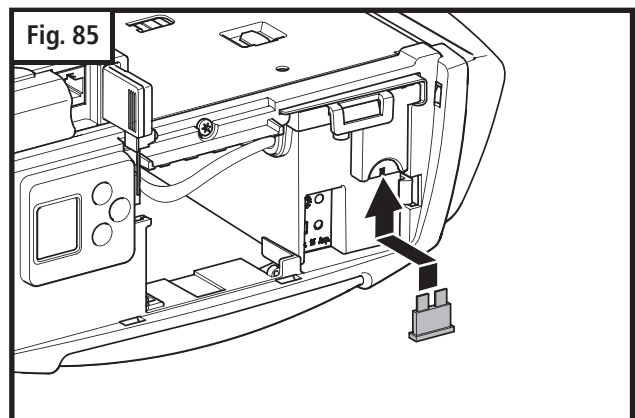
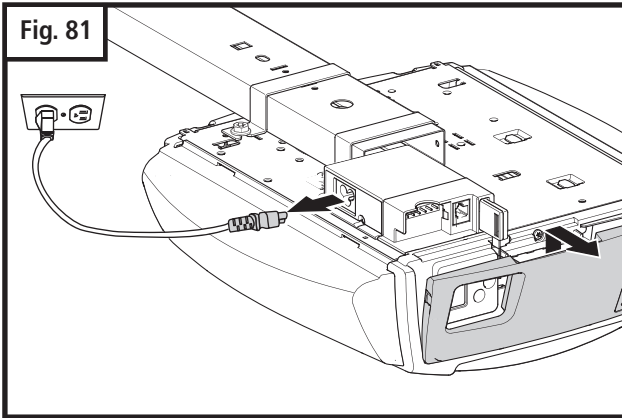
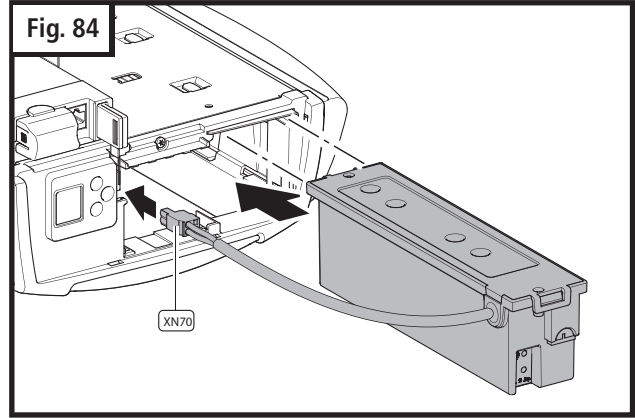
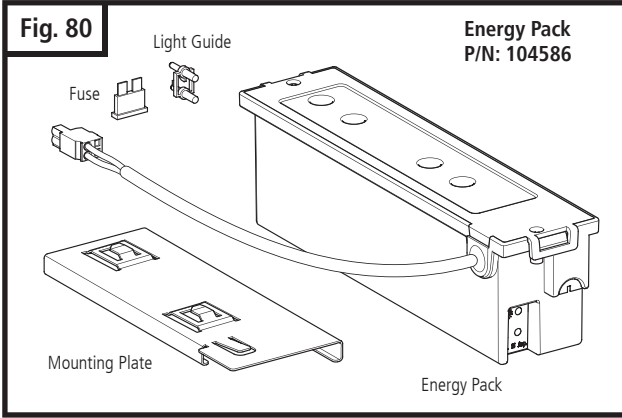

26-4. ENERGY PACK 100 (BATTERY BACKUP) (cont')

IMPORTANT:

Battery Normal Charge Condition

Upon connecting the new BBU Energy Pack 100 to the operator and connecting the operator to main power source as shown in Step 7. After 20 seconds the system will automatically recognize the connection and display a screen as shown in figure "A".

IMPORTANT:

Battery Low Charge Condition

In the event the operator does not recognize the connection, the steps in figure "B" must be performed to bring the BBU, Energy Pack 100, on-line with operator.

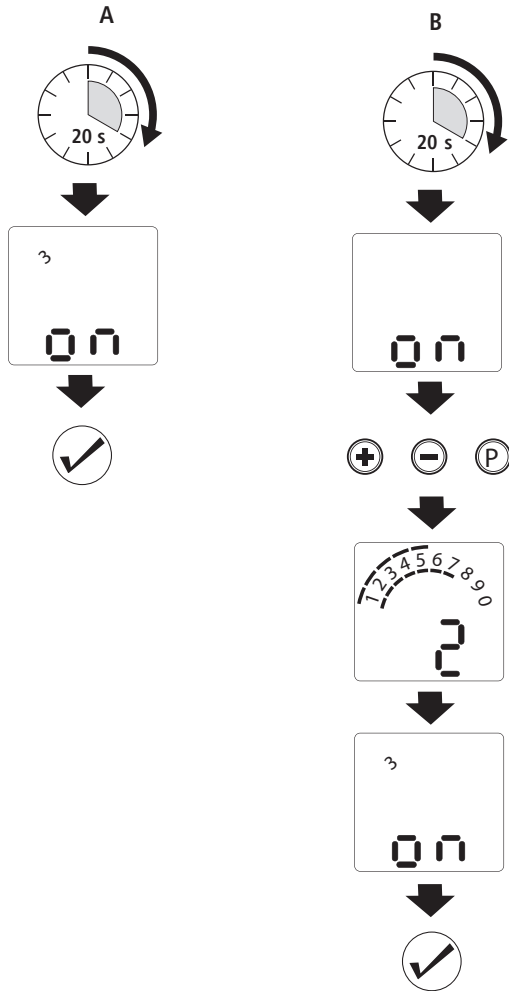

Instructions for figure "B"

1. Press and hold (P) button for 10 seconds.
2. Press and release (+) button until the dashes above the numbers cover 1-5
3. Press and release the (P) button once.
4. Press and release the (+) button until the dashes underscore 1-7.
5. Press and release (P) button once.
6. Press and release (+) button – Number 2 is blinking
7. Press and release (P) button once.
8. Press and hold (P) button until the word "on" is being displayed – Number 3 on the screen indicates that the BBU has been activated.

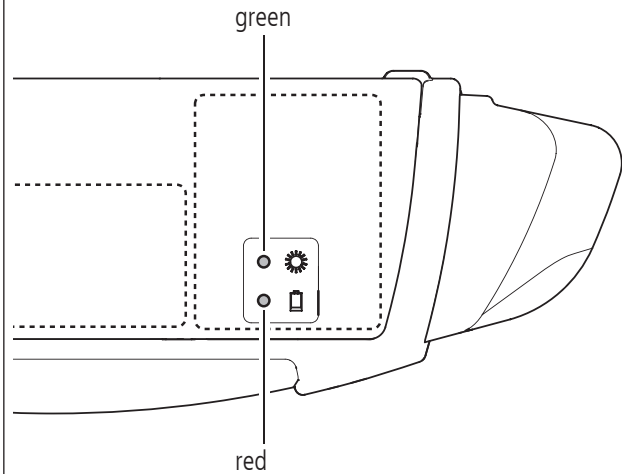

10.

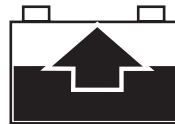

• Battery Charging

green

Note: New installation or after an electrical power outage requires 24 hours to fully charge



• All Systems are Normal Fully Charged

green

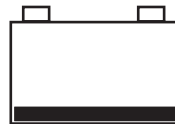

• Battery is Low

red

• Replace batteries if blinking red LED persists 24hrs after power is restored.

IMPORTANT:

The battery charges when the garage door operator is plugged into a working electrical outlet (it has power). Required charging time for a new installation or after an electrical power outage is 24 hours.

- To obtain maximum battery life and to prevent damage, disconnect the battery when the garage door operator is unplugged for an extended period of time.
- Energy Pack should be replaced every 1-2 years with normal use, under normal operating conditions.
- Replace fuse with Type Littlefuse Blade Fuse Series 257 rated 15 Amps, 32VDC ONLY (P/N 72280).

IMPORTANT INSTALLATION INSTRUCTIONS



TO REDUCE THE RISK OF SEVERE INJURY OR DEATH:

1. READ AND FOLLOW ALL WARNINGS AND INSTALLATION INSTRUCTIONS.
2. **The Automatic-Timer-To-Close (ATC) feature is only available with models Synergy 360, 370, 380.**
3. **DO NOT** enable the Automatic-Timer-To-Close (ATC) functionality if operating either one-piece or swinging garage doors. **Enable ONLY when operating a sectional garage door.**
4. Do not connect the operator to source of power until this manual instructs you to do so.
5. Place the Operating Warning Label next to the wall control panel in a prominent location. Affix Safety Label on inside of garage door.
6. **SAVE THESE INSTRUCTIONS** for future safety, adjustment, and maintenance purposes.

For Important Safety Instructions and Garage Door Operator Installation Instructions see pages 9 and 31.

IMPORTANT SAFETY INSTRUCTIONS



TO REDUCE THE RISK OF SEVERE INJURY OR DEATH:

1. READ AND FOLLOW ALL WARNINGS AND INSTRUCTIONS CAREFULLY.
2. **The Automatic-Timer-To-Close (ATC) feature is only available with models Synergy 360, 370, 380.**
3. **DO NOT** enable the Automatic-Timer-To-Close (ATC) functionality if operating either one-piece or swinging garage doors. **Enable ONLY when operating a sectional garage door.**
4. **Disconnect the electrical power to the garage door operator before making any repairs or removing the housing cover.**
5. Never let children operate or play with door controls. Keep the remote control away from children.
6. Always keep the moving door in sight and away from people and objects until it is completely closed. NO ONE SHOULD CROSS THE PATH OF THE MOVING DOOR.
7. **NEVER GO UNDER A STOPPED, PARTIALLY OPEN DOOR.**
8. **KEEP GARAGE DOORS PROPERLY BALANCED.** See Garage Door Owner's Manual. An improperly balanced door could cause severe injury or death. Have a qualified service person make repairs to cables, spring assemblies, and other hardware.
9. **SAVE THESE INSTRUCTIONS** for future safety, adjustment, and maintenance purposes.

For Important Safety Instructions and Garage Door Operator Installation Instructions see pages 9 and 31.

Installation Instructions:

- Disconnect power cord from operator.
- Remove back cover.
- Connect cable to power board.
- Slide board into housing.
- Slide module into GDO expansion module slot.
- Plug connector into operator's connector XW81.
- Replace back cover.
- Connect power cord to operator.
- Place ATC 100 operating Warning Label next to operator's Warning Label.

26-5. AUTOMATIC-TIMER-TO-CLOSE ATC 100 KIT (cont'd)

⚠ WARNING ⚠

To reduce the risk of FIRE or INJURY:

- Disconnect ALL electric and battery power BEFORE performing ANY service or maintenance.
- ATC is to be used **ONLY** with sectional garage doors.
- DO NOT enable the Automatic-Timer-To-Close (ATC) functionality if operating either one-piece or swinging garage doors.
- DO NOT enable ATC if operating a one-piece garage door.
- ALWAYS wear protective eye protection.

Automatic-Timer-To-Close (ATC) Installation Instructions
Available **ONLY** with models Synergy 360, 370, 380.

Fig. 88 ATC 100 Kit P/N: 105708

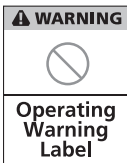
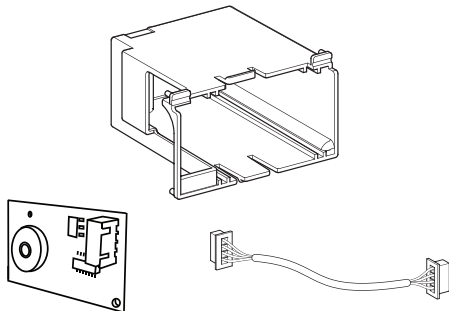

Fig. 89

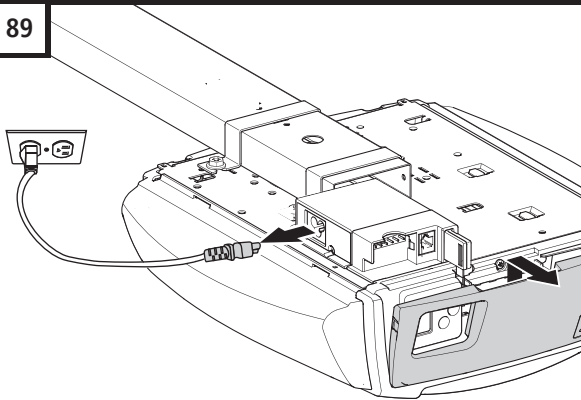

Fig. 90

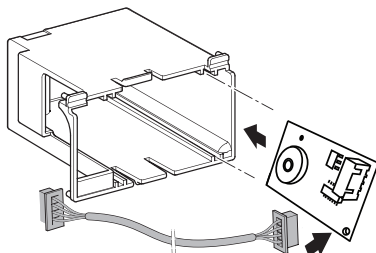

Fig. 91

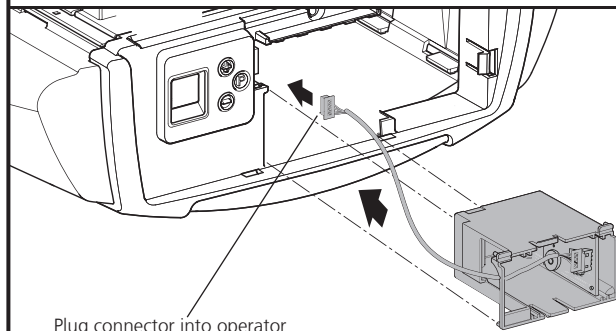
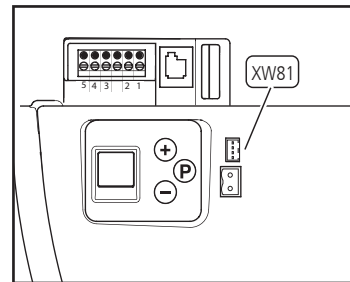
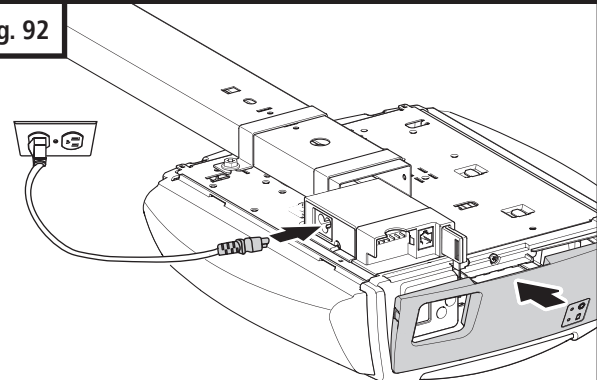

Fig. 92



26-5. AUTOMATIC-TIMER-TO-CLOSE ATC 100 KIT (cont'd)

IMPORTANT:

If the door encounters an obstruction while closing, the garage door operator will make a second attempt to close the door. If the obstruction has not been cleared after the second attempt, the garage door operator will reverse open, stop and WILL NOT close until the obstruction has been cleared. ATC will not work when the photo eye sensors are misaligned. This feature is NOT intended to be the primary method of closing the door.

Automatic-Timer-To-Close (ATC) Set-Up Instructions

The ATC will set automatically to close your garage door from the fully open position after 4 minutes.

The garage operator will **BEEP** and the lights will **FLASH** for approximately 10 seconds before closing the door.

To customize the door open time and warning phase from default settings above, follow the steps below:

Door Open Time

1. Press and hold **P** button for 10 seconds.
2. Press and release **+** button until the dashes above the numbers cover 1-3.
3. Press and release the **P** button once.
4. Press and release the **+** button until the dashes underscore 1-3.
5. Press and release the **P** button once.
6. Press and release the **+** button to scroll and select the door open time available from table below:

Door Open Times

Displayed Times on Operator	Time
10-50 Increments of 5 seconds	10-50 seconds
1.2	80 seconds
1.4	100 seconds
2.0	120 seconds
2.3	150 seconds
3.0	180 seconds
4.1*	250 seconds
9	9 minutes
1h	1 hour

Open Timer Screen Display

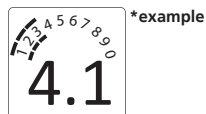

7. Once the open time is selected press and release **P** button once.

Warning Phase Time

1. Press and release the **P** button once.
2. Press and release the **+** button until the dashes underscore 1-4.
3. Press and release the **P** button once.
4. Press and release the **+** button to select the warning time available from the table below:

Warning Phase Times

Displayed Times on Operator	Time
5,10*-55 Increments of 5 seconds	5-55 seconds
1	60 seconds
1.1	65 seconds
1.2	70 seconds
1.3	80 seconds

Warning Phase Timer Screen Display

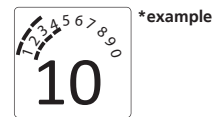

5. Once warning time is selected press and release the **P** button once.
6. Press and hold **P** button until the word "**On**" is being displayed.

Screen displayed when ATC is active and door reaches fully open position.

Open Timer



Warning Phase Active

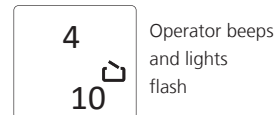

Deactivation of ATC

The ATC can be deactivated at any time provided it has been programmed. The ATC deactivation can be achieved by pressing and holding the wall control button with red LED for 6 seconds, the red LED in wall control button will flash indicating that the ATC feature has been deactivated momentarily.

Activation of ATC

Simply press the wall control button with flashing red LED firmly once, the timer-to-close (open time) will restart automatically.

26-6. EMERGENCY RELEASE SYSTEM

Model

304 - 700
304 - 1700
304 - 2500

Part#

46858
60798
76019

⚠ WARNING ⚠

Read and follow all warnings and installation instructions carefully as outlined in the operator manual. Failure to follow warning and instructions may result in severe injury or death.

Fig. 93

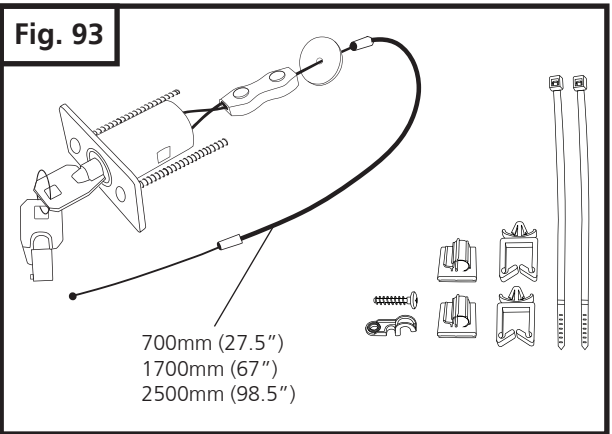

700mm (27.5")
1700mm (67")
2500mm (98.5")

Lock Installation

Fig. 94

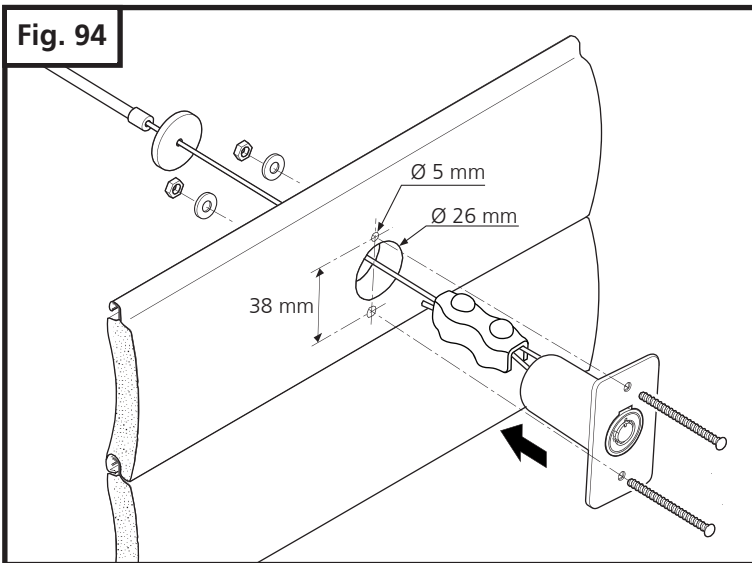

Locate mounting position for emergency release system lock. Mark and drill 5mm and 20mm holes per Fig. 94. Install and secure lock with hardware provided.

Emergency Release Cable Installation

Fig. 95

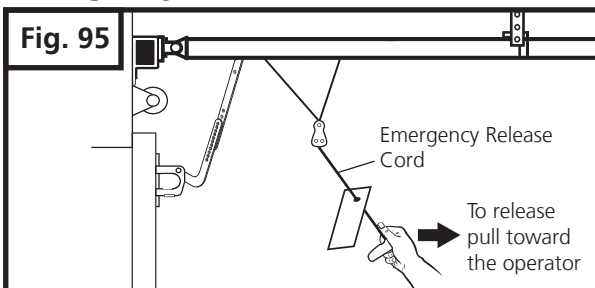

⚠ WARNING ⚠

To prevent possible serious injury or death from a falling door, make sure **"ONLY"** disengage door from trolley when garage door is in **"CLOSE"** position.

Unlock trolley by pulling Emergency release cord toward the operator as shown on Fig. 95.

Fig. 96

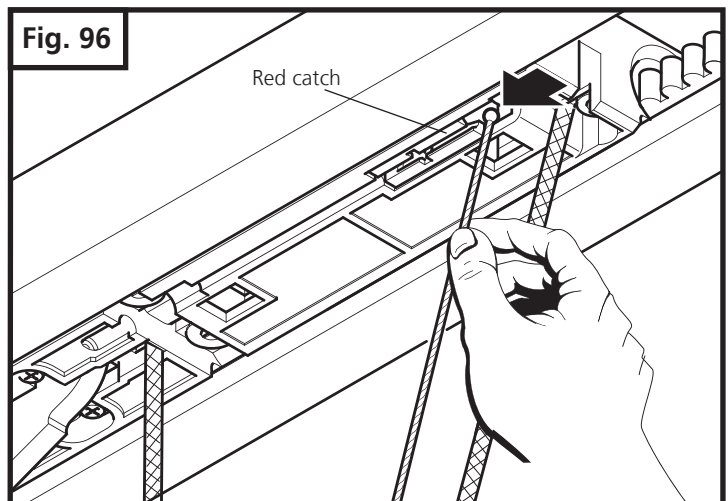

Insert cable in the trolley's red catch as shown on Fig. 96.

26-6. EMERGENCY RELEASE SYSTEM (cont'd)

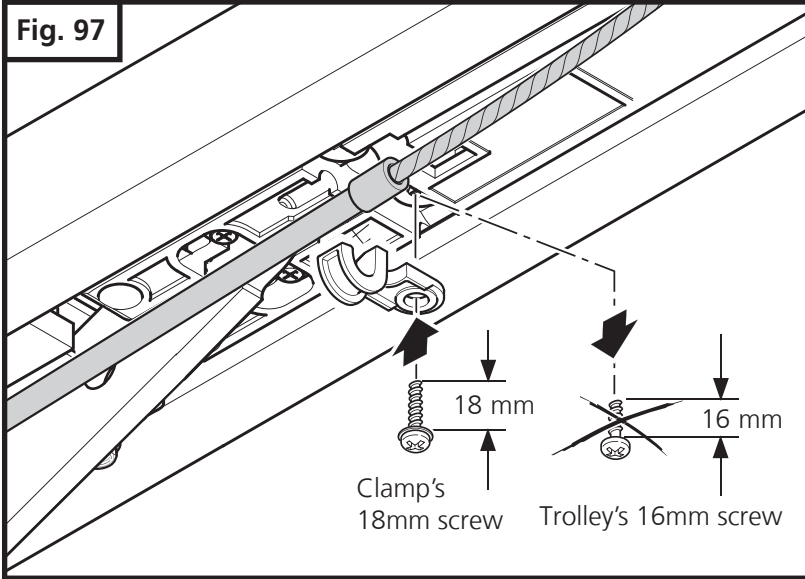

Install cable securement clamp (Fig. 97). Make sure to replace trolley's 16mm screw with 18mm screw provided with clamp.

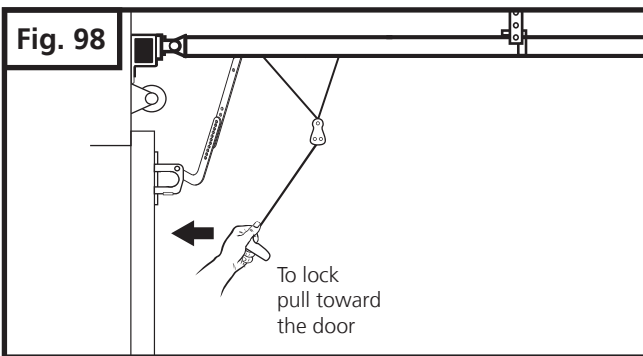

Lock trolley by pulling release cord toward the door (Fig. 98). Make sure trolley is engaged with belt connector.

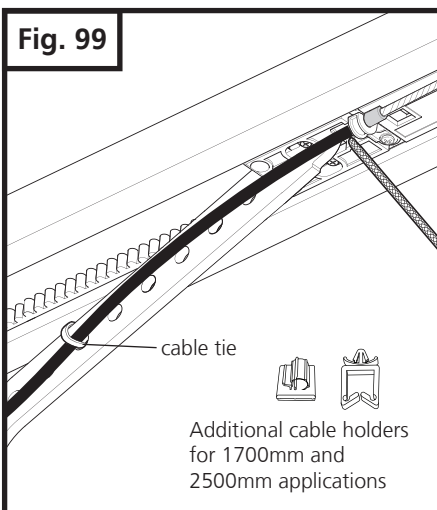

Secure cable with cable ties (Fig. 99).

27. TROUBLESHOOTING

The operator displays the system fault(s) automatically one at a time as follows:

System Fault Display: (Example - Error Code 7)

Fault 1



Note: ■ The last system fault code can be viewed by pressing the "P" button once.
To return to operation mode press "-" or "+" button.

FAULT DISPLAY	CODE	PROBLEM	SOLUTION
	7	NOTICE: ■ If no buttons are pressed within 120 seconds, the programming mode terminates automatically.	
	8	■ Adjustments setting interrupted before completion.	■ Door can be operated normally. Recheck adjustments if adjustment settings were not completed. Refer to page 18. ■ Have operator serviced *
	9	■ Rational speed (RPM) sensor impulse not present, operator system is obstructed.	■ Have operator serviced *
	10	■ The door does not move easily or is obstructed.	■ The maximum driving power has been set too low. Have maximum driving power checked by specialist *
	11	■ Excess travel stop.	■ Have operator serviced *
	15	■ Photo eye sensors not connected properly. ■ Photo eye sensors not aligned. ■ Obstruction in the door path (photo eye beam broken).	■ Check photo eye sensors wiring and connections. ■ Realign photo eye sensors. ■ Remove obstruction from door path.
	16	■ The current sensor for the monitoring motor overload is defective.	■ Have operator serviced *
	26	■ Power overload condition.	■ Have the outlet assigned for the operator and/or supplied power checked.
	28	■ Door movement too stiff or irregular. ■ Door blocked. ■ Operator operating sensitivity set too sensitive (low).	■ Check door for obstructions, proper manual operation, proper balance, or broken springs. Clear obstructions or have door serviced, if needed. ■ Have the operating sensitivity settings checked by an authorized dealer/installer.
	30	■ MS bus fault.	■ Reset the bus modules. ■ Have the connected bus modules checked.
	35	■ Electronic defect.	■ Have operator serviced.
	36	■ Wall control connected incorrectly.	■ Check wall control terminals connection. ■ Reset operator.

CAUTION



Short and rapid cycles are conducted with the operator (motor). This condition could result in overheating of motor / transformer.

28. MAINTENANCE AND ADJUSTMENTS

To ensure continued safe operation and extended life of your operator system, periodic checking for proper operation is necessary. Occasional maintenance and readjustment of your system may also be needed.

MONTHLY:

- Check reversal system by performing "safety reversal test" described in this manual.
- Check proper operation of door by manually moving door open and closed. If door binds or sticks, or is out of balance call for garage door service.
- Check and test photo eye safety system as described in this manual.

ONCE EVERY YEAR

- Keep door rollers, hinges, and bearings properly lubricated by following recommended door instructions or contacting a door service company in your area.

AS NEEDED:

- Readjust operator travel limits and force settings as necessary — due to cold weather, normal wear of door, etc. For any periodic adjustments needed refer to this manual.
- Check and readjust belt tension, if necessary, in the unlikely event that it loses its proper tension during the life of the operator. Always check the reversal system after any adjustment of travel limits or forces. A door operator that is not checked could possibly be out of adjustment and be dangerous.

29. LIMITED PARTS WARRANTY

MARANTEC AMERICA CORPORATION
Synergy Professional Series Residential Garage Door Opener System
Limited Parts Warranty
Synergy 360, 370, 380 Models

The Synergy 360, 370, 380 Systems Limited Warranty is 8 years for parts and a Limited Lifetime* Warranty for the motor, gear assembly and rail system.

Marantec America Corporation warrants:

LED Lighting System for 5 years

Battery Backup System (where applicable) and Accessories for 1 year.

THE LIMITED LIFETIME* PORTION OF THE WARRANTY IS FOR AS LONG AS THE ORIGINAL PURCHASER OF THE MARANTEC SYSTEM OWNS HIS OR HER HOME OR 20,000 SYSTEM OPEN & CLOSE CYCLES, WHICHEVER COMES FIRST.

Limited Warranty Coverage: THE LIMITED LIFETIME* WARRANTY IS FOR AS LONG AS THE ORIGINAL PURCHASER OF THE MARANTEC SYSTEM OWNS HIS OR HER HOME, OR 20,000 SYSTEM OPEN & CLOSE CYCLES, WHICHEVER COMES FIRST. This Warranty applies, upon purchase from a Marantec reseller and installation by a professional installer and registration of the product within 14 days of the date of installation of the product, (or within 30 days of closing on a new home from a developer) to any defect in materials or workmanship in the Marantec product parts or components from personal, normal, household use in compliance with the Owner's Manual for a period of 8 years from the date of installation (or closing date) on its parts and, for the Limited Lifetime* portion of this Warranty on the motor and rail system and belt, for as long as the original retail purchaser owns his or her home or 20,000 system open & close cycles, whichever comes first. Marantec warrants this Garage Door Opener system to its first retail, consumer purchaser only. This is not a commercial product. Marantec disclaims any and all warranties in the event that the product is obtained from a source which is not a Marantec authorized reseller or if the product is not installed by a professional installer. "Grey market" purchases are not warranted or recognized in any manner whatsoever. This is not a "do it yourself" product. There is no warranty if the seal on the Marantec carton is broken at the time of sale, delivery or installation by a professional installer. No "aftermarket" installation, alteration, opening of the housing or cases, modification or repairs are recognized or warranted. Any of the foregoing conduct voids all warranty provisions. This warranty is for parts only and is not for any service call(s) or labor in connection with the repair or replacement of the unit or its parts. Parts will only be shipped to a Marantec authorized reseller.

Marantec Accessories: Marantec accessories include such items as transmitters, wall controls, photo eye systems, and wireless/keyless entry systems. These are warranted to be free from defects in materials or workmanship for 1 year from the date of installation or closing. At Marantec's sole option, Marantec may elect to replace the accessory with new or reconditioned parts, components or units utilizing product of the same or similar design available at that given time. **WITH RESPECT TO ACCESSORIES, ALL OTHER WARRANTIES, INCLUDING FITNESS FOR PARTICULAR PURPOSE AND MERCHANTABILITY ARE SPECIFICALLY DISCLAIMED AND THE LIMITED WARRANTY SET FORTH BELOW IN BOLD TYPE IS HEREIN INCORPORATED BY REFERENCE.**

29. LIMITED PARTS WARRANTY (cont'd)

LED Lighting System and Battery Backup System: Marantec warrants the parts of the LED Lighting System, including its lighting bar, LEDs, and lens covers for 5 years and the Battery Backup System (where applicable) including its charging system and battery for 1 year from the date of installation or closing, if a new home purchased from a developer. These are warranted to be free from defects in materials or workmanship for 1 year from the date of installation or closing. At Marantec's sole option, Marantec may elect to replace the System with new or reconditioned parts, components or units utilizing product of the same or similar design available at that given time. **WITH RESPECT TO THE LED LIGHTING SYSTEM AND BATTERY BACKUP SYSTEM, ALL OTHER WARRANTIES, INCLUDING FITNESS FOR PARTICULAR PURPOSE AND MERCHANTABILITY ARE SPECIFICALLY DISCLAIMED AND THE LIMITED WARRANTY SET FORTH BELOW IN BOLD TYPE IS HEREIN INCORPORATED BY REFERENCE.**

Marantec does **not** warrant batteries (except the Battery Backup System battery above), sensors or LED bulbs (except the LED Lighting System LEDs above). Unauthorized repairs or repair parts, installations, commercial use, damage while in transit, defects or damage resulting from power washing, water or moisture exposure, or accidents, power failure and surges, resulting from alterations, lack of proper maintenance, unauthorized repair or modification of the product, opening of housing or case, misuse or abuse of the product, fire, flood, acts of God, damage to doors, tracks, springs, hardware or the residence, its contents and vehicles, other property or persons or other failures due to failure to follow the recommendations of the Owner's Manual are not warranted. This warranty applies only to Marantec systems purchased from authorized Marantec retail sellers and used in the United States, its Territories or Canada. Marantec make no warranties outside the United States, its Territories or Canada.

Marantec Commitment: If Marantec determines the product parts to be defective in materials or workmanship, then Marantec will supply parts for the repair or replacement of the defect to the Marantec authorized professional installer at no cost to you. You must pay for the service call and labor for installation of the part(s) determined to be defective by Marantec. At Marantec's sole option, Marantec may elect to replace the part(s) with new or reconditioned parts, components or units utilizing product of the same or similar design available at that given time.

THIS LIMITED WARRANTY IS IN LIEU OF ANY OTHER WARRANTIES, EXPRESS OR IMPLIED, INCLUDING ANY IMPLIED WARRANTIES OF MERCHANTABILITY OR FITNESS FOR A PARTICULAR PURPOSE, OR OTHER WARRANTIES IMPLIED BY STATUTE, AND OF ANY OTHER OBLIGATIONS OR LIABILITY ON THE PART OF MARANTEC AMERICA CORPORATION. THIS LIMITED WARRANTY DOES NOT COVER NON-DEFECT DAMAGE CAUSED BY IMPROPER INSTALLATION, OPERATION OR CARE AND MAINTENANCE, INCLUDING BUT NOT LIMITED TO ABUSE, MISUSE, POWER SURGE, FAILURE TO PROVIDE REASONABLE AND NECESSARY MAINTENANCE OR ANY ALTERATIONS TO THIS PRODUCT. LABOR CHARGES FOR DISMANTLING OR REINSTALLING A REPAIRED OR REPLACED UNIT ARE EXCLUDED.

UNDER NO CIRCUMSTANCES SHALL MARANTEC AMERICA CORPORATION BE LIABLE FOR CONSEQUENTIAL, INCIDENTAL OR SPECIAL DAMAGES ARISING IN CONNECTION WITH THE USE OR INABILITY TO USE THIS PRODUCT OR THE PREMISES IN WHICH IT IS UTILIZED. IN NO EVENT SHALL MARANTEC AMERICA CORPORATION INCUR LIABILITY FOR BREACH OF WARRANTY, BREACH OF CONTRACT, NEGLIGENCE OR STRICT LIABILITY IN EXCESS OF THE COST OF THE PRODUCT COVERED HEREBY. NO PERSON IS AUTHORIZED TO ASSUME, FOR MARANTEC AMERICA CORPORATION, ANY OTHER LIABILITY OR MAKE ANY MODIFICATIONS OR EXTENSIONS TO THE WARRANTY OF THIS PRODUCT. THIS LIMITED WARRANTY MAY NOT BE TRANSFERRED OR ASSIGNED.

30. WARRANTY LIMITATIONS, CLAIMS AND SERVICE:

This Limited Warranty is the one which Marantec gives on this product and sets forth all of its responsibilities regarding the Marantec product. There are no other express or implied warranties. Installation by unauthorized personnel or use of unauthorized parts or accessories could cause improper operation and even create dangerous conditions and voids all warranties. This could void the UL Safety Approval of the product and constitute a safety hazard.

This Limited Warranty contains the entire warranty on the product. All discussions, representations or negotiations between the consumer and the retail seller are merged into this Limited Warranty, and there are no understandings or warranties other than those herein. None of the terms of the Limited Warranty shall be waived or modified to any extent, except by a written instrument signed and delivered by Marantec's Corporate Officer.

This Limited Warranty is being delivered in Gurnee, Illinois, USA and is intended to be performed in the State of Illinois and shall be construed and enforced in accord with the laws and statutes of the State of Illinois without regard to or application of its rules on the conflict of laws, with the proper venue for any disputes being that of Marantec's registered office in Illinois or its corporate offices in Gurnee, Illinois, whichever Marantec elects. Marantec expressly disclaims the application to this Limited Warranty of the 1980 United Nations Convention on the International Sale of Goods. Any interpretation of this Limited Warranty shall be conducted in English and no other language. **ALL CLAIMS AND CAUSES OF ACTION OF ANY NATURE AGAINST MARANTEC AMERICA CORPORATION SHALL BE BROUGHT WITHIN 1 YEAR OF THE DATE OF DISCOVERY OF THE CLAIM.**

In the event any action or proceeding or claim is asserted or brought against Marantec, if Marantec prevails, then Marantec shall be entitled to recover all costs and expenses, including the actual fees of its attorneys and expert or professional witnesses incurred in connection with such action or proceeding or claim.

This Limited Warranty becomes valid only upon the receipt of "Payment in Full" by Marantec from the Marantec reseller and upon receipt of "Payment in Full" by the Marantec reseller from the end user. This Limited Warranty is null and void if the System is not installed within 24 months of the date of manufacture as marked on the product housing. This Limited Warranty is void outside the United States, its Territories and Canada.

Whenever possible, each provision of this Limited Warranty shall be interpreted in such a manner as to be effective and valid under applicable Illinois law. If any provisions of this Limited Warranty are prohibited or invalidated under applicable law, then such provisions shall only be ineffective to the extent of such prohibition or invalidity, without invalidating the remaining provisions of this Limited Warranty.

Some jurisdictions do not allow the exclusion or limitation of consequential, incidental or special damages, so the above limitations or exclusions may not apply to you. This Limited Warranty gives you specific legal rights and you may also have other rights which vary from state to state.

31. REGISTRATION

This Warranty becomes effective upon registration at the Marantec web site: www.marantec.com. If you do not have access to the internet, please fill out and send in enclosed warranty card.



***HOW TO ORDER
REPAIR PARTS***

DEVANCO CANADA

19192 HAY ROAD, UNIT Q
SUMMERSTOWN, ON K0C 2E0

TOLL FREE: 855-931-3334

www.devancocanada.com

**WHEN ORDERING REPAIR PARTS
PLEASE SUPPLY THE
FOLLOWING INFORMATION:**

- ✓ PART NUMBER
- ✓ DESCRIPTION
- ✓ MODEL NUMBER