

1A3982 Operator Cover ASSEMBLY

CARTON INVENTORY	
Description	QTY
COVER END	2
COVER SIDE	2
COVER TOP	1
RTV SILICONE SEALANT (3 OZ.)	2
SCREW #8 X 3/8"	30
INSTRUCTIONS	1

1. Apply a 1/8" diameter bead of silicone sealant onto both flanges of each cover end.
2. Assemble ends to cover sides with screws. Do not tighten screws until Step 5.
3. Place cover top on the floor with flanges facing up. Apply a 1/4" diameter bead of silicone sealant to all four inside corners of top.
4. Invert top and position over assembled cover ends and sides. Fasten top with screws.
5. Tighten all screws.

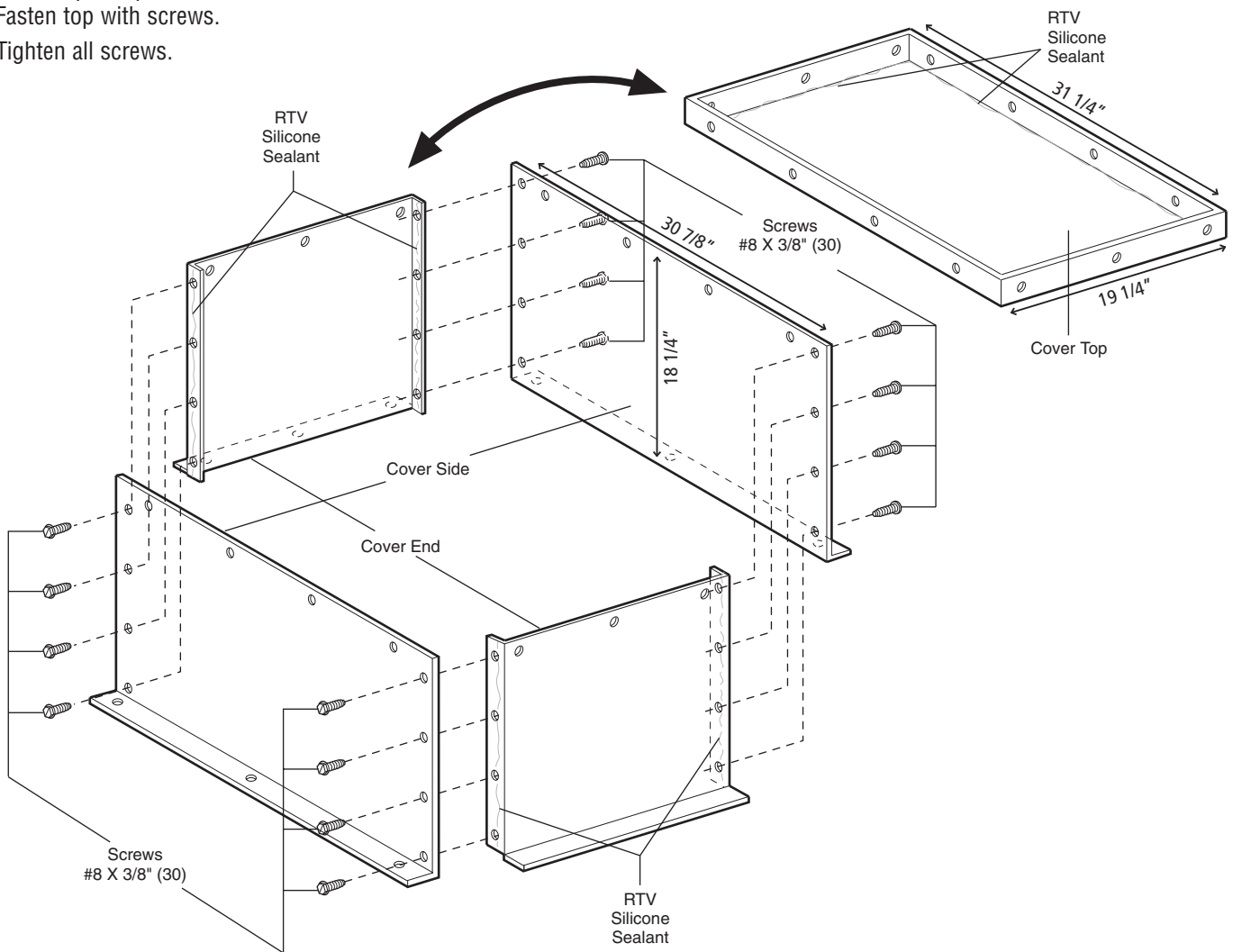

For more information, please visit www.devancocanada.com or call toll free at 855-931-3334