

SLIDING GATE OPERATOR

MODEL

BCSI

TECHNICAL MANUAL
INSTALLATION AND MAINTENANCE

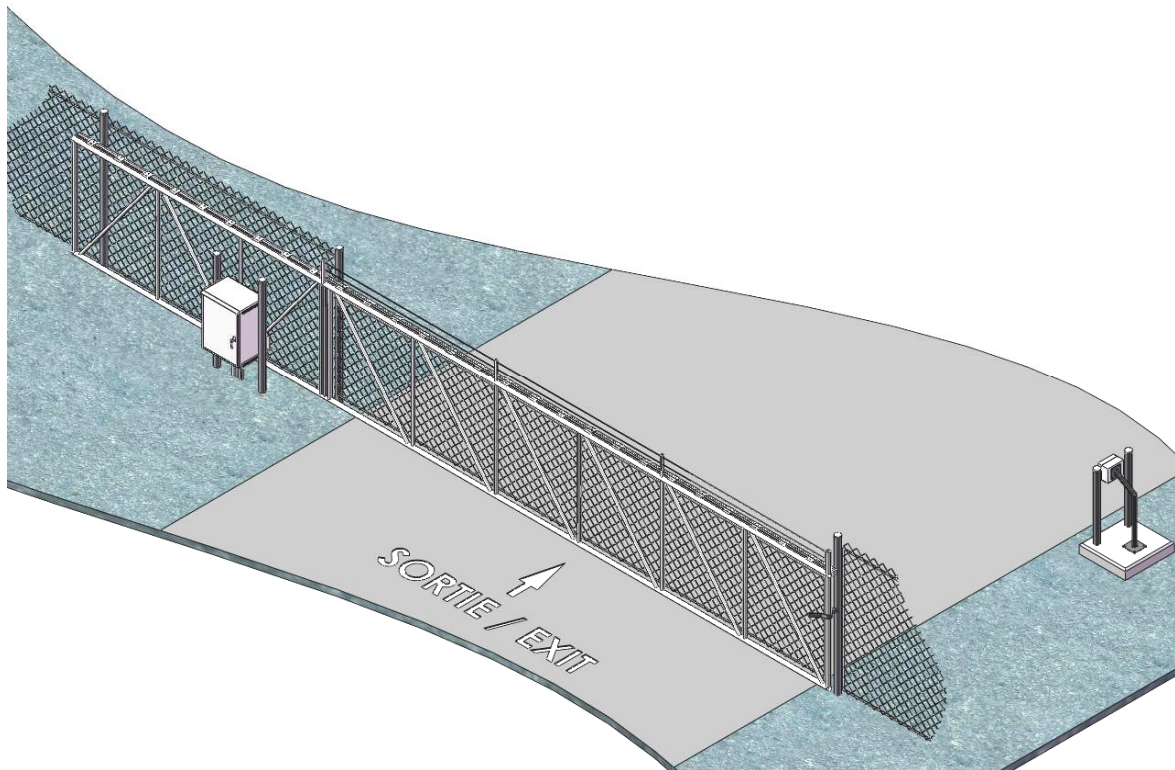

BCSI

Gate system with BCSI sliding gate operator

**For more information, please visit www.devancocanada.com
or call toll free at 855-931-3334**



IMPORTANT SAFETY INSTRUCTIONS

WARNING – TO REDUCE THE RISK OF SEVERE INJURY OR DEATH:

All technicians having to install, maintenance and repair, must read these safety instructions about sliding gate-system¹ with BCSI operator.

Any intervention on the gate-system should only be done by ***qualified technicians*** having proper knowledge for that kind of work and appropriate equipment and tools to work safely.

Any negligence during an intervention could cause severe injury or death. As soon as you open the cabinet, cut power down by switching the disconnecting switch (red button) to “OFF” - see section “2.5 – Shutting down the equipment“.

Do not proceed with installation of this gate operator if:

- 1) The model class of this gate isn't appropriate for your installation, following model classes defined by UL 325.
- 2) All exposed pinch points are not eliminated or guarded.
- 3) Guarding is supplied for exposed rollers.

The gate operator is the main component of your system. It mainly consists of an electrical motor, a reducer and various mechanical parts, enabling the gate to open and close. There is also, inside the cabinet, a control panel interfaced with various control and security features.

The gate is the moving part of your installation.

When moving, the gate represents a high risk of injuries if not correctly used.

All sliding gates must be equipped, according to their use, with appropriate safety features for safe operations. You must communicate with us to know the rules to follow in case of special installation.

This gate is intended only for vehicles. Pedestrians must be supplied with a separate access opening. The pedestrian access opening shall be designed to promote pedestrian usage. Locate the gate such that persons will not come in contact with the vehicular gate during the entire path of travel of the vehicular gate.

¹ By “gate-system”, we represent the whole installation including the gate, the operator, the control panel, the access system and any other auxiliary equipment related to site secure.

The sliding gate can cause severe injuries or even death.
It is strictly forbidden to allow pedestrians to walk through the gate.

The gate must be installed in a location so that enough clearance is supplied between the gate and adjacent structures when opening and closing to reduce the risk of entrapment.

The gate must be properly installed and work freely in both directions prior to the installation of the gate operator. Do not over-tighten the operator clutch (by screwing bolts) to compensate for a damaged gate.

Controls intended for user activation must be located at least six feet (6') away from any moving part of the gate and where the user is prevented from reaching over, under, around or through the gate to operate the controls. Outdoor or easily accessible controls shall have a security feature to prevent unauthorized use.

The Stop and/or Reset button must be located in the line-of-sight of the gate. Activation of the reset control shall not cause the operator to start.

A minimum of two (2) WARNING SIGNS shall be installed, one on each side of the gate where easily visible.

One or more contact sensors shall be located where the risk of entrapment or obstruction exists.

Warning signals showing risk of injuries that can be cause by a rising gate must be installed.

Never let children operate gate controls or play close to the gate, even under adult supervision.

Intervention site

Any technician having to work on a gate-system must establish a safety perimeter around the electrical rising gate with yellow or red safety ribbon. Orange cones can also be use to establish a safe work area.

Plan a way to divert traffic while working on the gate-system. If that's impossible, be sure to put proper signalisation for drivers traveling near the gate area.

Electrical and mechanical security

Lock down the gates power lines while working on the gate-system. Follow all local rules.

Follow all mechanical safety rules in each gate's technical manual.

GATE CLASS

Following UL 325 definitions above, the sliding gate operator BCSI is intended for use in class III and IV.

RESIDENTIAL VEHICULAR GATE OPERATOR – CLASS I – A vehicular gate operator (or system) intended for use in a home of one-to four single family dwelling, or a garage or parking area associated therewith.

COMMERCIAL/GENERAL ACCESS VEHICULAR GATE OPERATOR – CLASS II – A vehicular gate operator (or system) intended for use in a commercial location or building such as a multi-family housing unit (five or more single family units), hotel, garages, retail store, or other building servicing the general public.

INDUSTRIAL/LIMITED ACCESS VEHICULAR GATE OPERATOR – CLASS III – A vehicular gate operator (or system) intended for use in an industrial location or building such as a factory or loading dock area or other locations not intended to service the general public.

RESTRICTED ACCESS VEHICULAR GATE OPERATOR – CLASS IV – A vehicular gate operator (or system) intended for use in a guarded industrial location or building such as an airport security area or other restricted access locations not servicing the general public, in which unauthorized access is prevented via supervision by security personnel.

TABLE OF CONTENTS

1. INTRODUCTION	7
2. GENERAL POINTS	8
2.2 General view of gate operator.....	9
2.3 General view of moving part of the sliding gate:	12
2.5 Shutting down the equipment	13
2.6 Manual operation of the gate	14
3. INSTALLATION PROCEDURE	15
3.1 Gate operator installation.....	16
3.2 Main chain adjustment.....	18
3.3 Limit switches adjustments:	19
3.4 Torque limiter adjustment	20
3.5 Disengaging mechanism.....	21
3.6 Photocell beam wiring.....	22
3.7 Safety edges wiring	22
3.8 Placards installation.....	23
3.9 Electrical wirings	23
4. MAINTENANCE MANUAL	24
5. INSPECTION REPORT.....	26

1. INTRODUCTION

BCSI gates are listed by Intertek ETL following standard UL325 5th Edition, October 8th 2009 and CSA 22.2 No. 247-92 (R2008).

Warranty on the BCSI gate operator

The BCSI sliding gate operator, including auxiliary equipment, supplied or supplied and installed by our company is guaranteed for a one year period from the invoicing date or from the date of the installation should this date differs. This warranty is offered for usage under normal conditions.

Inspection and maintenance required

A visual inspection of the components must be done periodically to verify the good functioning and to perform the maintenance required as per the maintenance guide of the operator, all this to insure the validity of the warranty.

Any neglect of maintenance that will be evident during a breakage or any damage caused by any accident to the operator will cancel the guarantee.

Are not included in the warranty

- Breakage, vandalism or accidents caused to the operators;
- Problems caused by snow or ice;
- Readjustments to the loop detector;
- Power supply problems to the operators (breakers, fuses, etc.);
- Service calls caused by customer's auxiliary systems.

2. GENERAL POINTS

2.1 General view of a gate system (example):

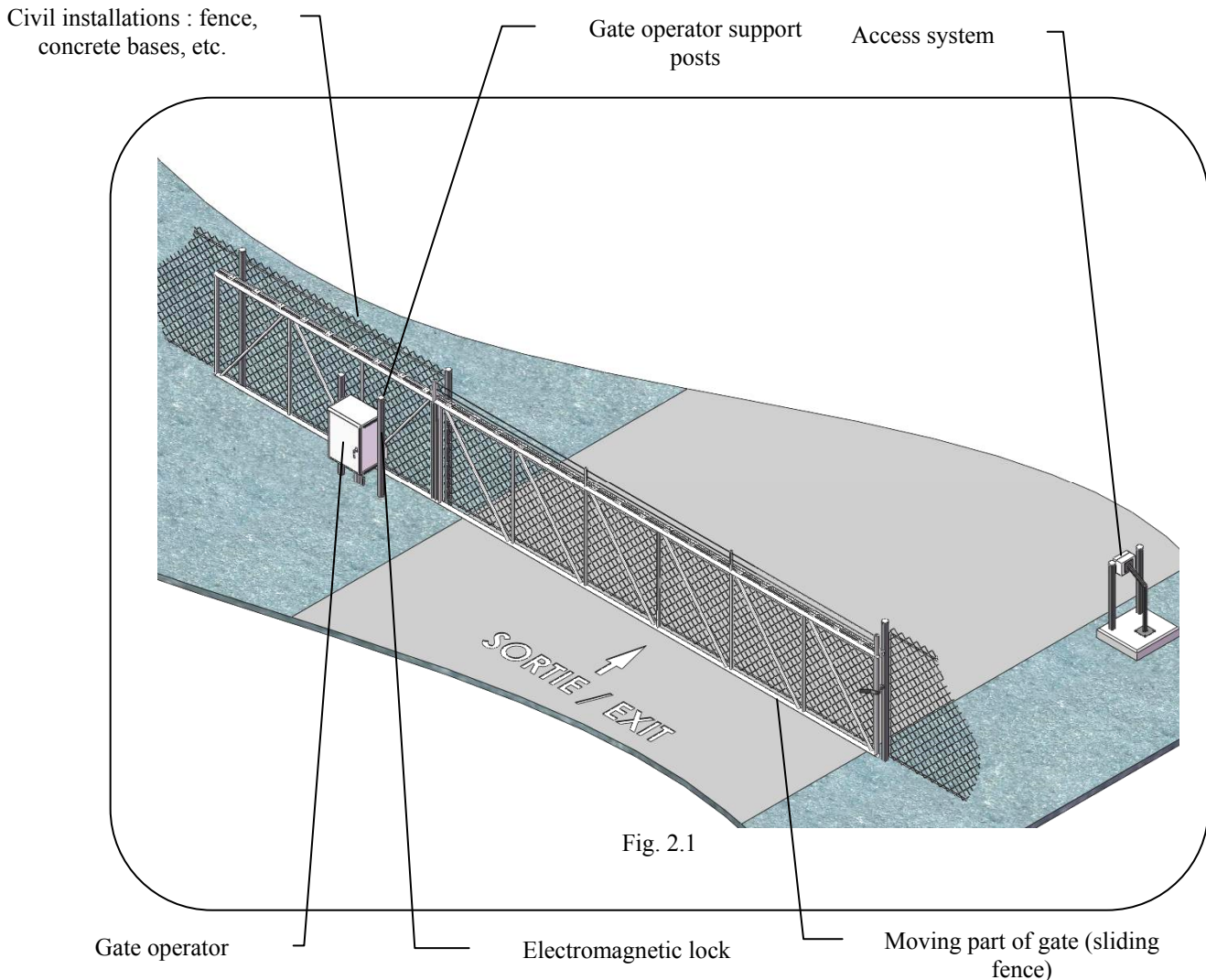

The sliding gate operator, model BCSI, is designed for vehicular access control in commercial and industrial areas.

Advantages:

- Completely secures the site;
- Short operation cycle (speed of 1 foot/second);
- Heavy duty mechanism;
- Low operating costs and maintenance;
- Customized design of the aluminum fence frame;
- Standard safety edges;
- Manual opening device.

2.2 General view of gate operator:

Cabinet (Fig. 2.2.1):

The cabinet, built in aluminum 1/8" (3,2 mm) thick, has an entirely welded gutter making the cabinet a weather proof one of NEMA 3R type. The door has a sealing gasket, a high security handle with door lock and a stainless steel strap hinge. The aluminum control box is located inside the cabinet and included all necessary electrical components for operating the gate.

Mechanics (Fig. 2.2.2):

A worm gear reducer, ratio 40:1, with a "C" flange for motor installation, allows a speed of 12 inches/second when assembled to a standard motor with 1750 rpm. Available on request, the operator "BCSI-HV", equipped with a frequency drive, allows a speed up to 24 inches/second.

A torque limiter of 4½" diameter, adjustable up to 2,800 pounds of pressure, is installed directly on reducer output shaft. The torque limiter is made of a gear of ratio 50:26 with two friction disks mounted on a ball bearing and tightened by a spring washer and a nut. This nut allows adjustments of the required force according to the weight of the gate. The link between the operator and the gate is made of the main shaft, two secondary shafts and a #50 gauge chain. The shafts have a 1" diameter and are all mounted on ball bearings that can be lubricate at need according to frequency of operations.

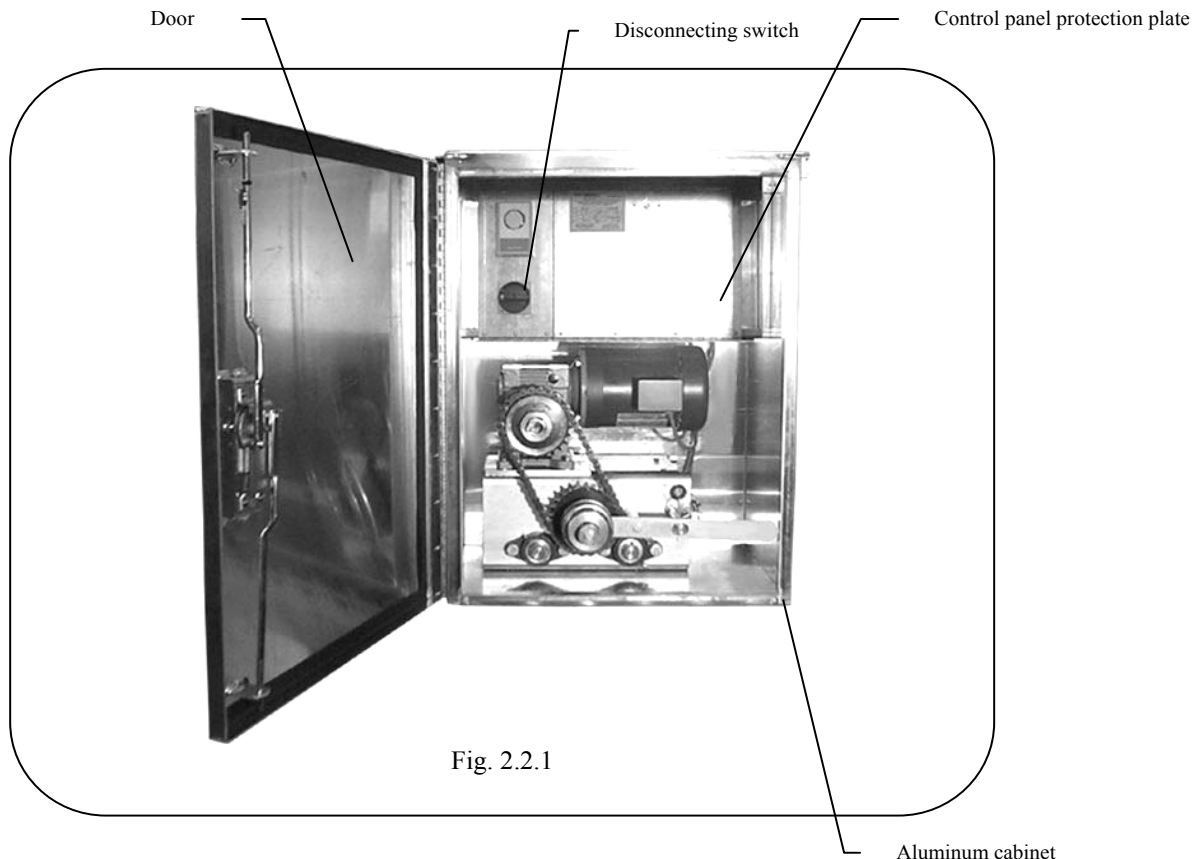

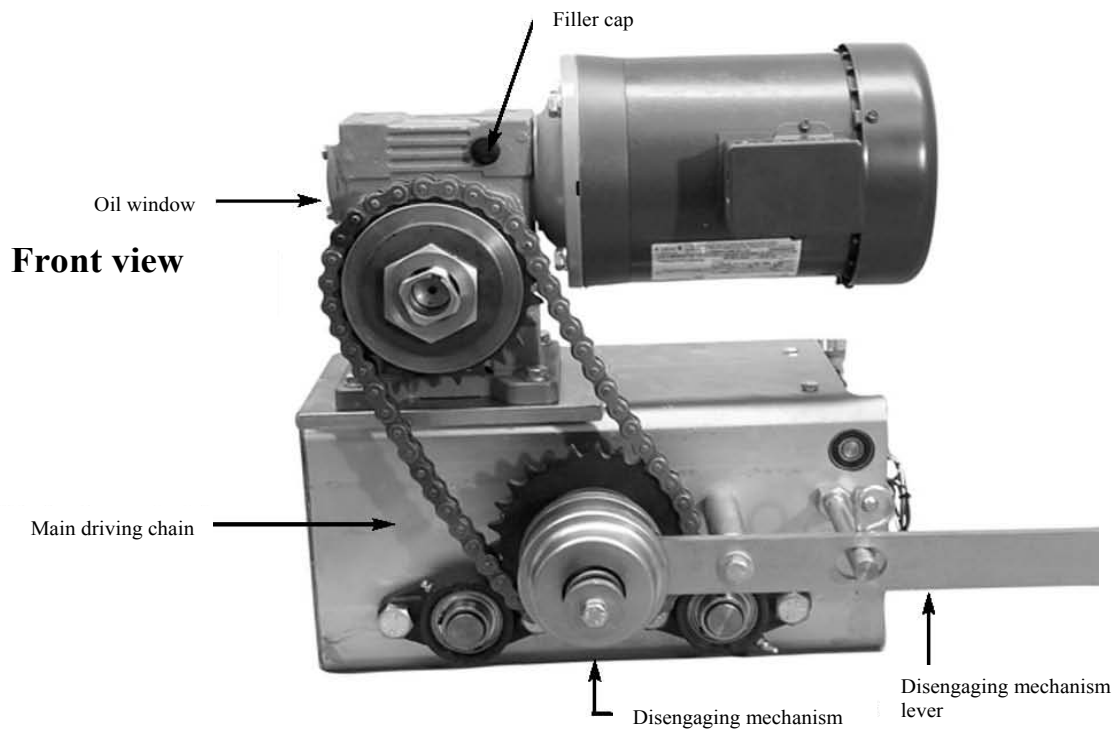
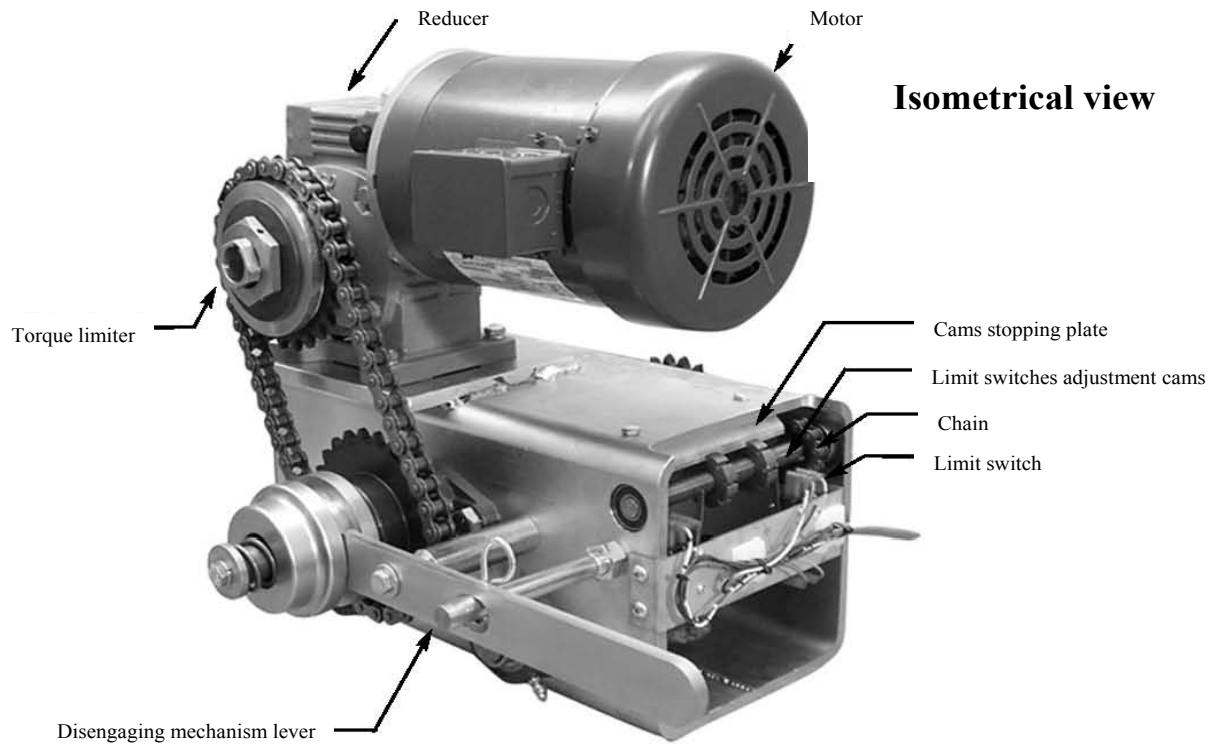

Fig. 2.2.2

Control panel:

A programmable logic controller (PLC) analyses the information and controls the gate operations. When in automatic operating mode, the PLC closes the gate after a delay ranging from 0 to 60 seconds, delay that can be set by an adjustable timer. A second timer stops the gate after the maximum opening/closing movement time is reached.

The opening and closing paths are controlled by quick action limit switches. They are activated by cams on worm gears mounted on ball bearings.

The BCSI sliding gate operator can be equipped with different motors depending on the available electrical power supply on site. The motor's power can vary according to the gate's dimensions. See nameplate for details.

A 150 watts heating element controlled by thermostat keeps the temperature steady inside the cabinet.

The gate can be activated by push-buttons, remote control, keypad, card reader or any other similar device. Also, all security devices like safety edges, loops and photoelectric cells can be connected to the control panel.

Auxiliary devices:

- Push button control;
- Remote control;
- Access keyboard;
- Card reader;
- Loop detector;
- Safety system.

To reverse motor direction:

To have the operator open to the left

Power off and remove the jumper wire from terminals 5 & 6, add a jumper between terminals 5 & 7, power up for 10 seconds, power off and put the jumper back on terminals 5 & 6. Power up and the operator should open to the left.

To have the operator open to the right

Power off and remove the jumper wire from terminals 5 & 6, add a jumper between terminals 5 & 8, power up for 10 seconds, power off and put the jumper back on terminals 5 & 6. Power up and the operator should open to the right.

2.3 General view of moving part of the sliding gate:

Chain-link fence gate:

The gate, used with a BCSI operator, is an assembly of the frame, the chain-link fence, the rails and a safety edge required for compliance with UL 325. The gate frame is a welded structure made of standard galvanized steel profiles and enforcements except the rails which are in aluminum.

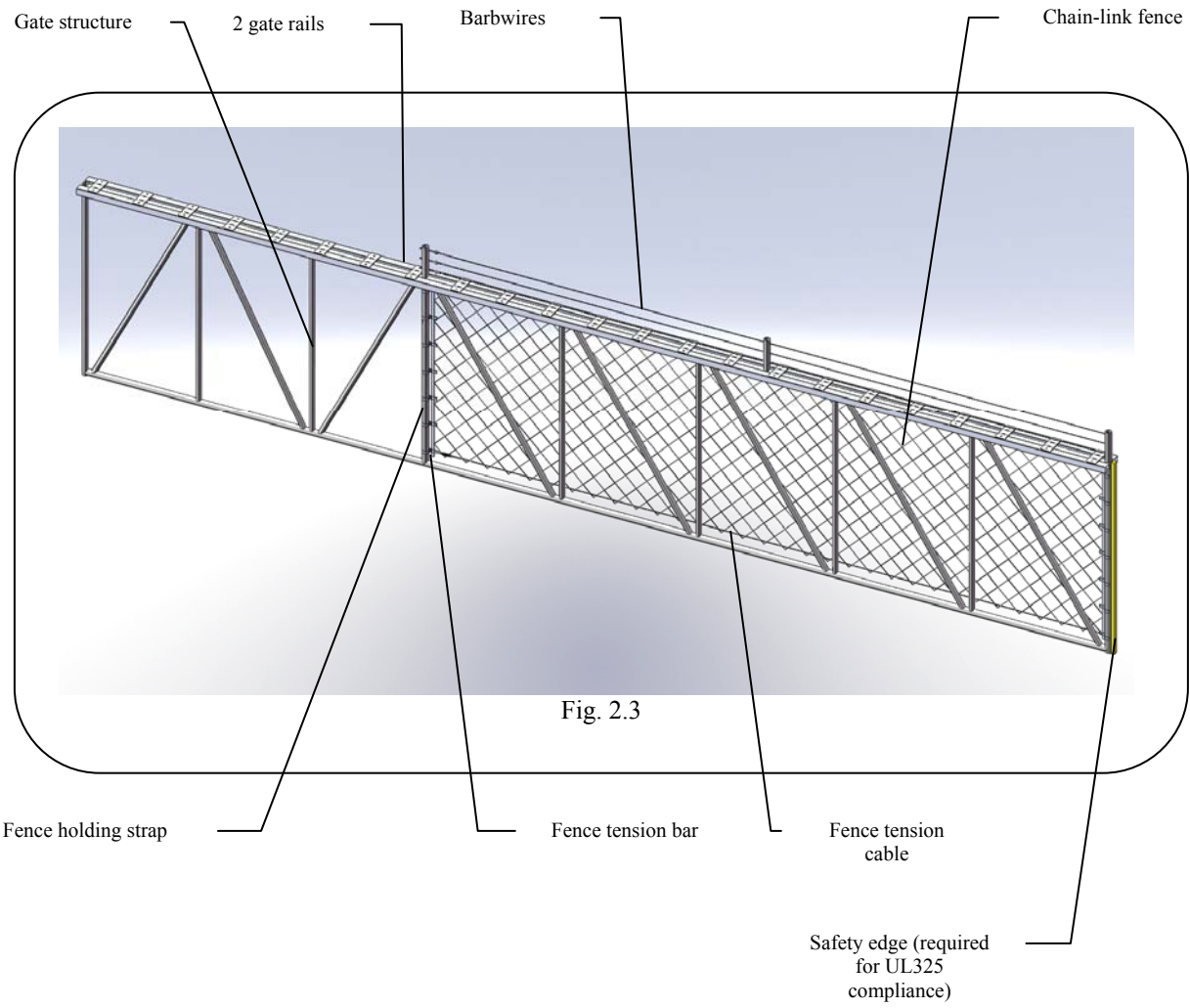

2.4 General conditions of operation:

The sliding gate operator BCSI is equipped, inside the cabinet, with a heating element to insure proper functioning in all type of climatic environments, ranging from -40°C to +50°C.

2.5 Shutting down the equipment:

As soon as you open the door, you must shut down power by activating the disconnecting switch (red button) to the "OFF" position. - see Fig.2.5.

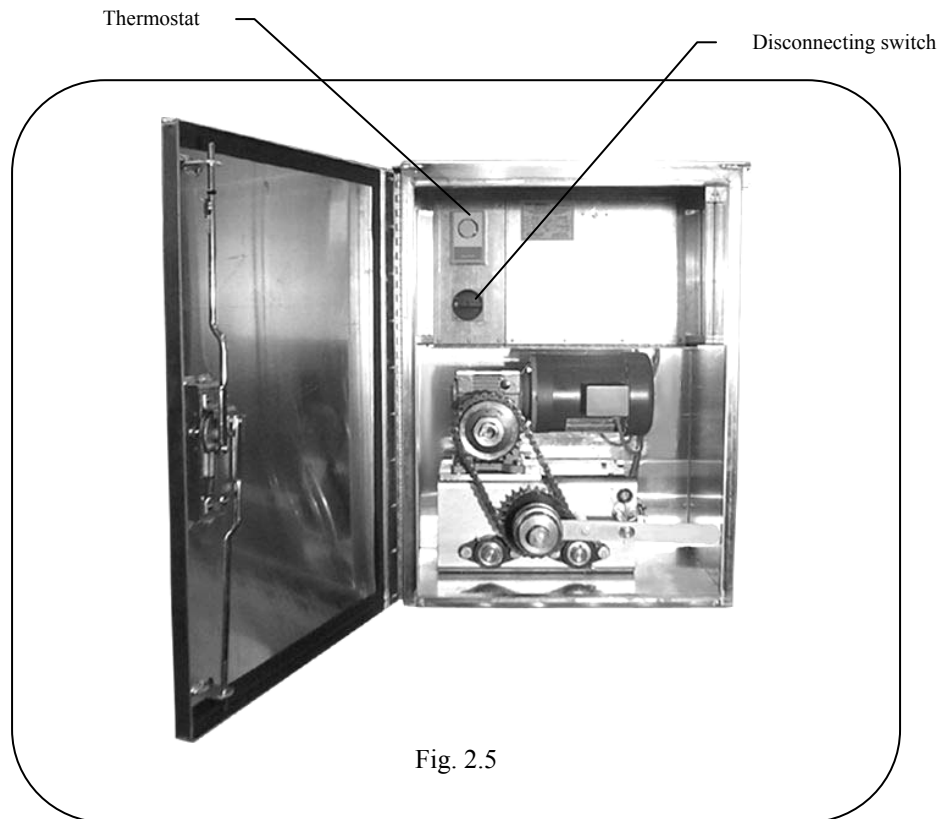

Fig. 2.5

2.6 Manual operation of the gate:

Opening or closing the gate in case of power failure:

A disengaging mechanism allows manual closing or opening of the gate in case of power failure. Disengaging the mechanism won't affect the limit switches. You only have to remove the dowel pin, push on the plate and reinsert the dowel pin to disengage the mechanism, as shown on Fig 2.6. When manual operations are over, remove the dowel pin again, pull on the plate and put back the dowel pin to reengage the mechanism.

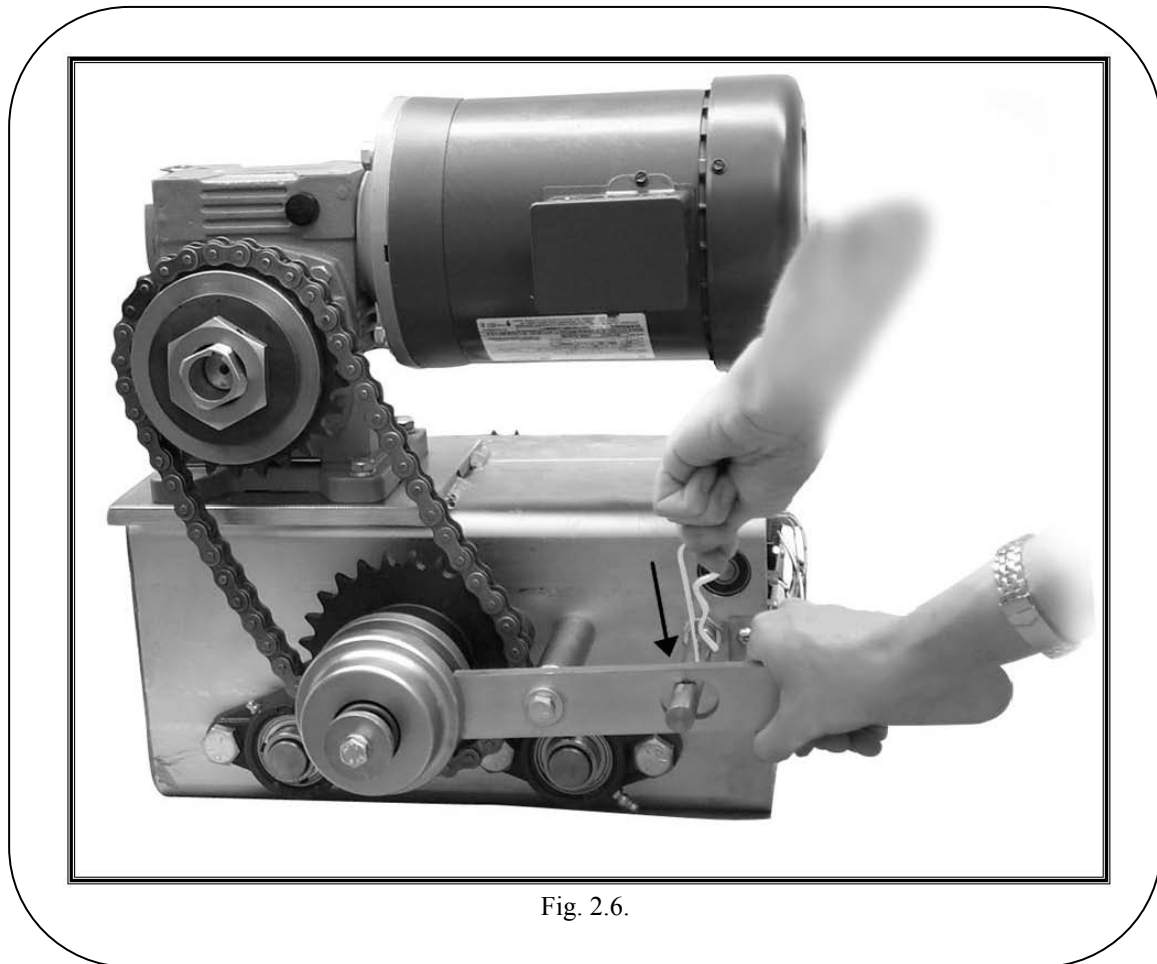

Fig. 2.6.

3. INSTALLATION PROCEDURE

(for qualified technicians only) :



IMPORTANT INSTALLATION INSTRUCTIONS

WARNING – TO REDUCE THE RISK OF SEVERE INJURY OR DEATH:

- 1) READ AND FOLLOW ALL INSTALLATION INSTRUCTIONS
- 2) Install only on a properly operating and balanced gate. A gate that is operating improperly could cause severe injury. Have qualified service personnel make repairs to cables, spring assemblies, and other hardware before installing the operator.
- 3) Remove all pull ropes and remove, or make inoperative, all locks (unless mechanically and/or electrically interlocked to the power unit) that are connected to the gate before installing the operator.
- 4) Do not connect the gate operator to the source of power until instructed to do so.
- 5) Locate the station control: (a) within sight door, (b) at a minimum height of 5 feet so small children cannot reach it, and (c) away from all moving parts of the door.
- 6) Install the Entrapment Warning Placard next to the control station in a prominent location.
- 7) For products having a manual release, instruct the end user on the operation of the manual release.

3.1 Gate operator installation:

The operator, model BCSI, is installed between two galvanized steel posts of 3½" diameter with two separate concrete bases (Fig. 3.1.1) or on a prefabricated concrete base (Fig. 3.1.2). The operator is attached to the posts with straps and spring jam nuts (Fig. 3.1.1). On request, the operator can be supplied with a steel base to allow installation on an existing concrete base (Fig. 3.1.3). The distance between the two posts must be of 25¾". The minimal post height above the base top must be of 60 inches. It is recommended to install the posts deep enough to avoid movement of posts in winter conditions.

We recommend the installation of the metal support, supplied with the operator, at 18 inches above the ground, just under the operator, to ease its installation. When the operator is installed, attach the two metal supports that hold the traction chain to the gate. These two supports must be fixed at the same height of the secondary shafts gear at the back of the operator. Proceed then to the alignment of the chain so that it is parallel to the gate and well engaged in the gears. Mark the support at the spot where the chain must be attached and drill a 3/8" diameter hole on each support. Install the chain as recommended. (See drawing BCSI-3D-EXT and section 3.2).

Do all electrical connections for power and required controls, according to selected functions. Before you power on the operator, it is strongly recommended to disengage the mechanism in order to verify the direction of rotation of the motor (see section 3.5). Wrong direction of rotation could seriously damage your installation. To change the direction of rotation, look at the electrical wirings of the electrical power supply phases. If the direction of rotation is wrong, correct it before doing any adjustments on the limit switches (see section 3.3) and the torque limiter (see section 3.4). After these final adjustments, the operator is ready for commissioning.

Regular maintenance, as mentioned in section 4, is required in order to keep your operator in proper operation conditions.

Do not install this operator if all openings of the gate are not guarded or screened from the bottom of the gate to a minimum of 4 feet (1.22 m) above the ground to prevent a 2-1/4 inch (57.2 mm) diameter sphere from passing through the openings anywhere in the gate, and in that portion of the adjacent fence that the gate covers in the open position. The two (2) WARNING SIGNS shall be installed, one on each side of the gate where easily visible.

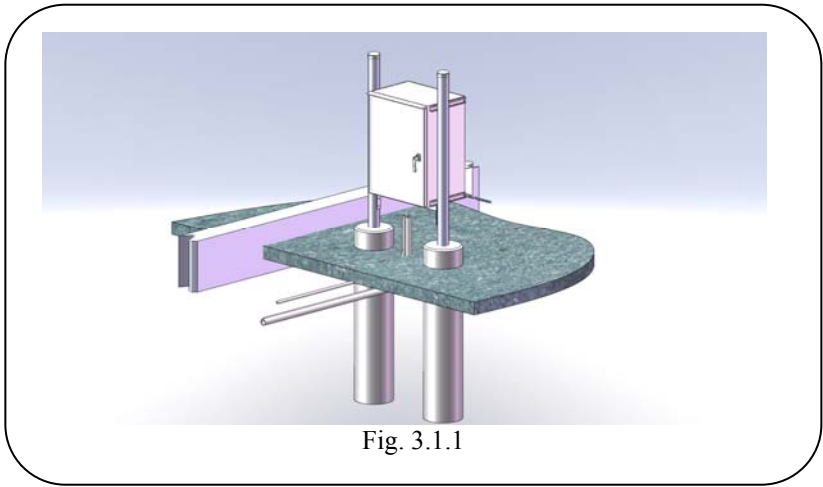

Fig. 3.1.1

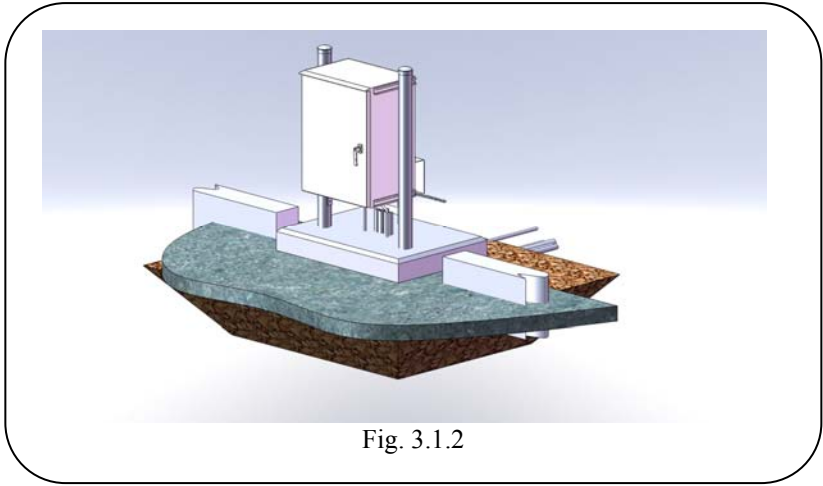

Fig. 3.1.2

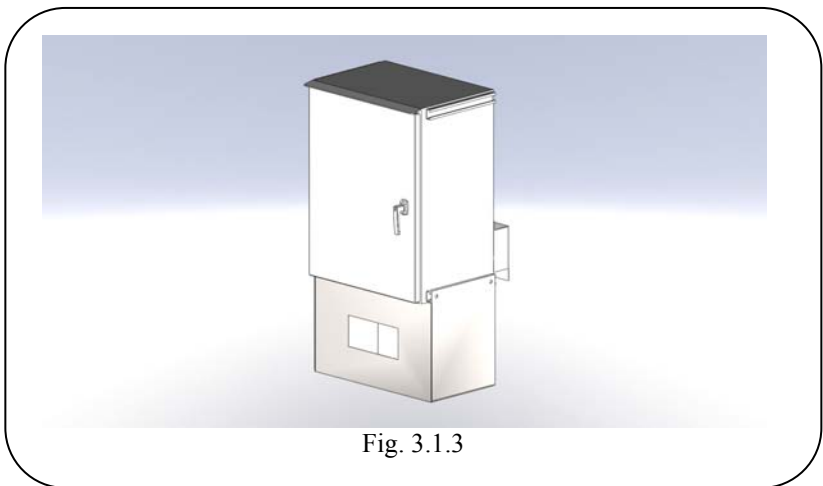

Fig. 3.1.3

3.2 Main chain adjustment:

It is very important to maintain the chain tension to a value between 1" to 1-1/2" of lowering down for each 10 feet of chain. With the threaded rods at each end of the chain, adjust the tension following the recommendation.

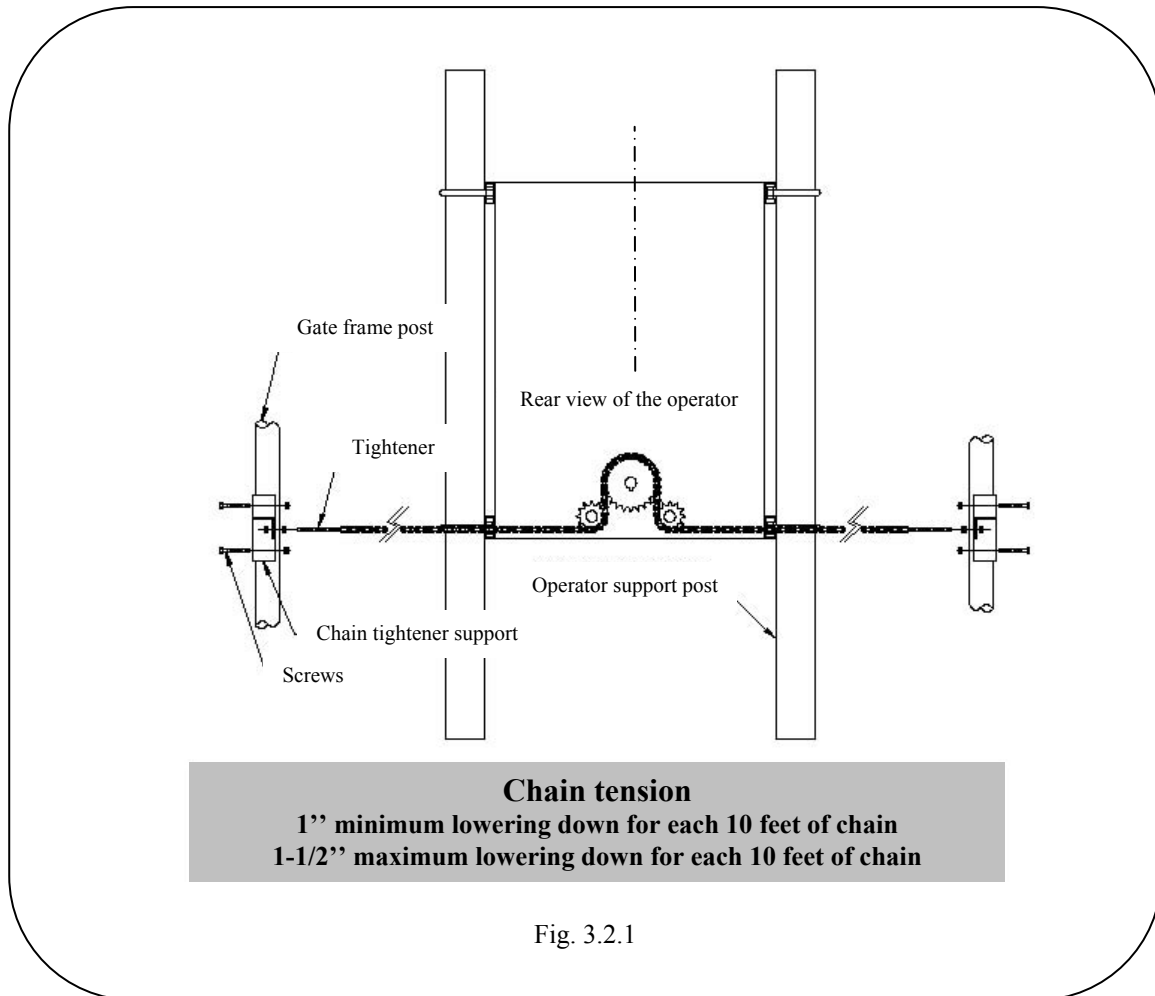

Fig. 3.2.1

3.3 Limit switches adjustments:

With a screwdriver, raise the cams stopping plate and then, screw or unscrew the cams located on the worm gear to get proper adjustment. Make sure the cams stopping plate is well fitted in the cams when released.

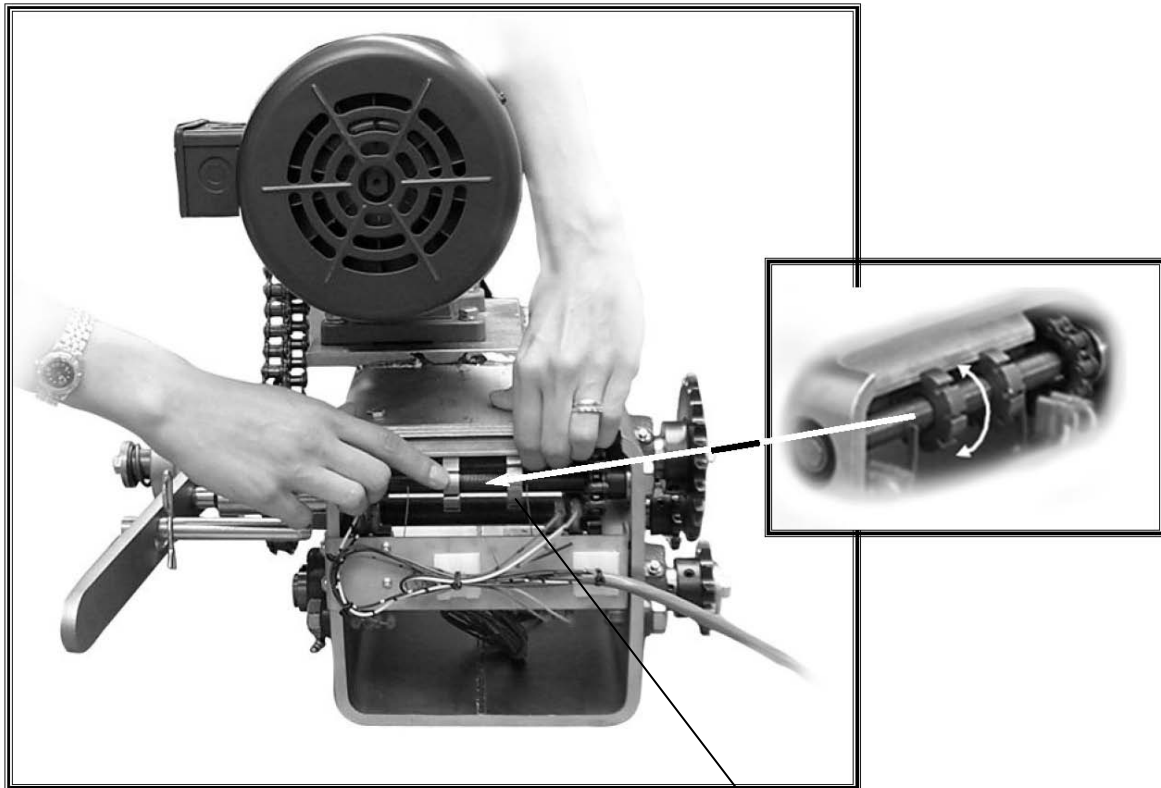

Fig. 3.3.1

Two limit setting cams

3.4 Torque limiter adjustment:

Partially unscrew the jam screw of the torque limiter nut. With a dynamometrical key and a 2-3/16" socket, adjust the torque limiter to 35 lbs/ft. Tighten the jam screw to keep desired adjustment.

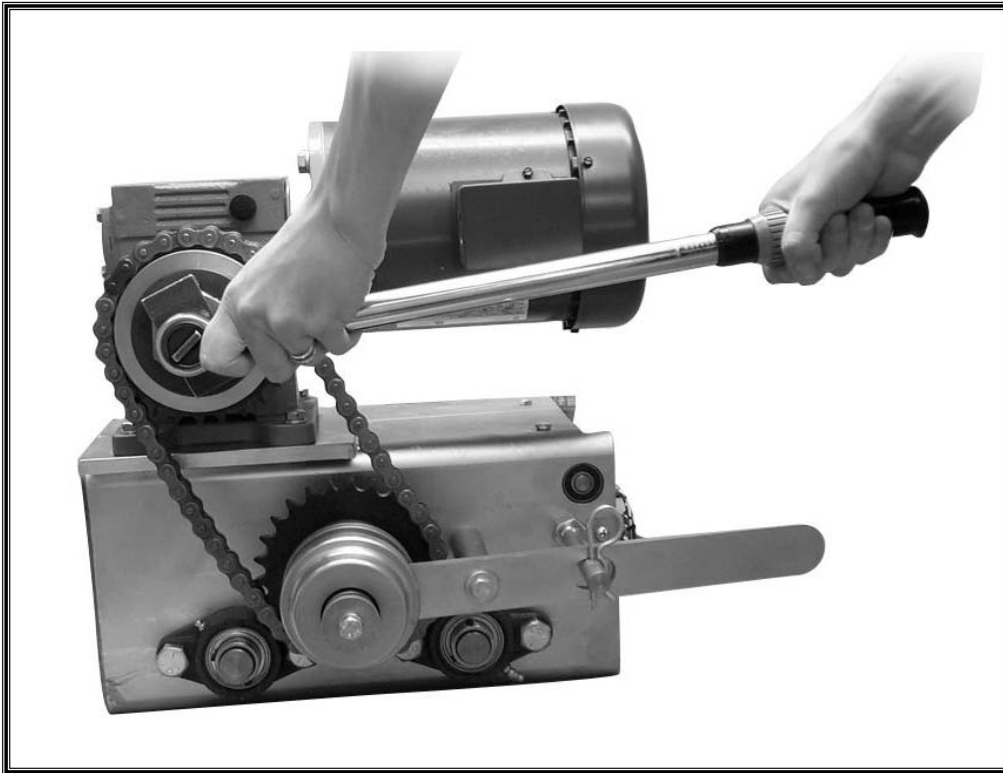

Fig. 3.4.1

NOTE:

It is highly not recommended to tighten the torque limiter to a pressure higher than 35 lbs/ft. Most sliding gates will properly function with this pressure. Pressure can be put up to 40 lbs/ft for very long and/or heavy gates. If the torque limiter is too tightened, the gate and/or the operator could be damage when the gate will hit an obstacle.

3.5 Disengaging mechanism:

To manually operate the gate, follow the steps below:

1. Remove the dowel pin;
2. Push the arm to free the coupling mechanism;
3. Insert the dowel pin in the hole to keep the arm in “manual” position;
4. The gate can now be operated manually with no effects on the system.

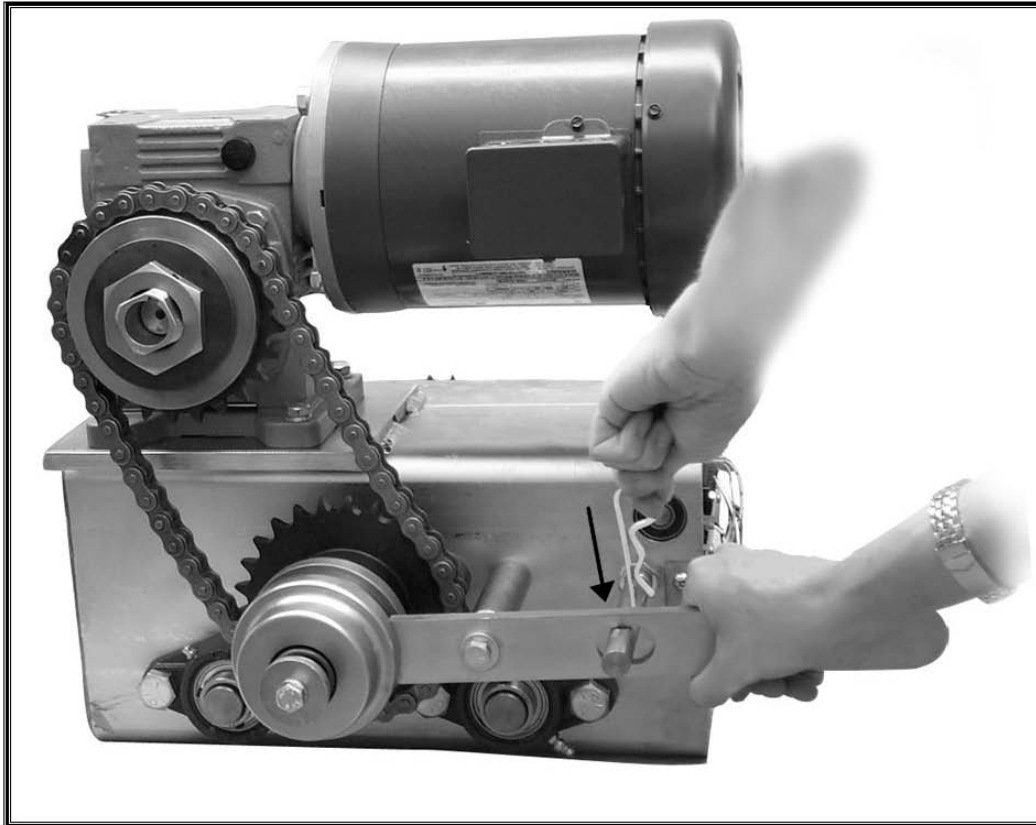

Fig. 3.5.1

3.6 Photocell beam wiring:

Primary protection against entrapment

To reduce the risk of entrapment, you must install photocell beam beams that shall cover the area along the gate's run as shown in fig. 3.6. To comply with UL 325 standard, use Omron E3K-R10K4.

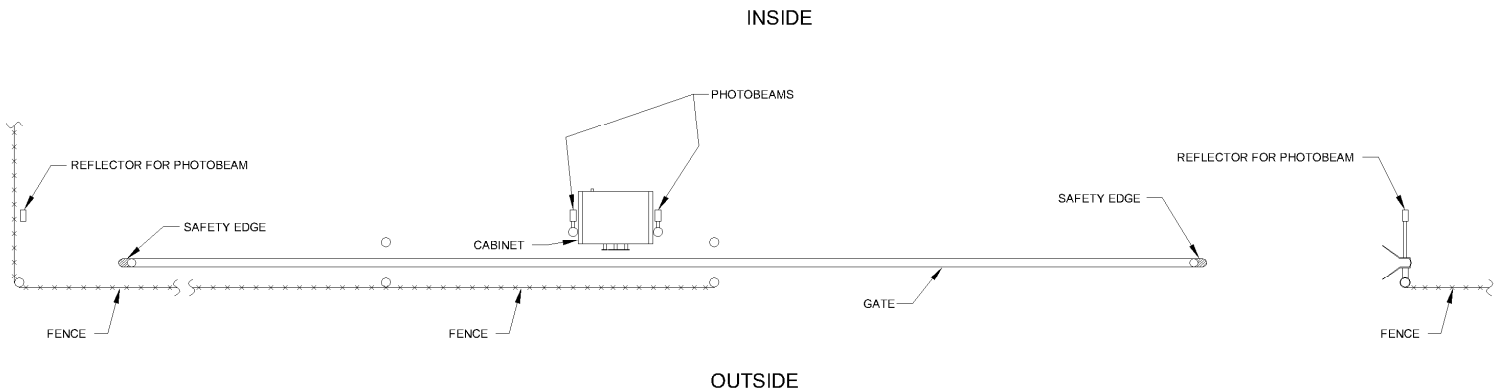

Fig. 3.6

For electrical wirings of the photocell, see electrical drawing BC14-TRS-EL (three phases power supply) or BC14-MN-EL (single phase power supply).

3.7 Safety edges wiring:

Secondary protection against entrapment

To reduce the risk of entrapment, you must install two safety edges, one at each end of the gate, as shown in fig. 3.6. To comply with UL 325 standard, use Miller Edge #ME123.

Also, it is the sole responsibility of the installer to add one or more safety edges where the risk of entrapment and obstruction exists, such as the leading edge, trailing edge, and post mounted both inside and outside of the gate.

For electrical wirings of the safety edges, see electrical drawing BC14-TRS-EL (three phases power supply) or BC14-MN-EL (single phase power supply).

3.8 Placards installation:

Two rigid placards with warning signs are supplied with the operator. It is the sole responsibility of the installer to put these placards, one on each side of the gate where easily visible.

3.9 Electrical wirings:

Electrical wirings and cables must be permanent and must follow all local rules and codes.

Power supply

For size of cables required, refer to your local electrical code. For the wirings in the control panel of the operator, refer to the electrical drawing BC14-TRS-EL (three phases power supply) or BC14-MN-EL (single phase power supply) at the end of this document. Once the wirings are done, check proper operation of the gate, especially the safety edges. When activated, the safety edge must reverse the gate movement.

The main breaker of the electrical panel on which is connected the operator must be of at least 15 A.

Options

For all options which require electrical wirings, refer to the electrical drawings included in this technical manual and to the installation sheets supplied with the corresponding options.

4. MAINTENANCE MANUAL

This section gives the necessary information for the maintenance of your gate operator to get optimal performance. The gate operator, model BCSI, has been designed to meet the high standards of the industry and the harsh climatic conditions of Quebec.

Before doing any lubrication operation, maintenance or verification of the mechanism, make sure to shut down power supply.

“IMPORTANT WARNING”

“Always shut down power supply before maintenance.”

Maintenance

The sliding gate and its operator consist in many mechanical parts that require regular maintenance to be performed as per the attached maintenance guide. Before maintenance, always open the electrical power circuit. Maintenance and adjustments must always be conducted by qualified technicians. The non compliance of the recommended maintenance will VOID the warranty. In that case, the customer will have to assume the fees for repairs to be done consequently.

Winter maintenance

- **Snow removal**

To operate properly, the traveling space of the gate must be kept free of snow and/or ice accumulation. Ice accumulation can cause major breakages to the different components. These breakages are not covered by the warranty. All service calls to repair a sliding gate or its operator which is blocked by snow or ice are not covered by the warranty.

Recommandations :

- A complete inspection must be performed after a breakage or any damage caused to the gate.
- The maintenance frequency must be increased if the gate is under intensive operations.

Breakdown service procedure:

The operator is not working:

- Check the electrical power supply;
- Check that the disconnecting switch on the operator is set to "ON";
- Check that the thermal relay is released;
- Check the fuses on the control panel;
- Check if a remote button shut off or a key switch is activated;
- If the operator is still not working following all the previous verifications, contact a specialized technician.

The gate is not automatically closing after completing the opening cycle:

- Check if the gate has entirely completed the opening cycle by manually pressing the limit switch;
- Check if the security devices, such as detection loops, photoelectric cell or any other equipment are not still activated;
- Make sure that the automatic closing function is activated (the potentiometer of the PLC is "OFF").

Service call – minimum 2 hours (plus parts and taxes)

For maintenance, see on next page the recommended steps to follow.

5. INSPECTION REPORT

Model : **BCSI** ___ ; Date : _____ ; Page ___ / ___ ;
 Technician : _____ ; O.T. : _____ ; Gate serial # : _____ ; # operations : _____ ;
 Client name : _____ ; Gate localisation : _____ ;

Notes :	Conf. (✓) \ Non-conf. (N)	* Corrected	N / A (N)	See notes (N)	Notes :	Conf. (✓) \ Non-conf. (N)	* Corrected	N / A (N)	See notes (N)
A – MECHANICAL PARTS INSPECTION					A22 – Springs : make adjustments to equilibrate the gate at 45°				
A1 – Operator concrete base : cracks, movement, stability					A23 – Limit switches cams : make adjustments				
A2 – Operator anchors : tighten nuts					A24 – Connecting rod : adjust the nut to level the gate. Tighten the jam nuts.				
A3 – Reducer : oil level and leakage, play in the reducer, crack in the box					A25 – Torque limiter : adjust				
A4 – Pulleys: fitting on the shaft, wear, pulleys alignment					B – ELECTRICAL COMPONENTS INSPECTION				
A5 – Belts A34 : replacement, tension adjustment					B1 – Electrical panel : voltages, check wires connections, proper behaviour of components				
A6 – Springs-system base plate hinge to operator frame : bearing bushing (maximum play 0.010")					B2 – Electrical motor : proper operation, installation				
A7 – Springs-system hinge to levers : bearing bushing (maximum play 0.010")					B3 – Crank switch : proper operation, installation				
A8 – Connecting rod hinge to connecting rod lever : bearing bushing (maximum play 0.010")					B4 – Limit switches : proper operation, installation				
A9 – Connecting rod hinge to torque limiter : bearing bushing (maximum play 0.010")					B5 – Heating element and thermostat : proper behaviour				
A10 – Spring sliding plate bearing bushing : maximum play 0.010"					B6 – Sound alarm : proper operation				
A11 – Connecting rod : deformation, cracks					B7 – Safety edge : proper operation				
A12 – Connecting rod lever : deformation, cracks. Tighten the 5/8" nuts to 250 lbs-ft , gradually and alternatively					C – LUBRICATION				
A13 – Springs-system levers : deformation, cracks. Tighten the 1/2" nuts to 160 lbs-ft , gradually and alternatively					C1 – Antifriction bearings on main shaft : lubricate				
A14 – Main shaft levers : deformation, cracks. Tighten the 3/8" nuts to 55 lbs-ft , gradually and alternatively.					C2 – Antifriction bearing on torque limiter shaft : lubricate				
A15 – Springs system : deformation, cracks					C3 – Springs-system columns : lubricate				
A16 – Springs : cracks, rupture.					C4 – Covers locks : lubricate				
A17 – Operator frame : deformation, cracks, corrosion					D – ACCESSORIES INSPECTION				
A18 – Doors and covers : deformation, insulating material, proper functioning of locks					D1 – Detection loops : insulation, electrical continuity and proper behaviour				
A19 – Driving arm : deformation, cracks, corrosion					D2 – Electrical photocell : proper operation, adjustments				
A20 – Driving arm : tighten the nuts following these : 1/2" to 75 lbs-ft with the gate and 3/4" to 380 lbs-ft with the operator					D3 – Pedestal : electromagnet operation, installation, alignment with gate, base stability				
A21 – Gate : structure, fence, nuts, gate path					D4 – Traffic lights : proper operation				
					D5 – Access system : proper operation, installation, base stability				
					E – CLEANING AND TOUCH-UP				
					E1 – Cleaning : grease and oil surplus, dust				
					E2 – Touch-up				
					F – FINAL CHECK				
					F1 – Proper operation of gate system				

* : ✓ – Immediate authorisation of works and repaired;
 R – refusal; Q – quote.

Notes :

Technician signature: _____ ; Client signature: _____

*LES NUMÉROS DE DESSIN FINISSANT PAR UN (X) SIGNIFIE QUE C'EST UN SOUS-ASSEMBLAGE

PIÈCES DU BOÎTIER POUR OPÉRATEUR BCSI			
# DESSIN		DESCRIPTION	QTÉ
NOUVEAU	ANCIEN		
BCSI-PM101X	BCSI-PM111	BOÎTIER OPÉRATEUR BCSI	1
BCSI-PM102X	BCSI-PM111	COUVERT POUR ARRIÈRE DU BOÎTIER	1
BCSI-PM103X	BCSI-PM111	PORTE DU BOÎTIER	1
BCSI-PM104	/	POIGNÉE POUR LA PORTE MODÈLE #501	1
BCSI-PM105	/	MÉCANISME DE LA SERRURE POUR LA PORTE DU BOÎTIER MODÈLE #	1
BCSI-PM106	/	PENTURE POUR LA PORTE DU BOÎTIER MODÈLE #	1
BCSI-PM107X	/	POTEAU DE MONTAGE DU BOÎTIER	2
BCSI-PM108	BCSI-PM110	CLIP D'ATTACHE DE POTEAU À CANTRUST	8
BCSI-PM109	/	BOULON HEXAGONAL 5/16-18 X 1 1/4"	4
BCSI-PM110	/	ÉCROU HEXAGONAL 5/16-18	4
BCSI-PM111X	BCSI-PM108X	SUPPORT OPÉRATEUR BCSI	1
BCSI-PM112	BCSI-PM109	BOULON HEXAGONAL 3/8-16 X 1"	4
BCSI-PM113XD	BCSI-PM107X	SUPPORT TENDEUR DE CHÂÎNE DROIT	1
BCSI-PM113XG	BCSI-PM107X	SUPPORT TENDEUR DE CHÂÎNE GAUCHE	1
BCSI-PM114	/	POTEAU DE LA BARRIÈRE EN ACIER GALVANISÉ Ø2-3/8"	2
BCSI-PM115	BCSI-PM104	BOULON HEXAGONAL 3/8-16 X 3 1/4"	6
BCSI-PM116	BCSI-PM105	RONDELLE PLATE 3/8"	6
BCSI-PM117	/	RONDELLE FREIN 3/8"	6
BCSI-PM118	BCSI-PM106	ÉCROU HEXAGONAL 3/8-16	6
BCSI-PM119X	BCSI-PM103X	TENDEUR DE CHÂÎNE STANDARD	1
BCSI-PM120X	/	TENDEUR DE CHÂÎNE RESSORT	1
BCSI-PM121	BCSI-PM102	MAILLON DE JONCTION #50	2
BCSI-PM122	BCSI-PM101	CHÂÎNE #50	1

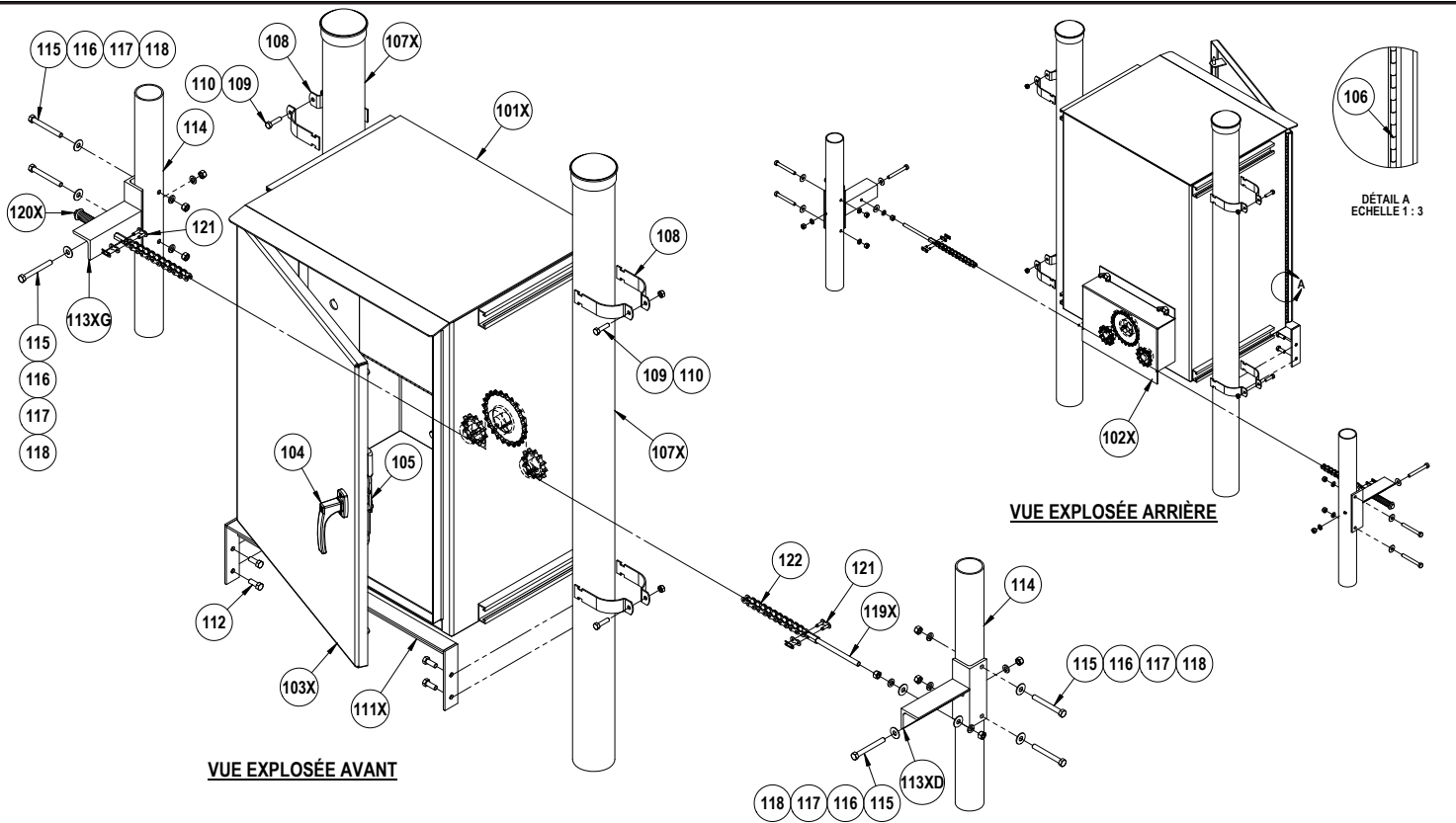

VUE EXPLOSÉE AVANT

VUE EXPLOSÉE ARRIÈRE

DÉTAIL A
ECHELLE 1 : 3

CLIENT:	NO DESSIN: BCSI-BTE-VE	REV: 0
DETAIL:	VUE EXPLOSÉE DU BÔÎTIER DE L'OPÉRATEUR BCSI	

*LES NUMÉROS DE DESSIN FINISSANT PAR UN (X) SIGNIFIE QUE C'EST UN SOUS-ASSEMBLAGE

PIÈCES DU BOÎTIER POUR OPÉRATEUR BCSI FIXÉ SUR BASE EN ACIER			
# DESSIN		DESCRIPTION	QTÉ
NOUVEAU	ANCIEN		
BCSI-PM101X	BCSI-PM111	BOÎTIER OPÉRATEUR BCSI	1
BCSI-PM102X	BCSI-PM111	COUVERT POUR ARRIÈRE DU BOÎTIER	1
BCSI-PM103X	BCSI-PM111	PORTE DU BOÎTIER	1
BCSI-PM104	/	POIGNÉE POUR LA PORTE MODÈLE #501	1
BCSI-PM105	/	MÉCANISME DE LA SERRURE POUR LA PORTE DU BOÎTIER MODÈLE #	1
BCSI-PM106	/	PENTURE POUR LA PORTE DU BOÎTIER MODÈLE #	1
BCSI-PM113XD	BCSI-PM107X	SUPPORT TENDEUR DE CHAÎNE DROIT	1
BCSI-PM113XG	BCSI-PM107X	SUPPORT TENDEUR DE CHAÎNE GAUCHE	1
BCSI-PM114	/	POTEAU DE LA BARRIÈRE EN ACIER GALVANISÉ Ø2-3/8"	2
BCSI-PM115	BCSI-PM104	BOULON HEXAGONAL 3/8-16 X 3 1/4"	6
BCSI-PM116	BCSI-PM105	RONDELLE PLATE 3/8"	6
BCSI-PM117	/	RONDELLE FREIN 3/8"	6
BCSI-PM118	BCSI-PM106	ÉCROIU HEXAGONAL 3/8-16	6
BCSI-PM119X	BCSI-PM103X	TENDEUR DE CHAÎNE STANDARD	1
BCSI-PM120X	/	TENDEUR DE CHAÎNE RESSORT	1
BCSI-PM121	BCSI-PM102	MAILLON DE JONCTION #50	2
BCSI-PM122	BCSI-PM101	CHAÎNE #50	1
BCSI-PM123X	/	BASE EN ACIER POUR FIXER L'OPÉRATEUR	1

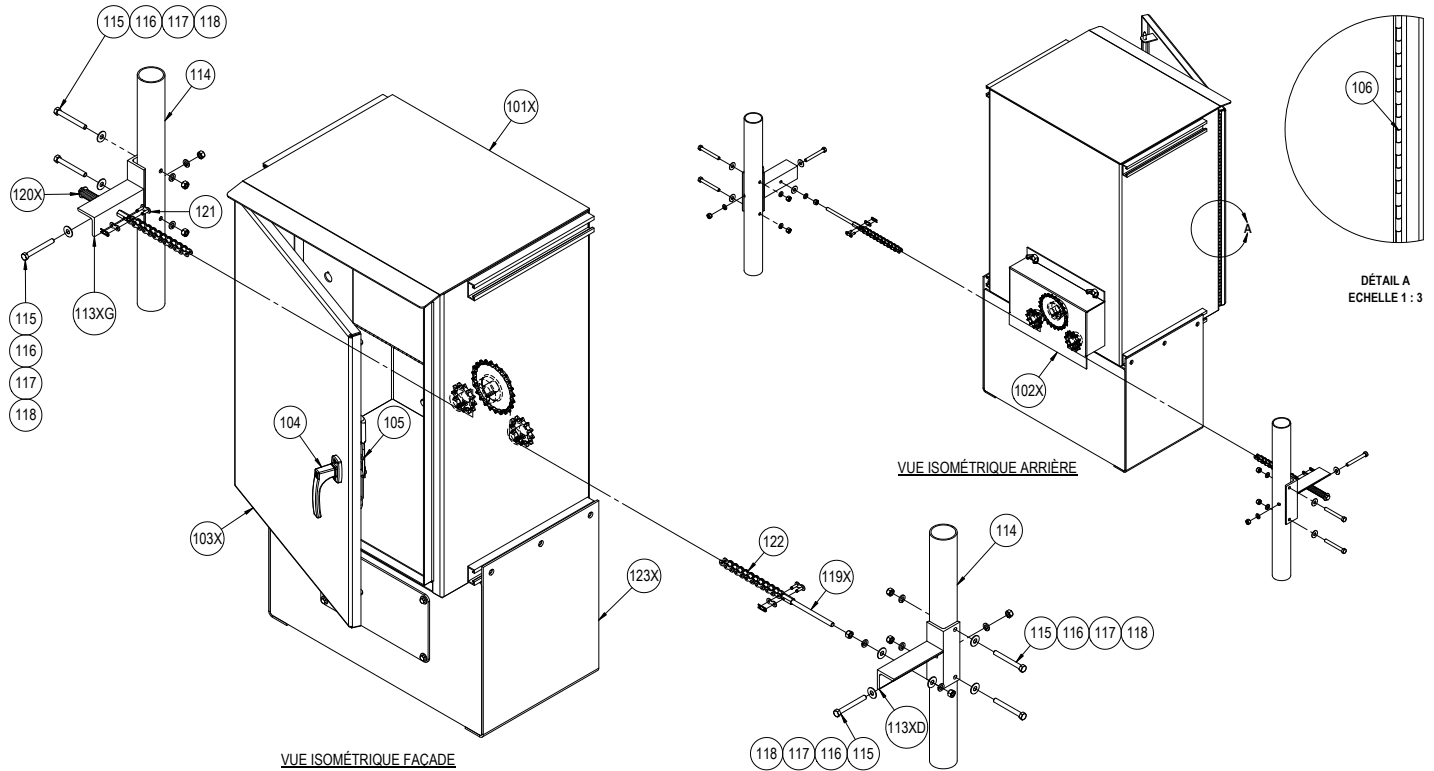

VUE ISOMÉTRIQUE FAÇADE

VUE ISOMÉTRIQUE ARRIÈRE

DÉTAIL A
ECHELLE 1 : 3

NOTE:
-LES PIÈCES #107X, 108, 109, 110, 111X ET 112
NE SONT PAS REPRÉSENTÉES SUR CE DESSIN, CAR CE SONT DES PIÈCES
POUR UN OPÉRATEUR FIXÉ ENTRE 2 POTEAUX.

CLIENT:	NO DESSIN: BCSI-BTE-VE-02	REV: 0
DETAIL: VUE EXPLOSÉE DU BOÎTIER DE L'OPÉRATEUR BCSI FIXÉ SUR UNE BASE EN ACIER		

*LES NUMÉROS DE DESSINS FINISSANT PAR UN (X) SIGNIFIE QUE C'EST UN SOUS-ASSEMBLAGE

PIÈCES DU MÉCANISME INTÉRIEUR OPÉRATEUR BCSI			
# DESSIN		DESCRIPTION	QTÉ
NOUVEAU	ANCIEN		
BCSI-PM01X	BCSI-PM01	BASE DU MÉCANISME	1
BCSI-PM02	BCSI-PM02	ROULEMENT À PALLIER 1" #FL205	6
BCSI-PM03	BCSI-PM03	BOULON HEX. 5/8-18NF X 1-1/4"	12
BCSI-PM04	BCSI-PM27	RÉDUCTEUR DE VITESSE AVEC HUILE SYNTHÉTIQUE	1
BCSI-PM05	/	BASE DU RÉDUTEUR DE VITESSE	1
BCSI-PM06	BCSI-PM40	BOULON HEX. 3/8-16UNC X 1-1/4"	4
BCSI-PM07	BCSI-PM13	RONDELLE AUTOBLOQUANTE 3/8"	12
BCSI-PM08	BCSI-PM28	MOTEUR SELON PLAQUE SIGNALITIQUE (TABLEAU DE RÉFÉRENCE)	1
BCSI-PM09	BCSI-PM26	BASE DU LIMITEUR DE COUPLE	1
BCSI-PM10	BCSI-PM22	PLAQUE DE FRICTION	2
BCSI-PM11	BCSI-PM25	BAGUE LUBRIFIÉE DEE CENTRAGE	1
BCSI-PM12	BCSI-PM23	DISQUE DE FRICTION EN PHÉNOLIQUE	2
BCSI-PM13	BCSI-PM24	PIGNON #50A26	1
BCSI-PM14	BCSI-PM21	RONDELLE À RESSORT BELLEVILLE	1
BCSI-PM15	BCSI-PM20	ÉCROU HEX. DE TENSION 1 1/2-12	1
BCSI-PM16	BCSI-PM17	CHAÎNE ET MAILLE D'ATTACHE	1
BCSI-PM17	BCSI-PM31	ARBRE SECONDAIRE	2
BCSI-PM18	BCSI-PM16	BAGUE DE RETENUE	4
BCSI-PM19	BCSI-PM42	CLAVETTE 1/4 X 1"	3
BCSI-PM20	BCSI-PM30	PIGNON #50B12	2
BCSI-PM21	BCSI-PM14	RONDELLE PLATE 3/8 SPÉCIALE	4
BCSI-PM22	BCSI-PM08	BOULON HEX. 3/8-16 X 1"	9
BCSI-PM23	BCSI-PM29	PIGNON #50B24	1
BCSI-PM24X	BCSI-PM19X	ARBRE D'ENTRAÎNEMENT	1
BCSI-PM25	BCSI-PM42	CLAVETTE 1/4 X 1 3/4"	1
BCSI-PM26	BCSI-PM41	ESPACEUR SYSTÈME DE DÉBRAYAGE	1
BCSI-PM27X	BCSI-PM18X	PIGNON #50B26 ET COUSSINET	1
BCSI-PM28X	BCSI-PM15X	ACCOUPLLEMENT DE DÉBRAYAGE	1
BCSI-PM29	BCSI-PM12	RESSORT DE COMPRESSION	1
BCSI-PM30	BCSI-PM09	PIVOT DU BRAS DE DÉBRAYAGE	1
BCSI-PM31	BCSI-PM10	BRAS DE DÉBRAYAGE	1
BCSI-PM32	BCSI-PM46	VIS À ÉPAULEMENT 1/2" X 1/2" FILET 3/8-16	1
BCSI-PM33	BCSI-PM05	ÉCROU HEX. 5/8-11	1

PIÈCES DU MÉCANISME INTÉRIEUR OPÉRATEUR BCSI (SUITE)

BCSI-PM34	BCSI-PM43	RESSORT DE DÉBRAYAGE	1
BCSI-PM35	BCSI-PM44	RONDELLE PLATE 5/8"	1
BCSI-PM36	BCSI-PM06	BOULON 5/8-11 X 6 3/4"	1
BCSI-PM37	BCSI-PM07	GOUPILLE DE RETENUE	1
BCSI-PM38	BCSI-PM35	ROULEMENT À BILLE	2
BCSI-PM39X	BCSI-PM37X	AXE DE POSITION	1
BCSI-PM40	BCSI-PM39	NOIX DIVISÉE	2
BCSI-PM41X	BCSI-PM04	CHAÎNE LIMIT SWITCH	1
BCSI-PM42	/	RONDELLE DE TENSION	1
BCSI-PM43	/	ANNEAU DE RETENUE DE L'AXE DES FIN DE COURSE	1
BCSI-PM44	/	VIS MÉCANIQUE TÊTE RONDE 1/4-20 X 1/2"	5
BCSI-PM45	BCSI-PM36	PLAQUE DE RETENUE DES NOIX DIVISÉES	1
BCSI-PM46	BCSI-PM32	BOULON HEX. 1/4-20 X 1 3/4"	2
BCSI-PM47	BCSI-PM33	RESSORT	2
BCSI-PM48	BCSI-PM34	ÉCROU HEX. NYLON 1/4-20	2
BCSI-PM49	BCSI-PM38	PLAQUE INTERRUPTEUR DE FIN DE COURSE	1
BCSI-PM50	/	INTERRUPTEUR DE FIN DE COURSE	2
BCSI-PM51	/	VIS À TÊTE RONDE #6-32 X 1"	4
BCSI-PM52	/	ÉCROU HEX. #6-32	8
BCSI-PM53	/	RONDELLE AUTOBLOQUANTE ÉTOILÉE #6	4
BCSI-PM54	/	ÉLÉMENT CHAUFFANT	1
BCSI-PM55	/	VIS DE PRESSION 1/4-20 X 1"	4
BCSI-PM56	/	RONDELLE PLATE 1/4"	2
BCSI-PM57	/	ÉCROU HEX. 1/4-20	2

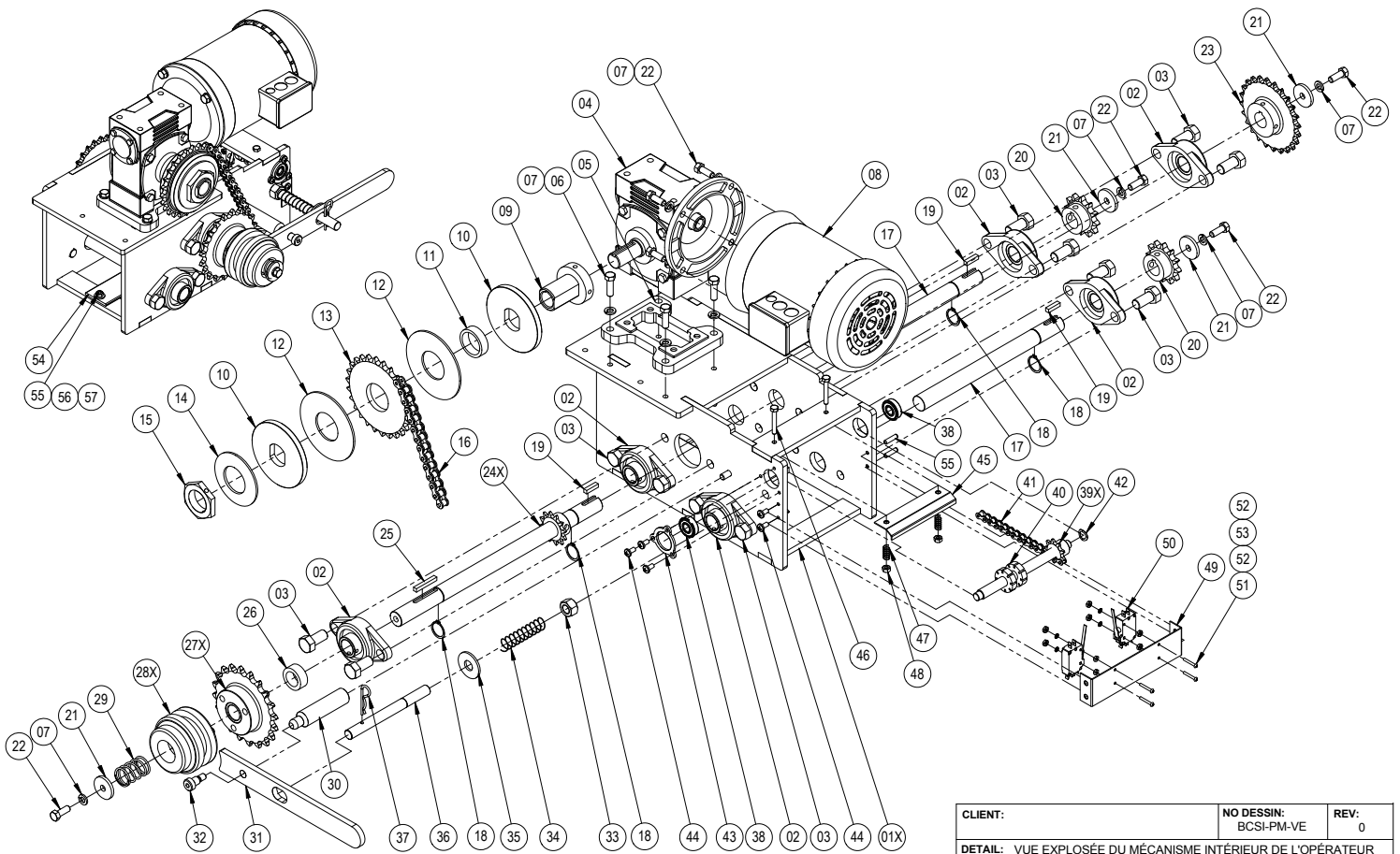

CLIENT:	NO DESSIN: BCSI-PM-VE	REV: 0
DETAIL: VUE EXPLOSÉE DU MÉCANISME INTÉRIEUR DE L'OPÉRATEUR DE BARRIÈRE COULISSANTE BCSI		

**L'ensemble d'axes d'entrainement
et d'engrenages inclus:**

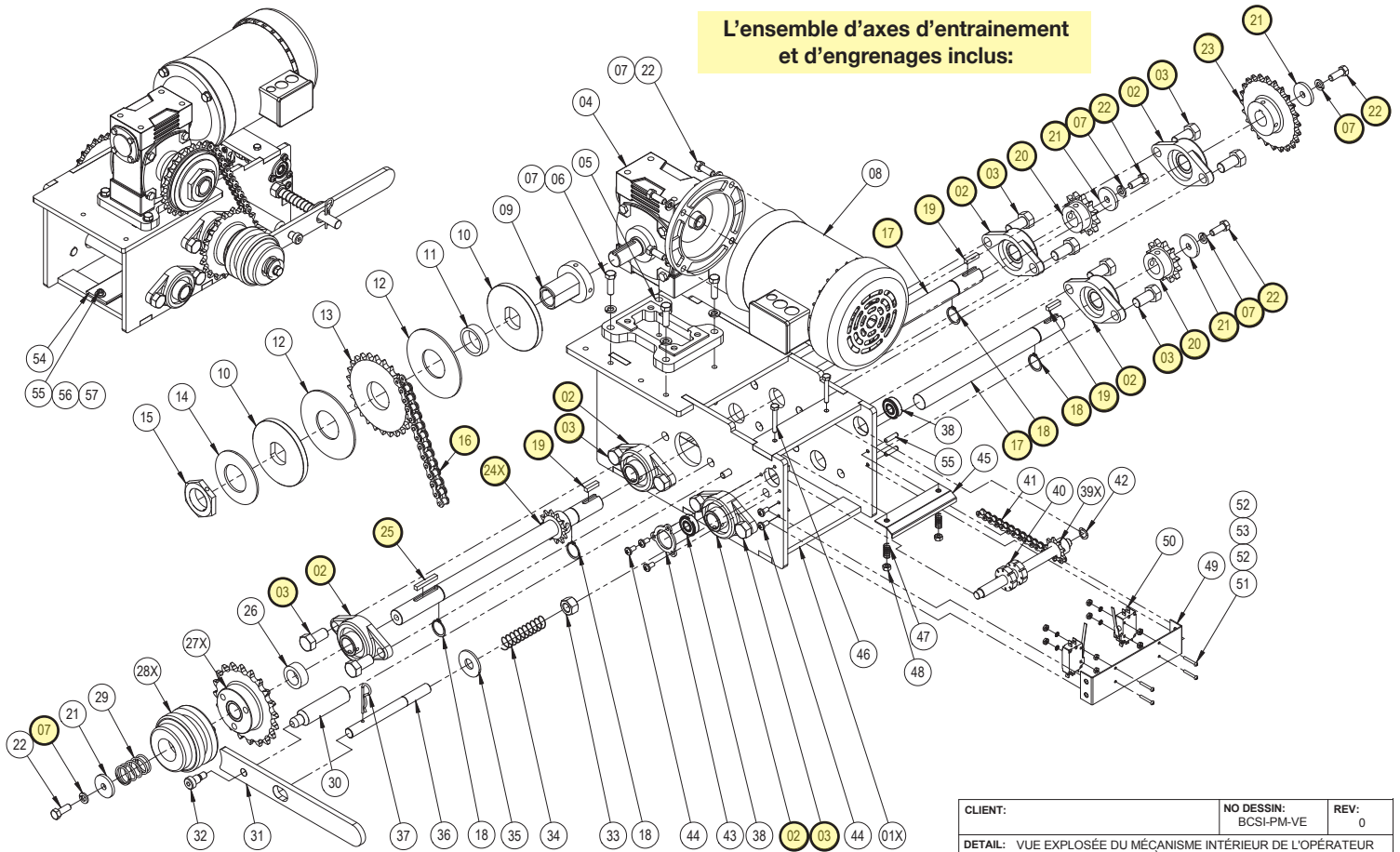

CLIENT:	NO DESSIN: BCSI-PM-VE	REV: 0
DETAIL: VUE EXPLOSÉE DU MÉCANISME INTÉRIEUR DE L'OPÉRATEUR DE BARRIÈRE COULISSANTE BCSI		

L'ensemble d'axe de fin de course
inclus:

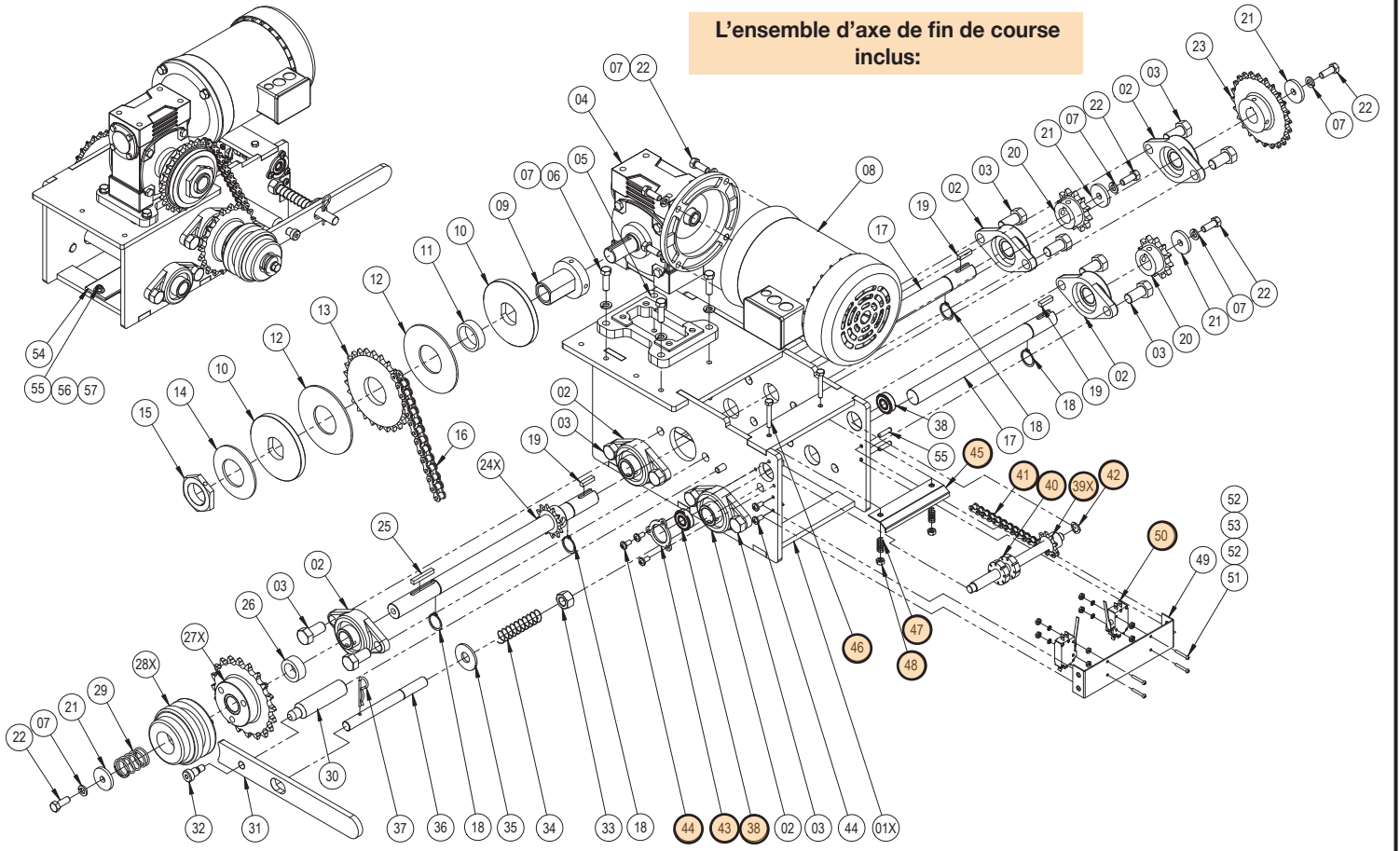

L'ensemble de disques de friction inclus:

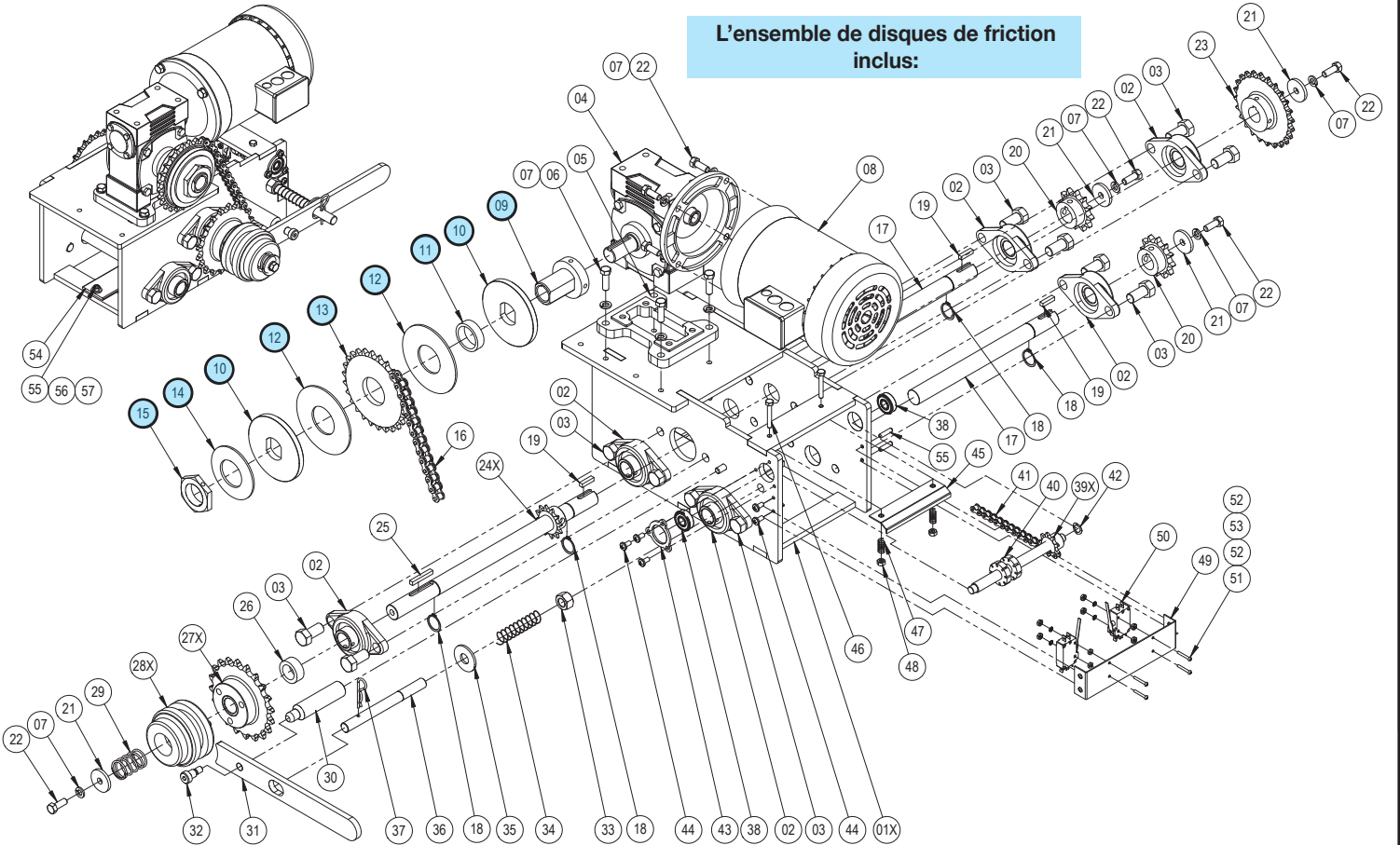

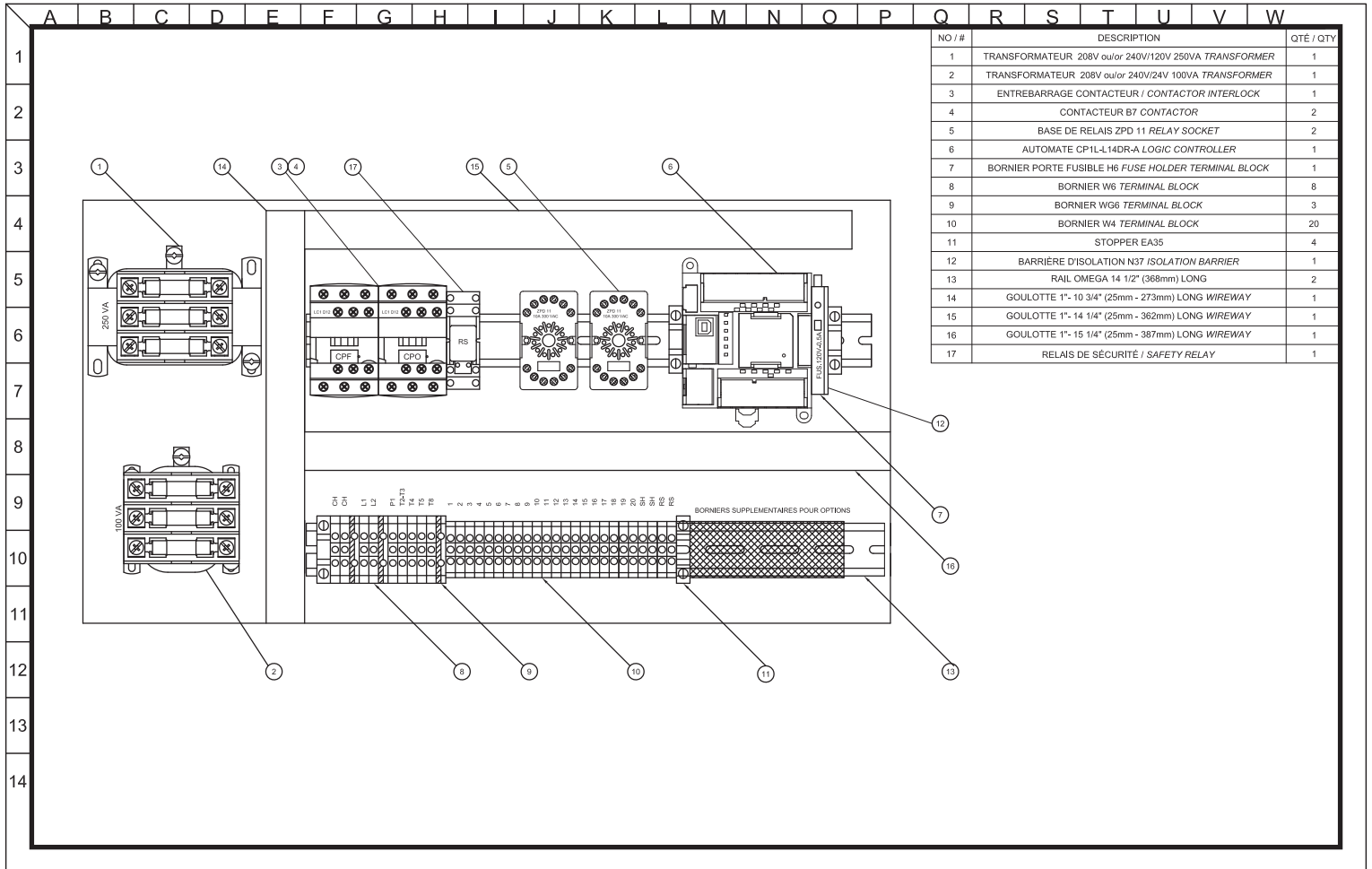

NO / #	DESCRIPTION	QTÉ / QTY
1	TRANSFORMATEUR 208V ou/ou 240V/120V 250VA TRANSFORMER	1
2	TRANSFORMATEUR 208V ou/ou 240V/24V 100VA TRANSFORMER	1
3	ENTREBARRAGE CONTACTEUR / CONTACTOR INTERLOCK	1
4	CONTACTEUR B7 CONTACTOR	2
5	BASE DE RELAIS ZPD 11 RELAY SOCKET	2
6	AUTOMATE CP1L-L14DR-A LOGIC CONTROLLER	1
7	BORNIER PORTE FUSIBLE H6 FUSE HOLDER TERMINAL BLOCK	1
8	BORNIER W6 TERMINAL BLOCK	8
9	BORNIER W6 TERMINAL BLOCK	3
10	BORNIER W4 TERMINAL BLOCK	20
11	STOPPER EA35	4
12	BARRIÈRE D'ISOLATION N37 ISOLATION BARRIER	1
13	RAIL OMEGA 14 1/2" (368mm) LONG	2
14	GOULOTTE 1"- 10 3/4" (25mm - 273mm) LONG WIREWAY	1
15	GOULOTTE 1"- 14 1/4" (25mm - 362mm) LONG WIREWAY	1
16	GOULOTTE 1"- 15 1/4" (25mm - 387mm) LONG WIREWAY	1
17	RELAIS DE SÉCURITÉ / SAFETY RELAY	1

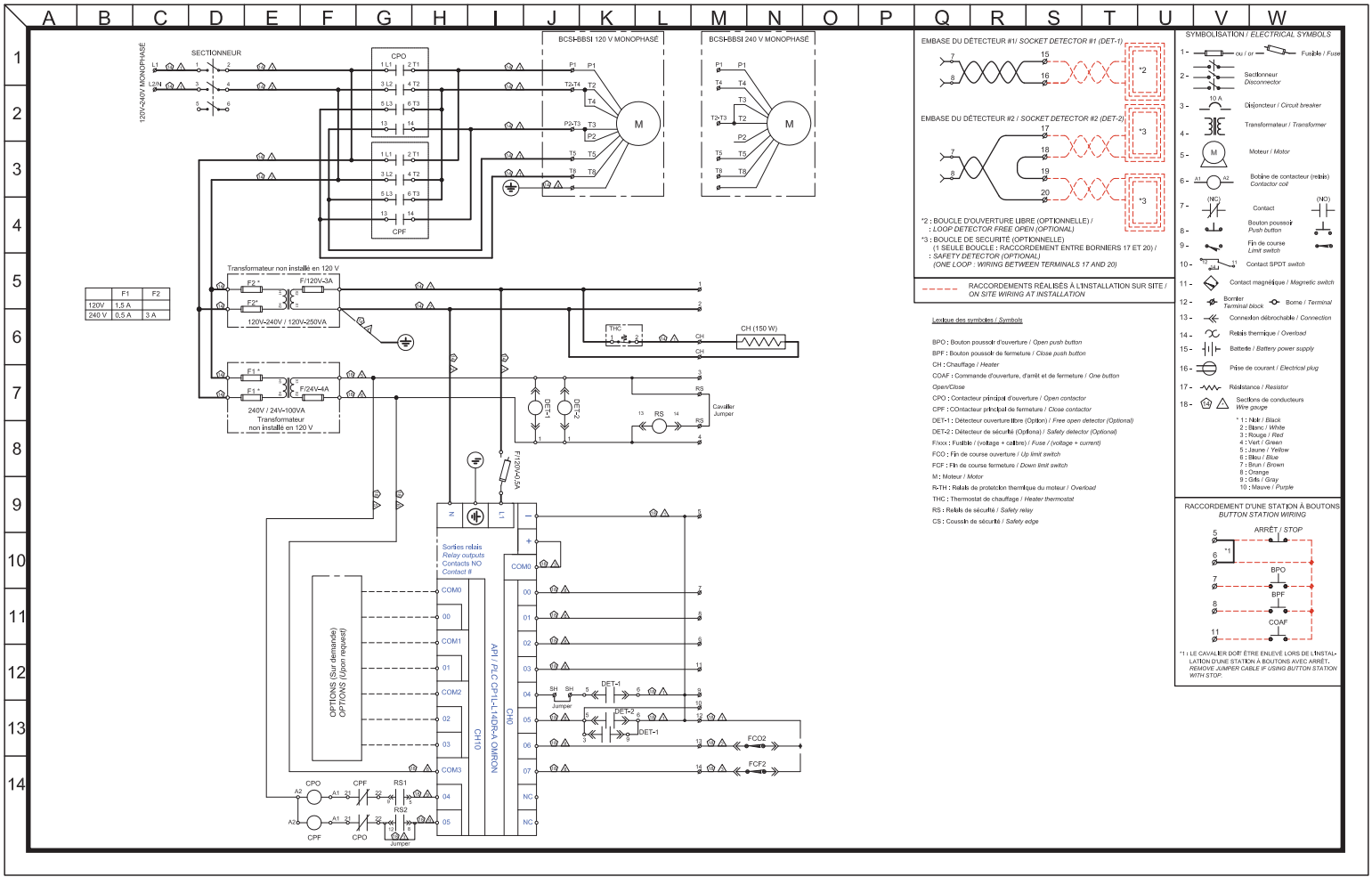

	F1	F2
120V	1.5 A	3 A
240V	0.5 A	1 A

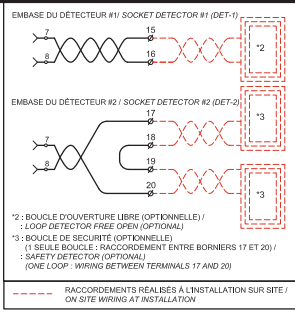

- SYMBOLISATION / ELECTRICAL SYMBOLS**
- ou / or
 - Sectionneur / Disconnector
 - 10 A Déjoncteur / Circuit breaker
 - Transformateur / Transformer
 - Moteur / Motor
 - Boîtier de contacteur (nôble) / Contactor box
 - Contact (N.C.) / Contact
 - Bouton poussoir / Push button
 - Fil de course / Limit switch
 - Contact SPDT switch
 - Contact magnétique / Magnetic switch
 - Bornier / Terminal block
 - Connexion détachable / Connection
 - Relais thermique / Overload
 - Batterie / Battery power supply
 - Prise de courant / Electrical plug
 - Résistance / Resistor
 - Soudure de conducteurs / Wire gauge
- RACCORDEMENT D'UNE STATION À BOUTONS / BUTTON STATION WIRING**
-
- 11: LE CAVAILER DOIT ÊTRE ENLEVÉ LORS DE L'INSTALLATION D'UNE STATION À BOUTONS AVEC ARRÊT. REMOVE JUMPER CABLE IF USING BUTTON STATION WITH STOP.

- Legende des symboles / Symbols**
- BPO: Bouton poussoir d'ouverture / Open push button
 - BPF: Bouton poussoir de fermeture / Close push button
 - CH: Chauffage / Heater
 - CQAF: Commande d'ouverture, d'arrêt et de fermeture / One button Open/Close
 - CPO: Contacteur principal d'ouverture / Open contactor
 - CPF: Contacteur principal de fermeture / Close contactor
 - DET-1: Détecteur ouverture libre (Option) / Free open detector (Optional)
 - DET-2: Détecteur de sécurité (Option) / Safety detector (Optional)
 - F1: Fusible (voltagé + calibre) / Fuse (voltage + current)
 - F2: Fil de course fermeture / Up limit switch
 - F3: Fil de course ouverture / Down limit switch
 - M: Moteur / Motor
 - RS: Relais de protection thermique du moteur / Overload
 - TH: Thermostat de chauffage / Heater thermostat
 - RS: Relais de sécurité / Safety relay
 - CS: Coussin de sécurité / Safety edge

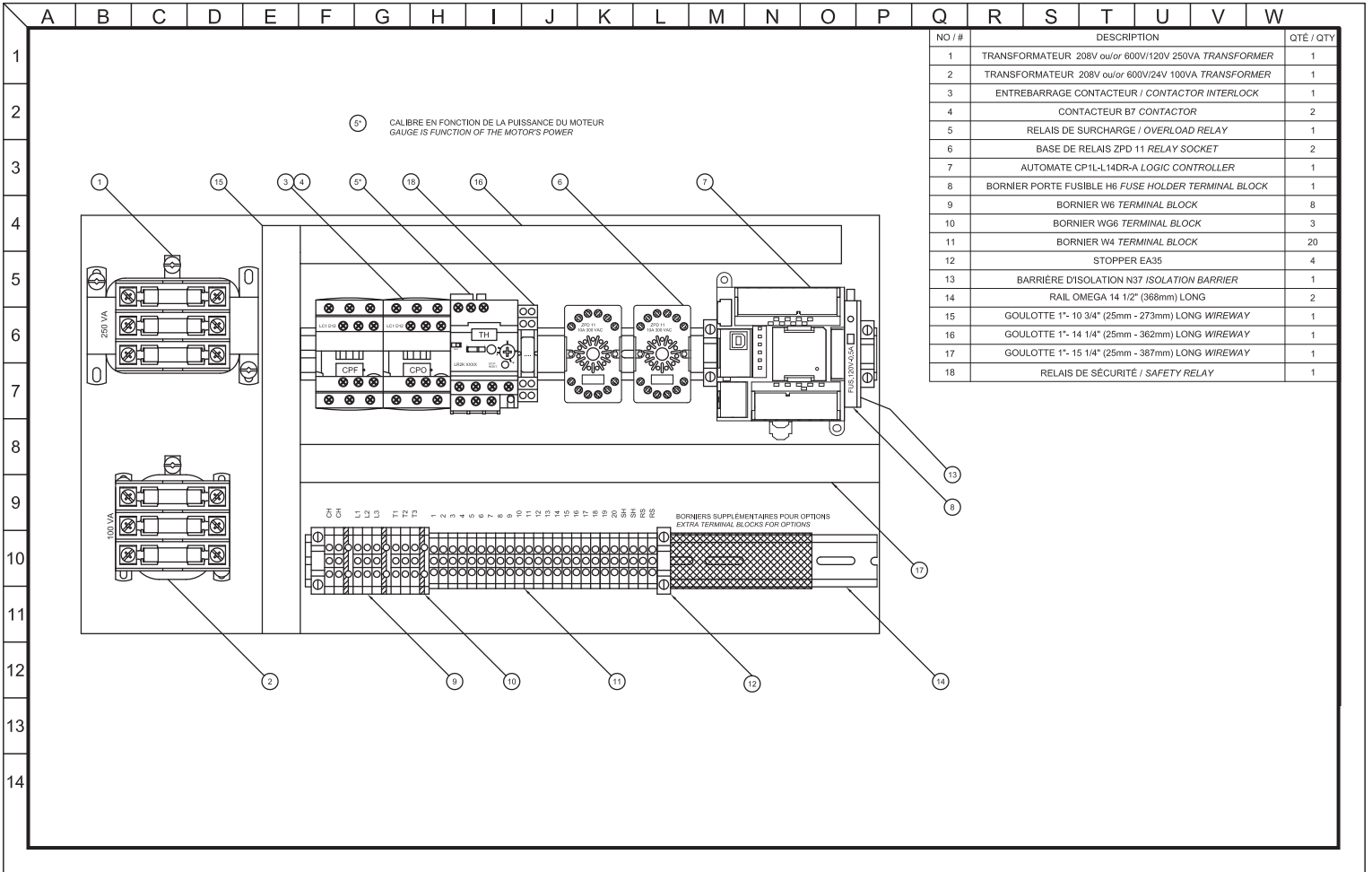

NO / #	DESCRIPTION	QTE / QTY
1	TRANSFORMATEUR 208V ou/or 600V/120V 250VA TRANSFORMER	1
2	TRANSFORMATEUR 208V ou/or 600V/24V 100VA TRANSFORMER	1
3	ENTREBARRAGE CONTACTEUR / CONTACTOR INTERLOCK	1
4	CONTACTEUR B7 CONTACTOR	2
5	RELAIS DE SURCHARGE / OVERLOAD RELAY	1
6	BASE DE RELAIS ZPD 11 RELAY SOCKET	2
7	AUTOMATE CP1L-L14DR-A LOGIC CONTROLLER	1
8	BORNIER PORTE FUSIBLE H6 FUSE HOLDER TERMINAL BLOCK	1
9	BORNIER W6 TERMINAL BLOCK	8
10	BORNIER W66 TERMINAL BLOCK	3
11	BORNIER W4 TERMINAL BLOCK	20
12	STOPPER EA35	4
13	BARRIERE D'ISOLATION N37 ISOLATION BARRIER	1
14	RAIL OMEGA 14 1/2" (368mm) LONG	2
15	GOULOTTE 1" - 10 3/4" (25mm - 273mm) LONG WIREWAY	1
16	GOULOTTE 1" - 14 1/4" (25mm - 362mm) LONG WIREWAY	1
17	GOULOTTE 1" - 15 1/4" (25mm - 387mm) LONG WIREWAY	1
18	RELAIS DE SECURITE / SAFETY RELAY	1

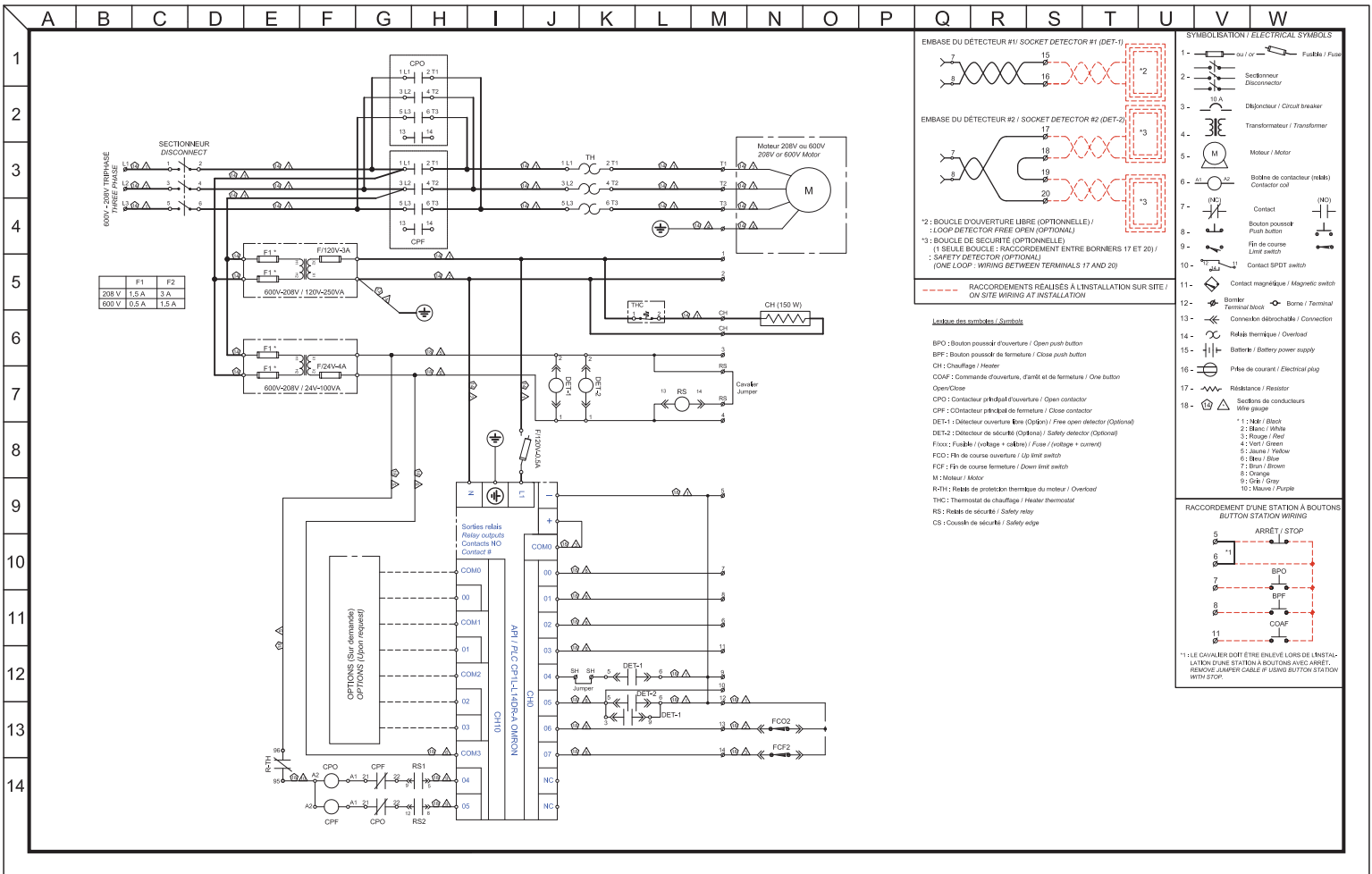

	F1	F2
208 V	1,5 A	3 A
600 V	0,5 A	1,5 A

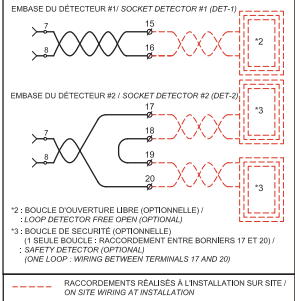

SYMBOLISATION / ELECTRICAL SYMBOLS	
1.	au / or
2.	Sectionneur / Disconnect
3.	Dépendeur / Circuit breaker
4.	Transformateur / Transformer
5.	Moteur / Motor
6.	Boîtier de contacteur (néb) / Contactor box
7.	Contact / Contact
8.	Bouton poussoir / Push button
9.	Fin de course / Limit switch
10.	Contact SPDT switch
11.	Contact magnétique / Magnetic switch
12.	Bornier / Terminal
13.	Connexion débranchable / Connection
14.	Relais thermique / Overload
15.	Batterie / Battery power supply
16.	Pièce de courant / Electrical plug
17.	Résistance / Resistor
18.	Sections de conducteurs / Wire gauge

Legende des symboles / Symbols

- BPO : Bouton poussoir d'ouverture / Open push button
- BPF : Bouton poussoir de fermeture / Close push button
- CH : Chauffage / Heater
- COMF : Commande d'ouverture, d'arrêt et de fermeture / One button Open/Close
- CPO : Contacteur 2R-1R d'ouverture / Open contactor
- CPF : Contacteur principal de fermeture / Close contactor
- DET-1 : Détecteur ouverture Ene (Opéra) / Free open detector (Optional)
- DET-2 : Détecteur de sécurité (Opéra) / Safety detector (Optional)
- F1 ou F2 : Fusible / (voltagé + câbles) / Fuse / (voltagé + current)
- FCO : Fin de course ouverture / Up limit switch
- FCF : Fin de course fermeture / Down limit switch
- M : Moteur / Motor
- RTH : Relais de protection thermique du moteur / Overload
- TH : Thermostat de chauffage / Heater thermostat
- RS : Relais de sécurité / Safety relay
- CS : Coque de sécurité / Safety edge

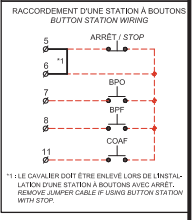

*11: LE CAVALIER DOIT ÊTRE ENLEVÉ LORS DE L'INSTALLATION D'UNE STATION À BOUTONS AVEC ARRÊT. REMOVE JUMPER CABLE IF USING BUTTON STATION WITH STOP.

***HOW TO ORDER
REPAIR PARTS***

DEVANCO CANADA

19192 HAY ROAD, UNIT Q
SUMMERSTOWN, ON K0C 2E0

TOLL FREE: 855-931-3334
www.devancocanada.com

**WHEN ORDERING REPAIR PARTS
PLEASE SUPPLY THE
FOLLOWING INFORMATION:**

- ✓ PART NUMBER**
- ✓ DESCRIPTION**
- ✓ MODEL NUMBER**