

1. Disassemble the front cover from the housing by removing the two provided cover mounting screws (5/8" stainless steel 8-32 thread).
2. Install wall anchors that accept up to 5/16" thread screws (not supplied), using the mounting dimensions on the reverse of this page as reference, in preparation to fasten the enclosure to the wall.
3. Run and mount conduit (not provided) through or up the wall to meet either the back center or bottom of the housing, and remove the appropriate 7/8" knockout. **DO NOT CONNECT CONDUIT/WIRING THROUGH THE TOP OR SIDE OF THE ENCLOSURE.**
4. Mount the rear foam backing gasket and secure the enclosure to the wall using 4 (four) 1/4" or 5/16" thread stainless steel wall mounting screws (no provided), and connect the conduit to the enclosure using a suitable connector.
5. Run the wiring and then connect to the clearly marked terminals on the rear of the front cover of the light (see front cover inside view and power draw information on next page for reference).
6. Fasten the light to the mounted enclosure using the cover mounting screws.

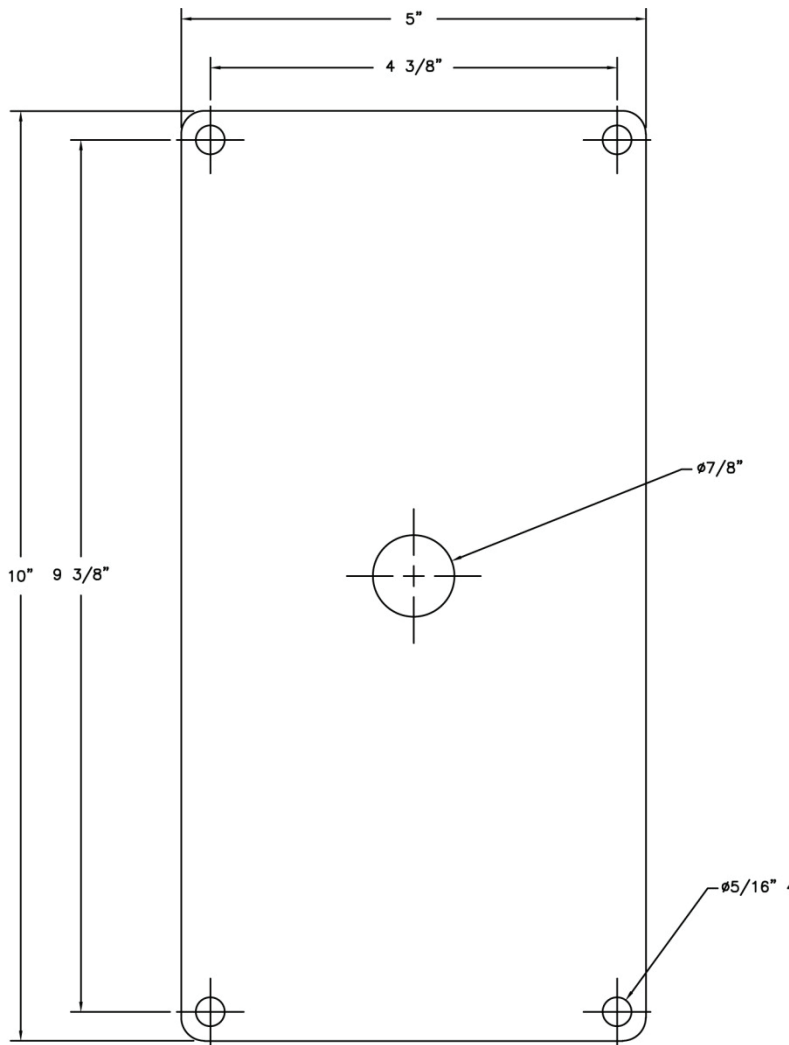

Mounting Hole Dimensions  
(not to scale)

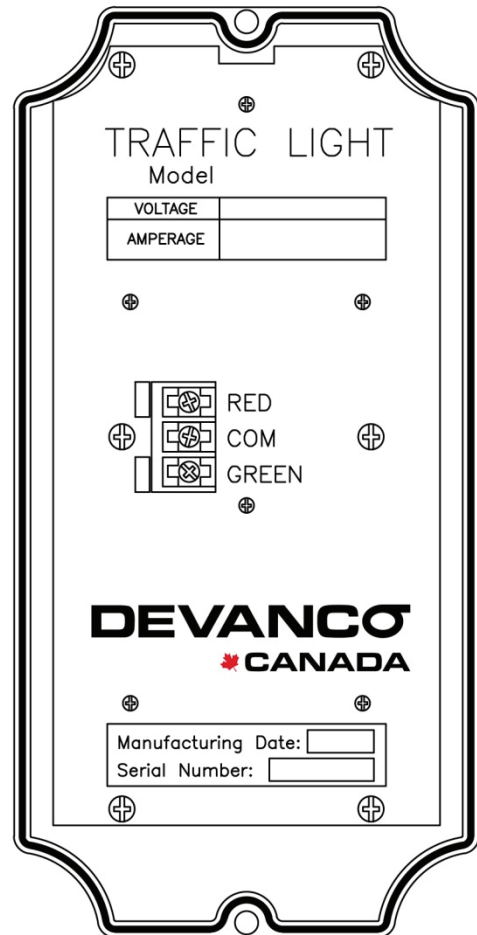

Front Cover  
Inside View

**POWER DRAW:**

12 Volt at 140 mA  
24 Volt at 70 mA  
120 Volt at 30 mA

**ORDERING INFORMATION:**

Part# YSG12-24LED: 10-32V AC/DC, Yellow  
Part# YSG115-LED: 120V AC, Yellow  
Part# BSG12-24LED: 10-32V AC/DC, Black  
Part# BSG115-LED: 120V AC, Black

**HOW TO ORDER REPAIR PARTS**

**DEVANCO CANADA**

19192 HAY ROAD, UNIT Q  
SUMMERSTOWN, ON K0C 2E0

TOLL FREE: 855-931-3334  
[www.devancocanada.com](http://www.devancocanada.com)

**WHEN ORDERING REPAIR PARTS  
PLEASE SUPPLY THE FOLLOWING INFORMATION:**

✓ PART NUMBER ✓ DESCRIPTION ✓ MODEL NUMBER