

# SC LOW HEADROOM DEVICE

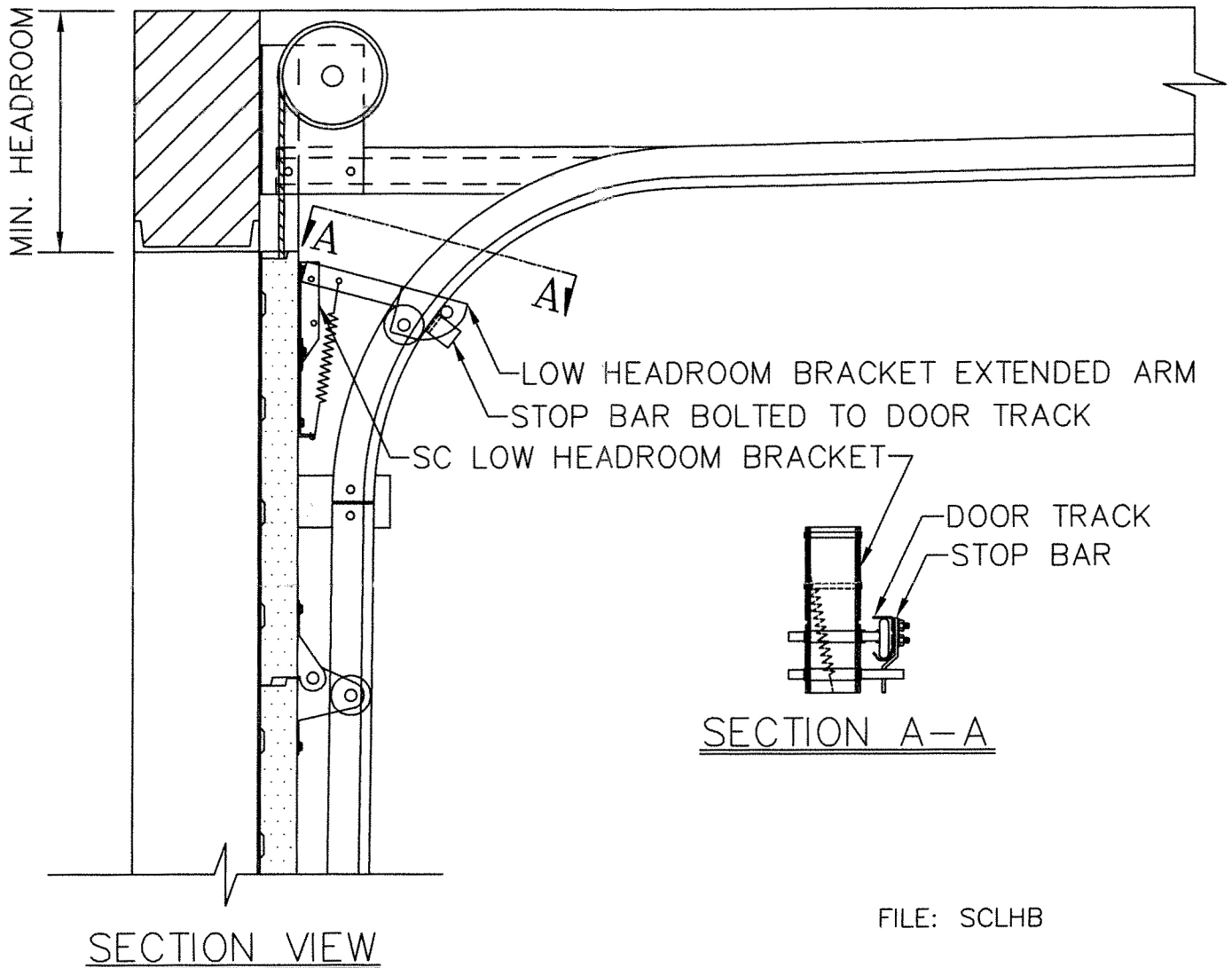

FILE: SCLHB

The Steel-Craft Model SC Low Headroom Device will reduce the normally required headroom by up to 4" on any standard lift overhead door with either 2" or 3" hardware. (Must be specify)

- 1-Cut a maximum of 4" off the bottom of both vertical tracks.
- 2-Mount the SC Low Headroom Device as high as possible on the inside face of the top section with the arm of the device extended as shown. (maximum 75 degree)
- 3-Drill two holes in each track to position the stop bars.

The stop bars are to be located as shown and positioned to ensure that each time the door is closed, the stop bar will engage the arm of the SC Device and force the top section of the door into position against the jamb and header weatherstrip.

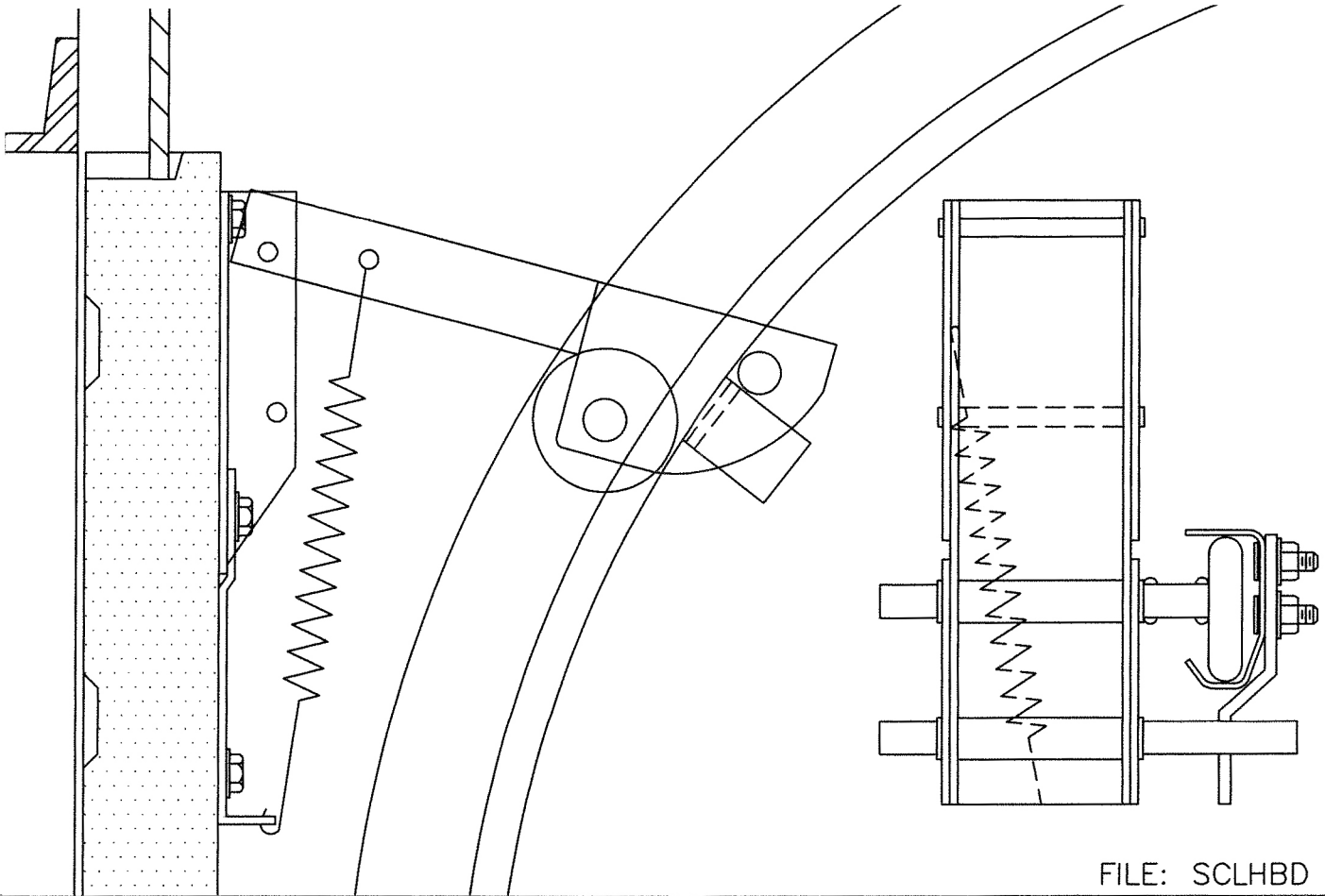

FILE: SCLHBD

### MINIMUM HEADROOM REQUIREMENT FOR THE SC LOW HEADROOM DEVICE

TRACK	RADIUS	BEARING PLATE	NORMAL	SC DEVICE	CUT MAX.
3"	15"	5"	18 3/4"	14 3/4"	4"
3"	15"	4"	17"	13"	4"
3"	15"	3"	14 3/4"	10 3/4"	4"
2"	15"	5"	17 1/4"	13 1/4"	4"
2"	15"	4"	15 3/4"	11 3/4"	4"
2"	15"	3"	13 1/2"	9 1/2"	4"
2"	12"	5"	15 1/4"	12 1/4"	3"
2"	12"	4"	14 1/4"	11 1/4"	3"
2"	12"	3"	12"	9"	3"