

I180SR - I400SR - I500SR - I180ER - I300ER - I500E
Surface mount or Mortice Stainless steel Electromagnetic Locks

Thank you for buying our products and for the confidence you placed in our company.

1] PRODUCT PRESENTATION

- **Stainless steel.**
- **Surface mounting or mortice**.**
- **Monitored**.**
- **Holding force: 180, 300, 400 or 500kg**.**
- **Security rope**.**
- **High corrosion resistance.**
- **Delivered with armature plate.**
- **No mechanical wear.**
- **Ease of installation.**
- **Recommended for outdoor use.**
- **Fail safe (Door unlocked when power off).**
- **Buit-in varistor: Electronic protection to eliminate back EMF.**

Refs	Holding force	Monitored
I180SR	180kg	✓
I400SR	400kg	✓
I500SR	500kg	✓
I180ER	180kg	✓
I300ER	300kg	✓
I500E	500kg	-

- Electromagnetic lock dimensions (L x W x D):
 - I180SR = 175 x 32,5 x 22mm,
 - I400SR = 230 x 43,5 x 29,5mm,
 - I500SR = 230 x 61 x 41mm.
 - I180ER = 201 x 32 x 22mm,
 - I300ER = 228 x 38 x 27mm,
 - I500E = 288,5 x 64 x 37,5mm.
- Armature dimensions (l x w x d):
 - 180kg = 130 x 32 x 9mm,
 - 300kg = 185 x 38 x 11mm,
 - 400kg = 185 x 45 x 12mm,
 - 500kg = 185 x 60 x 12mm.
- Power supply: 12/24V dc.
- Power absorption:
 - 12 V DC = 550mA,
 - 24 V DC = 275mA.

 EC certification

 IP54

 WEEE

 RoHS

Recommended power supplies



2] REMINDERS AND RECOMMENDATIONS

The function of an electromagnetic lock is to ensure the locking of an access point. This document is a guide of installation which will allow you to secure the installation according to the characteristics of the product, the site and the environmental requirements.

APPROVAL RELATIVE TO EMERGENCY EXITS

In the case of an installation of electromagnetic lock on emergency exits, it is imperative to make sure that these exit points will be automatically free in case of fire alarm, to open in the event of a fire alarm to allow evacuation of the premises. The electromagnetic lock installed on emergency exits must be in accordance with the fire approval department (Ex: In France = NF 61-937).

For more information, visit www.devancocanada.com or call toll free at 855-931-3334

* Refer to limited lifetime warranty conditions.
 ** Depending on the version.

I180SR - I400SR - I500SR - I180ER - I300ER - I500E*Surface mount or Mortice Stainless steel Electromagnetic Locks***POWER SUPPLY**

An electromagnetic lock always operates in DC current, a very low safety voltage. The Diax® electromagnetic lock is recommended for use with power supplies manufactured by CDVI, however, other power supplies may be used on condition that they are of equivalent quality and characteristics rectified, filtered, regulated and protected by fuse in primary and secondary sectors.

MOUNTING RECOMMENDATIONS

- Define the level of security of the access.
- Determine the maximum strength of holding force to this level of security.
- Select the Diax® electromagnetic lock according to the environment, the inside, the outside, the climatic constraints, (For example: stainless steel dedicated to an outside use).
- Always install the electromagnetic lock on the secure side of the place to be secured.
- Indeed make sure that the frame and opening, receiving or supporting the electromagnetic lock, armature plate and their accessories, are solid and resistant to damage or wear over a period of time.
- Consider any bracketry required for the assembly according to the type of support receiving the electromagnetic lock and armature plate.
- Define the passage of cables to ensure the protection against the vandalism and the environmental requirements (in particular through flexible hoses of door, glands, gutters, cross cables, plastic tubes).

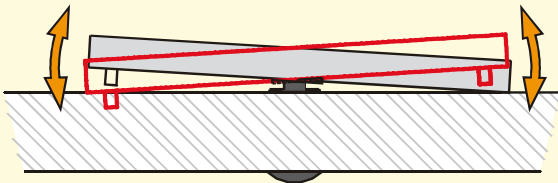
**Armature plate**

- It is vital to fix the electromagnetic lock and armature plate solidly on their supports.
- Make sure that the magnet and the armature meet evenly over their entire mating surfaces.
- The Armature plate must be able to pivot slightly about its center mounting screw to compensate for any door misalignment.

Security ropes

The electromagnetic lock undergoes repeated shocks and the vibration at the points of fixation on the frame (frequencies of openings / closures, attempt of opening wears closed and attempts of vandalism) which can loosen the fixing bolts/ screws. To prevent the risk of the electromagnetic block from falling, install both security ropes supplied, to guarantee the safety of the users (see attached plan).

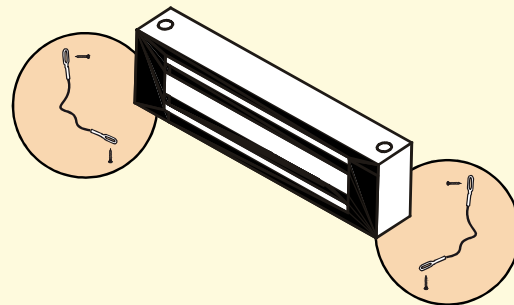







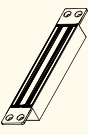
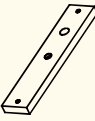

Security ropes
(fixing on the magnetic locks and to the frame)**MAINTENANCE**

The Electro magnet and armature plate have a specific treatment which strengthens the protection against wear and corrosion. These products do not require high maintenance. Nevertheless to ensure optimum performance, it is recommended to clean regularly the surfaces in contact of the electro magnet and armature plate with a cloth and non abrasive products. If traces of corrosion appear, it is recommended to clean and oil the contact surfaces. Check and tighten regularly all the fixings of the Electro magnet and ensure that while the armature is able to pivot on its mounting, the fixing bolt is not liable to loosen (we recommend thread-lock for all fixing bolts).

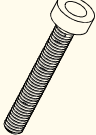



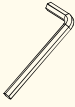

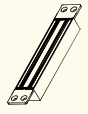
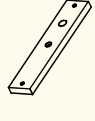

I180SR - I400SR - I500SR - I180ER - I300ER - I500E
 Surface mount or Mortice Stainless steel Electromagnetic Locks

3] PACKAGE CONTENTS







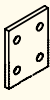
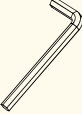
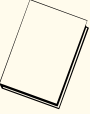

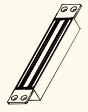

VERSION I180ER

								
Mortice magnetic lock	Armature plate	Stainless steel Screw 5x8	Cap nut	Guide piece	Stainless steel screw with rubber washer 5x35	Stainless steel Roll pin 5x16	Stainless steel washer 6x13	Rubber washer 6x10
1	1	8	1	1	1	2	2	1
								
Joggle bracket	3mm key	Installation Manual						
2	1	1						

VERSION I300ER

											
Mortice magnetic lock	Armature plate	Stainless steel Screw 5x8	Cap nut	Guide piece	Stainless steel screw with rubber washer 8x25	Stainless steel Roll pin 5x16	Stainless steel washer 10x22	Rubber washer 9x15	Joggle bracket	5mm key	Installation Manual
1	1	8	1	1	1	2	2	1	2	1	1

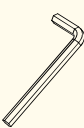









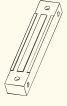
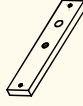

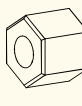

VERSION I500E

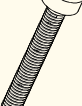
										
Mortice magnetic lock	Armature plate	Stainless steel Screw 5x8	Cap nut	Guide piece	Stainless steel screw with rubber washer 8x25	Stainless steel Roll pin 5x16	Stainless steel washer 10x22	Rubber washer 9x15	5mm key	Installation Manual
1	1	8	1	1	1	2	2	1	1	1

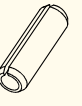



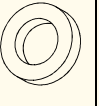
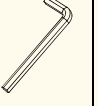
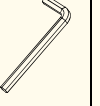
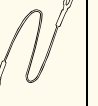





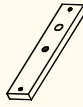

I180SR - I400SR - I500SR - I180ER - I300ER - I500E

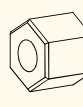
Surface mount or Mortice Stainless steel Electromagnetic Locks

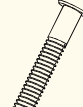
VERSION I180SR

											
Surface mount magnetic lock	Armature plate	Fixing plate	Stainless steel screw 3x10 (security ropes)	Cap nut	Guide piece	Steel screw nut 6x11	Seal up anchor	black steel screw 5x35	Stainless steel screw 5x35	Stainless steel screw with rubber washer 5x35	Stainless steel Roll pin 5x16
1	1	1	2	1	1	1	4	1	2	1	2
											
Stainless steel Strut 10x15	Stainless steel washer 6x13	Hole cover plate	Rubber washer 6x10	3mm key	4mm key	Security rope	Installation Manual				
2	2	4	1	1	1	2	1				

I400SR - I500SR

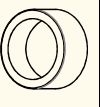
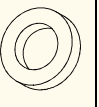
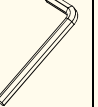
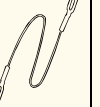
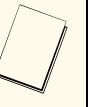
											
Surface mount magnetic lock	Armature plate	Stainless steel screw 3x10 (security ropes)	Cap nut	Guide piece	Steel screw nut 6x11	Seal up anchor	black steel screw 6x35	Stainless steel screw 6x40	Stainless steel screw 6x50	Stainless steel screw with rubber washer 8x35	Stainless steel Roll pin 5x16
1	1	2	1	1	1	4	1	2	2	1	2
											
Stainless steel washer 10x22	Stainless steel Strut 10x15	Hole cover plate	Rubber washer 9x15	5mm key	Security rope	Installation Manual					
2	2	4	1	1	2	1					

I180SR - I400SR - I500SR - I180ER - I300ER - I500E
 Surface mount or Mortice Stainless steel Electromagnetic Locks

4] OPTIONAL ACCESSORIES (ONLY FOR ARMATURE PLATE)

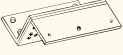
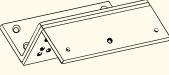
	SURFACE MOUNT	
		
References	Z1	Z3Z4Z5
Description	"Z" bracket for 180kg	"Z" bracket for 300, 400 and 500kg

5] ELECTRICAL CONNECTIONS

Terminal block	Correspondence	I500E	I180ER - I180SR I300ER - I400SR I500SR
+	12 or 24V dc	■	■
-	- 0 V	■	■
N.C	NC (Normally closed)	-	■
COM	COM	-	■
N.O	NO (Normally open)	-	■

The NO/NC signal only switches when the door is closed with the power to it on.

IMPORTANT NOTE

 **12V dc factory setup**

Check the jumper position before connecting the lock to the input current. A wrong position could damage the lock. This type of damage is not covered by the warranty.

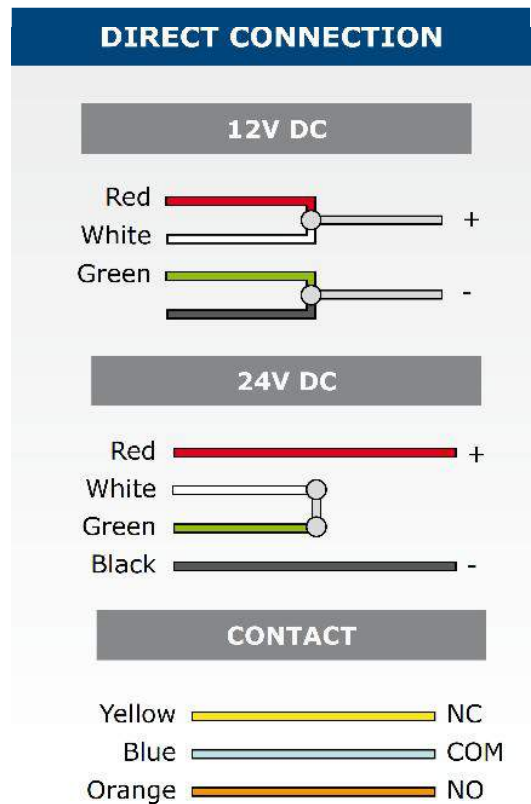
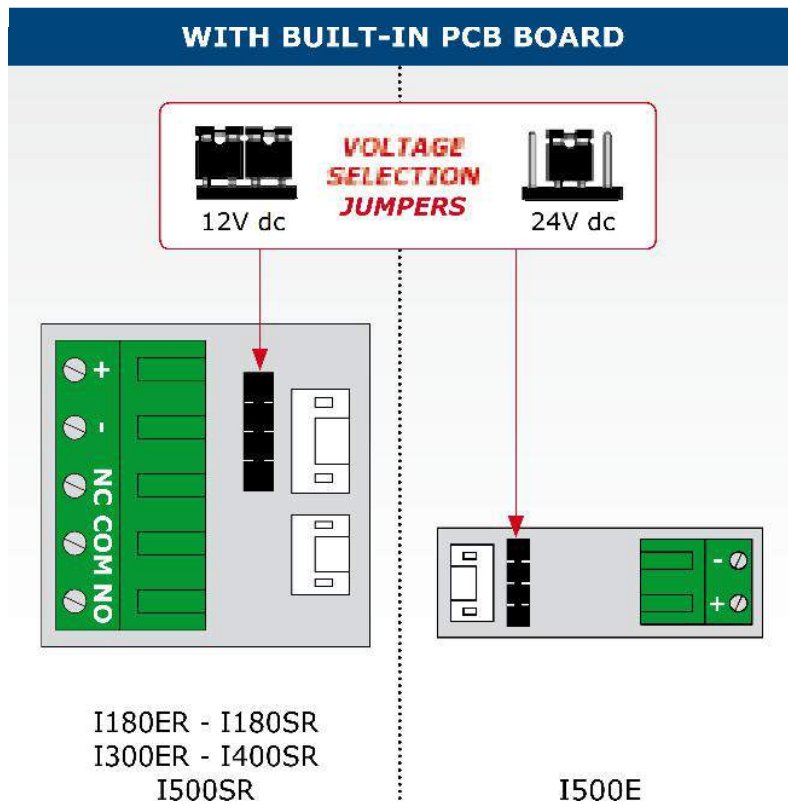

I180SR - I400SR - I500SR - I180ER - I300ER - I500E

Surface mount or Mortice Stainless steel Electromagnetic Locks

6] INSTALLATION

SURFACE MOUNT VERSIONS: I180SR - I300SR - I400SR - I500SR

Seal up anchor mounting

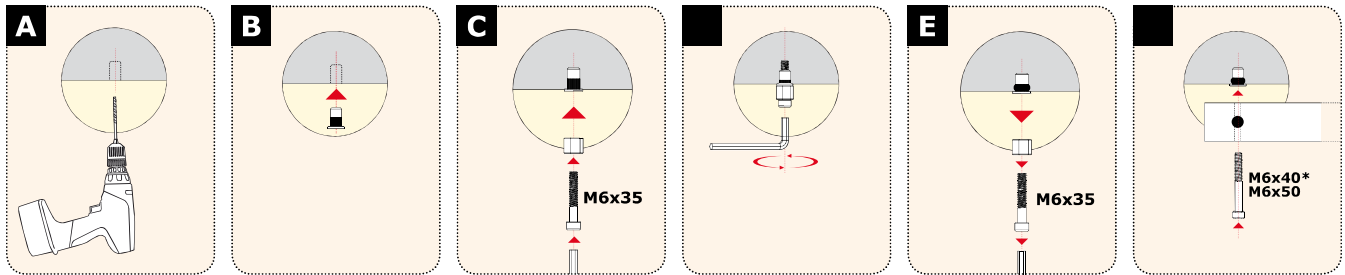

*According versions.

Surface mount electromagnetic lock mounting

VERTICAL MOUNTING

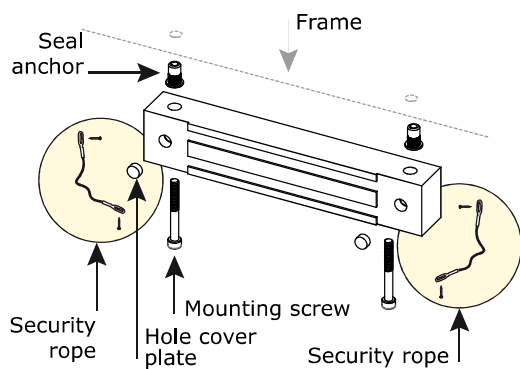

FRONT MOUNTING

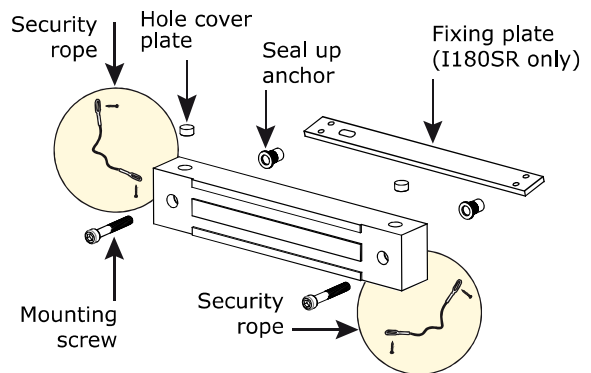

Installation on an outward opening door (Push door)

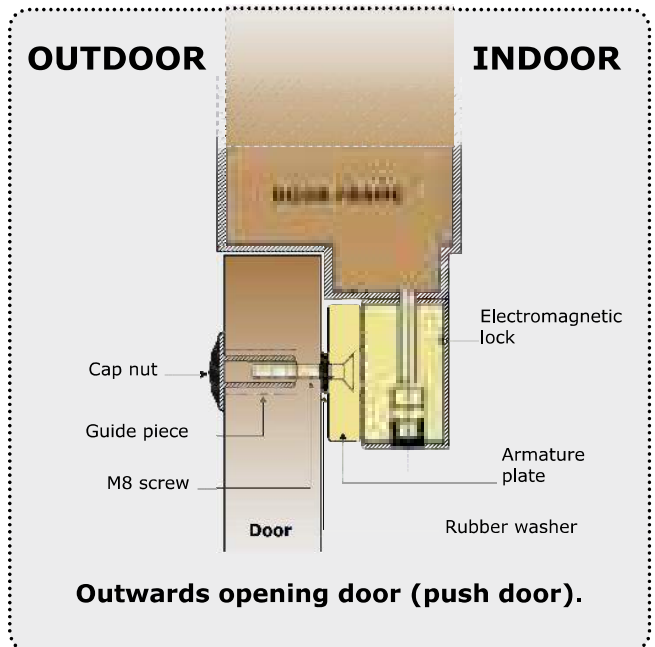
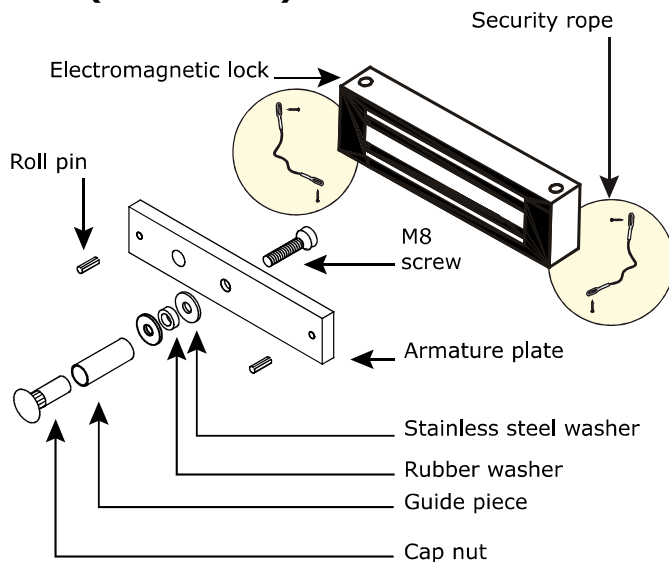

I180SR - I400SR - I500SR - I180ER - I300ER - I500E
 Surface mount or Mortice Stainless steel Electromagnetic Locks

Installation on an inward opening door (Pull door)

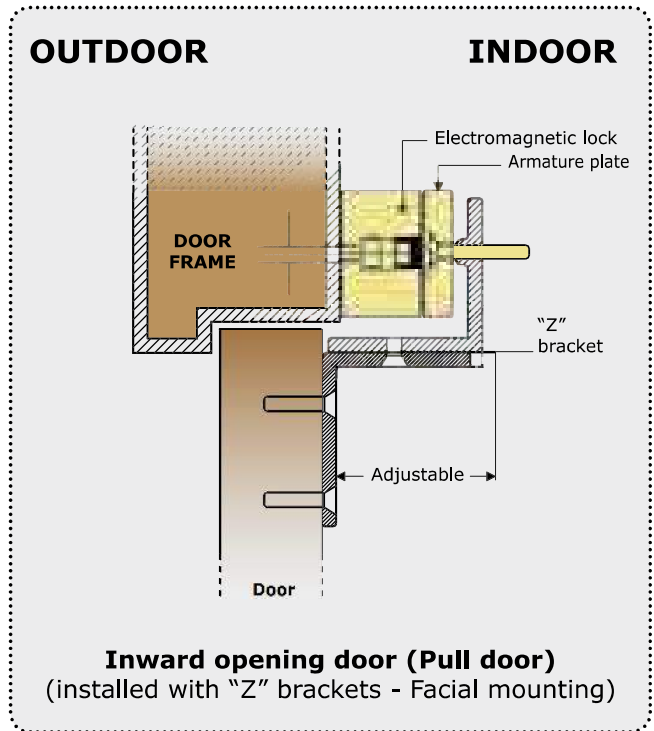
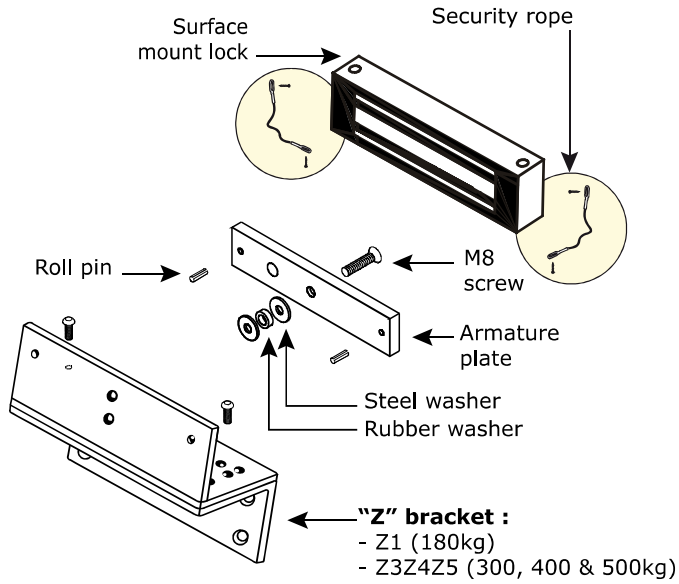

MORTICE VERSIONS: I180ER - I300ER - I500E

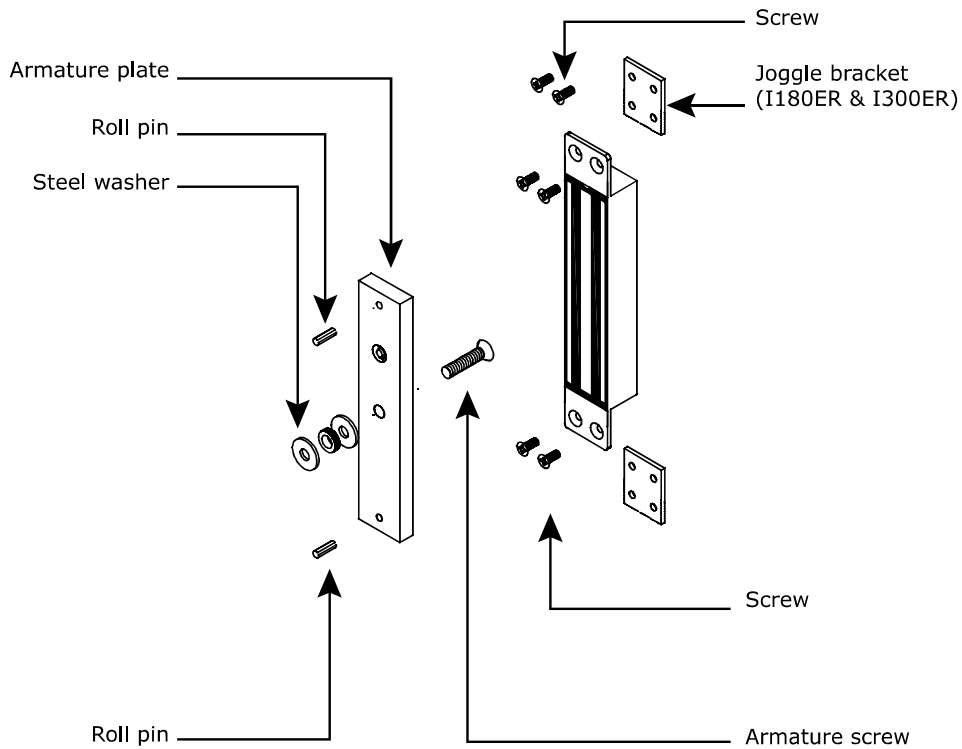

I180SR - I400SR - I500SR - I180ER - I300ER - I500E
Surface mount or Mortice Stainless steel Electromagnetic Locks

7] FAULT FINDING

PROBLEM	POSSIBLE CAUSE	SOLUTION
Door locking impossible	The lock is not receiving DC current.	<ul style="list-style-type: none"> - Check that the wires are connected to the right terminals. - Check that the power supply is compatible. - Check that the lock is connected to the circuit correctly.
Holding force reduced	The lock and the armature are not lined up with each other.	<ul style="list-style-type: none"> - Check that the lock is connected to the circuit correctly. - Check that the electromagnet and the armature are properly aligned. - Check that the contact faces are free from dirt and rust. - Check that the armature is soft mounted.
	Low voltage or armature jammed.	<ul style="list-style-type: none"> - Check that the lock is receiving the correct power supply satisfactorily. - check the tightening of the armature and the condition of the rubber.
Faulty reed switch	Voltage too low. Misalignment.	<ul style="list-style-type: none"> - Check the power supply. - Cable cross section to be determined according to the power supply and the locking. - e.g.: $2 \times 1.5\text{mm}^2 \geq 10\text{m}$.

8] LIMITED LIFETIME WARRANTY [EXTRACT]*

CDVI warrants this product to be free from defects in material and workmanship, when it has been installed in accordance with the manufacturer’s instructions and has not been modified or tampered with. Only product recognized by CDVI to be defective should be returned under these warranty terms if accompanied by an RMA (Return Material Authorization Number) provided by CDVI. CDVI, at its option, shall repair or replace the defective product at CDVI premises or at any CDVI approved service center. This warranty does not cover any damage due to accident, misuse, abuse or negligence. This warranty is valid only if the product is registered, within 1 month from delivery to the final customer. To obtain full details of this warranty and to register the product to commence the “Limited Lifetime Warranty”, complete the enclosed registration card and return it, either by e-mail or post, to the relevant CDVI address or completion of the on line registration at www.cdvigroup.com. Repair or replacement of the defective product is the exclusive remedy. CDVI shall not be liable for any incidental or consequential damages arising from any defect in, or malfunction of, its product. In no event the entire liability can not exceed the purchase price of the product. The CDVI local country contact details can be found on line by visiting www.cdvigroup.com or on the back cover of the installation manual.

DISCLAIMER OF WARRANTY: EXCEPT AS STATED ABOVE, CDVI MAKES NO WARRANTIES, EITHER EXPRESS OR IMPLIED, AS TO ANY MATTER WHATSOEVER, INCLUDING THE CONDITION OF ITS PRODUCTS, THE TRANSPORTATION, THEIR MERCHANTABILITY OR FITNESS FOR ANY PARTICULAR PURPOSE.

* Refer to complete limited lifetime warranty on [cdvigroup](http://cdvigroup.com) website.