

Pro-H/J

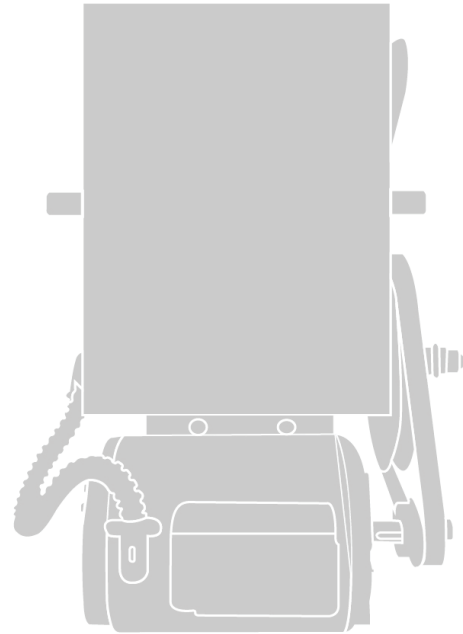

Automation for sectional and rolling doors

Instructions and warnings for installation and use

**For more information, please visit www.devancocanada.com or
call toll free at 1-855-931-3334**

Nice

Contents

| | |
|---|-----------|
| Warranty | 3 |
| Maximum Door Size & Door Type | 3 |
| Verification of Operator and Hardware | 4 |
| PRO-H, PRO-J Specifications | 5 |
| Important Safety Instructions | 6 |
| Important Installation Instructions | 6 |
| Installation Instructions | 7 |
| Electrical Connections | 10 |
| SECTION A: PRO-J, PRO-H Standard Relay Logic Controls | 11 |
| Connection of Power Supply and Control Station | 11 |
| Limit Switch Adjustment | 11 |
| Connection of a Reversing Edge Device and Control Accessories | 12 |
| SECTION B: PRO-J(M), PRO-H(M) Relay Logic Controls with Interface Module | 13 |
| Connection of Power Supply and Control Station | 13 |
| Operator Electrical Connections and Start-up Instructions | 13 |
| Important: Follow these steps carefully and in the order shown: | 13 |
| SECTION C: PRO-J(E): PRO-H(E) Full Feature Logic Board Smart 10.0 | 16 |
| Connection of External Single-Button Device | 18 |
| Modes of Operation | 18 |
| Programming Instructions | 20 |
| Run-Timer Setup | 20 |
| Mid-Stop Setup | 21 |
| Timer to Close Setup | 21 |
| Delay on Close Setup (only for use with optional apartment board) | 21 |
| On-Board Receiver Programming | 21 |
| Installing the Antenna | 21 |
| Programming the On-Board Radio Receiver | 22 |
| Operation | 22 |
| To Erase all Learned Transmitters | 22 |
| Replacing Remote Control Batteries | 22 |
| Dip-Switch Setup | 23 |
| SECTION D: For all Operator Control Types | 24 |
| Limit Switch Adjustment | 24 |
| SECTION E: For Operators with Interface Modules or Logic boards | 25 |
| Installation of Nice N-1 or N-4 Photocells | 25 |
| Installation Safety Precautions | 25 |
| Wall installations | 25 |
| NICE N-4 Photocell (MK00650) | 26 |
| Wall installation | 26 |
| For Nice Nema-1 and Nema-4 photobeams: | 27 |
| FRABA N-4/4 Thru-Beam Photocell (MK00697) | 28 |
| Clutch Adjustment | 29 |
| Installation Safety Precautions | 29 |
| Brake Adjustment (For Pro-JB or HB Models) | 29 |
| Emergency Manual Operation | 30 |
| Operator Maintenance | 31 |
| Jackshaft Operator Pro-J / Pro-JB Diagram | 32 |
| Jackshaft Operator Pro-J / Pro-JB Parts List | 33 |
| Jackshaft Operator Pro-H / Pro-HB Diagram | 35 |
| Jackshaft Operator Pro-H / Pro-HB Parts List | 36 |
| MS-100-IM-WW 1-Phase Wiring Diagram | 38 |
| MSL100-110V-WW 1-Phase Wiring Diagram | 39 |
| MS300-WW 3-Phase Wiring Diagram | 40 |
| MS300-IM-WW 3-Phase Wiring Diagram | 41 |
| MSL300-WW 3-Phase Wiring Diagram | 42 |
| MSLC300-WW 3-Phase Wiring Diagram | 43 |

Warranty

NICE NORTH AMERICA warrants that materials and workmanship are free from defects for a period of four (4) years or 100,000 cycles, whichever comes first. The start of the warranty will be determined by the date of invoice. Materials returned to Nice deemed defective after examination will be returned at the option of Nice with repaired, new, or re-manufactured parts.

NICE NORTH AMERICA will not be responsible for any charges incurred in the process of returning defective material. All returned material must be received pre-paid, or it will not be accepted.

This warranty is limited, and in lieu of all other warranties expressed or implied. There is no expressed liability due on the part of the seller.

Maximum Door Size & Door Type

| | | Sectional Doors | | | | | | Rolling Doors | | | | | | | |
|----------------------|----------------------------|-------------------|-------------------------|----------------|------------|------|------|---------------|------|-----------------|----------------|------|-----|-----|-----|
| Uninsulated Steel | | 24ga | 22ga | 20ga | 18ga | 16ga | | 24ga | 22ga | 20ga | 18ga | 16ga | | | |
| Insulated Steel | | | | 24ga | 22ga | 20ga | 16ga | | | | | | | | |
| Other | | Fiberglass | | Aluminum Doors | Wood Doors | | | | | Aluminum Grills | Aluminum Doors | | | | |
| Model | | HP | Maximum Sq. Feet | | | | | | | | | | | | |
| Belt Drive Jackshaft | Continuous Duty Commercial | PRO-J, EJ, H, EHJ | 1/2HP | 390 | 365 | 330 | 305 | 280 | 230 | 200 | 390 | 350 | 260 | 240 | 190 |
| | | | 3/4HP | 520 | 500 | 500 | 450 | 365 | 325 | 275 | 540 | 450 | 370 | 300 | 240 |
| | | | 1HP | 625 | 605 | 550 | 500 | 445 | 400 | 310 | 625 | 525 | 400 | 360 | 300 |

| | |
|--------------------|--|
| MP00046 | #60 Drive Chain and Sprockets |
| MP00081 | Double V-belt reduction |
| MP00024 | Chain Spreader 1" - 1" |
| MP00025 | Chain Spreader 1" - 1-1/4" |
| MP00040 | High Cycle Modification |
| PRO-_W | Waterproof Modification |
| PRO-_4X | Corrosion Proof Modification |
| PRO-_X | Explosion Proof Modification |
| MP00007* | 115 Volt Control Circuit |
| MP00061** | 1.5 Sec Time Delay on Reverse |
| MP00001** | Timer to Close |
| PRO-PL | Separate Control Panel |
| MP00038 | Fire Release Mechanism |
| MP00028 | Hand Crank |
| 9999999 | Pusher Springs |
| MP00069-74 | Auxiliary Trolley C/W Track & #41 Chain |
| MP00012-118 | Dual Auxiliary Trolley C/W Track & #41 Chain |
| MX00001 | Floor Level Disconnect in Lieu of Chain Keeper |

* Not available for logic board controls

** Standard feature with logic board controls

⚠ **WARNING** ⚠

DO NOT CONNECT TO ELECTRICAL POWER DURING
INSTALLATION OR SERVICING OF OPERATOR.

IMPORTANT

FOR ANY QUESTIONS CONCERNING THE SAFETY OR OPERATION OF THIS OPERATOR, PLEASE CONTACT NICE AT 1-877-888-1116. SAVE THESE INSTRUCTIONS.

Verification of Operator and Hardware

Upon delivery of your Nice heavy-duty jackshaft door operator, please inspect the unit carefully for damage. Verify that operator control wiring option, HP, voltage, phase and amperage correspond to available power supply and door application. Check that along with your operator you have received the following standard hardware.

1 x OPEN/CLOSE/STOP 3-Button Control Station

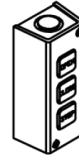

1 x #50 Drive chain package: 4' (1.2m) c/w #50 connecting link

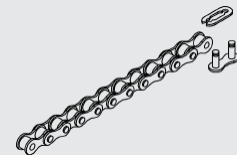

1 x Drive Sprocket 50B12 x 1" c/w 2 set screws and 1/4" x 1-1/4" keyway



1 x Door Sprocket 5018 x 1" c/w 2 set screws and 1/4" x 1-1/4" keyway.

NOTE: Sprocket size and bore may vary according to door size and type, shaft size and drum diameter.



1 x Chain Keeper

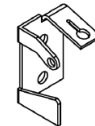

1 x Keyring



4 x 3/8" bolt, hex nut, lock washer and flat washer



1 x pocket wheel hand chain (Model PRO-H) 2 x door height less 4' (1.2m)



1 x Warning Sign



1 set of Nice photocells (supplied when operator ordered with interface module or logic board controls)

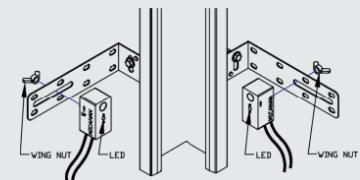

PRO-H, PRO-J Specifications

PRO-J and PRO-H heavy-duty jackshaft operators are designed for commercial and industrial high lift, vertical lift, rolling doors and rolling grilles provided that doors are driven by a drive shaft. Model PRO-H is essentially the same as model PRO-J with the exception that the PRO-H operator incorporates a chain hoist for manual operation of the door.

| | | | |
|----------------------------------|--|---------------------|---------------------|
| Standard Operator Weight: | 70-95 LBS | | |
| Motor: | <ul style="list-style-type: none"> Continuous duty 1725 RPM industrial type motor. (NOTE: 1450 RPM for 50Hz motors) Built-in overload protection (3-phase) or separate full overload protection (1-phase) | | |
| Horsepower | 1/2HP | 3/4HP | 1HP |
| Voltage | 115V 1-phase (60Hz) | 230V 3-phase (60Hz) | 220V 1-phase (50Hz) |
| | 230V 1-phase (60Hz) | 460V 3-phase (60Hz) | 380V 1-phase (50Hz) |
| | | 575V 3-phase (60Hz) | |
| Reduction: | Primary: (5L) V-belt and pulleys (2" to 8" diameter). Secondary: #41 chain and sprockets | | |
| Output Shaft Speed: | 36 RPM | | |
| Brake (Optional): | Solenoid actuated drum and brake shoe braking system to prevent coasting and maintain door position. | | |
| Wiring Type (3 Options): | <p>Option 1: Full Feature logic board Smart 10.0 [UL325(2010) compliant]. NOTE: Nice compatible primary entrapment device must be connected for B2, T or TS (momentary or timer activation on close) feature.</p> <p>Option 2: Relay logic controls with Interface Module [UL325(2010) compliant]. C2 Standard factory wiring (constant pressure on close, momentary contact on open and stop). If momentary contact on close (B2) wiring is desired, move "white" wire from terminal #6 to terminal #3. NOTE: Nice compatible primary entrapment device must be connected for B2 (momentary activation on close) or for T (timer to close) feature.</p> <p>Option 3: Standard relay logic controls (not [UL325(2010) compliant], not available in US or Canada). C-2 Wiring constant pressure on close, momentary contact on open and stop. NOTE: If momentary contact on close (B2) wiring is desired, move "white" wire from terminal #5 to terminal #3.</p> | | |
| Transformer: | 24VAC control circuit, supplies power to drive logic board or control relays with 15VA power available for external devices. | | |
| Limit Adjustment: | 4 micro switches that control door travel. These limit switches are activated by fully adjustable screw type cams. | | |
| Emergency Disconnect: | Floor level cable disconnect system with electrical cut-out feature allows person to manually operate the door by hand (PRO-J) or by chain hoist (PRO-H) in case of emergency. | | |
| Clutch: | Adjustable friction clutch to minimize damage to door operator, door or vehicles when obstruction occurs. | | |

Operator Dimensions:

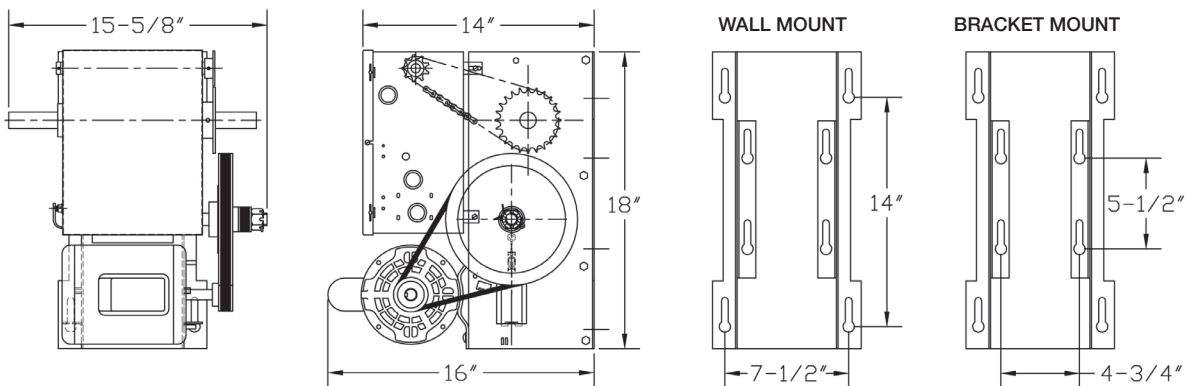

Important Safety Instructions

WARNING: To reduce the risk of injury or death:

- READ AND FOLLOW ALL INSTRUCTIONS
- Never allow children to operate or play with door controls. Keep the remote control (where provided) away from children.
- Personnel should keep away from a door in motion and keep the moving door in sight until it is completely closed or opened. **NO ONE SHOULD CROSS THE PATH OF A MOVING DOOR.**
- Test the door's safety features at least once a month. After adjusting the limit of travel, retest the door operator's safety features. Failure to adjust the operator properly may cause severe injury or death.
- For products having a manual release, if possible, use the manual release only when the door is closed. Use caution when using this release when the door is open. Weak or broken springs may cause the door to fall rapidly, causing severe injury or death.
- **KEEP DOORS PROPERLY OPERATING AND BALANCED.** See Door Manufacturer's Owner's Manual. An improperly operating or balanced door could cause severe injury or death. Have trained door systems technician make repairs to cables, spring assemblies, and other hardware.
- Press the "OPEN" device or use emergency disconnect mechanism if a person is trapped under the door.
- **SAVE THESE INSTRUCTIONS.** The owner or users must understand the safety and operation of door system. Insure that this installation manual be located close to the door system.

Important Installation Instructions

- READ AND FOLLOW ALL INSTALLATION INSTRUCTIONS
- Commercial door operators are never to be installed on a residential installation
- Install only on a properly operating and balanced door. A door that is operating improperly could cause severe injury. Have qualified service personnel make repairs to cables, spring assemblies, and other hardware before installing the operator.
- Remove all pull ropes and remove, or make inoperative, all locks (unless mechanically and/or electrically interlocked to the power unit) that are connected to the door before installing the operator.
- Install the door operator at least 8 feet or more above the floor if the operator has exposed moving parts.
- Do not connect the operator to the source of power until instructed to do so.
- Locate the control station: (a) within sight of the door, (b) at a minimum height of 5 feet so that small children cannot reach it, and (c) away from all moving parts of the door.
- Install the Entrapment Warning Placard next to the control station in a prominent location.
- For products having a manual release, instruct the end user on the operation of the manual release.
- Install non-contact entrapment protection devices (photocells) and/or contact entrapment protection devices (reversing edges). **NOTE:** photocells should be installed at no more than 6" from the floor. Edges should be installed on the leading edge of the door.

Installation Instructions

⚠ WARNING ⚠

DO NOT INSTALL THIS OPERATOR BEFORE READING THIS MANUAL CAREFULLY.

NOTE:

- Installation of operator must be done by a qualified installer. Door must be properly installed and working smoothly. Remove all door locks prior to installation.
- The PRO-J and PRO-H operators have dual output shafts and may be mounted on left (standard) or right hand side of door. If handing of operator must be reversed, loosen set screws, remove drive sprocket and keyway and install on opposite side of drive shaft.

LEFT HAND

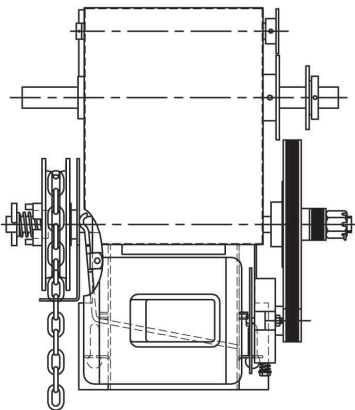

RIGHT HAND

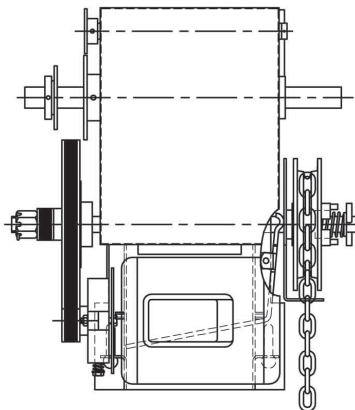

SWITCHING HANDING

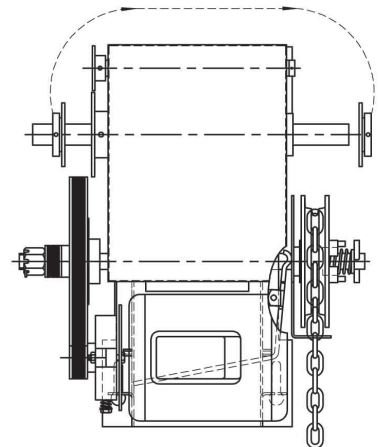

For the PRO-H operator which incorporates a chain hoist mechanism the handing of the operator must be stated at time of order. Depending on installation, if handing of chain hoist is not correct the hand chain may hang in door opening. If this is the case, swing chain off to the side and hook it over the top of the door jamb. Do not attempt to reverse chain hoist on site.

1. Install control station away from all moving door parts, within sight of the door and a minimum of 5 ft (1.5 m) from the ground.
2. Install entrapment warning sign next to control station.

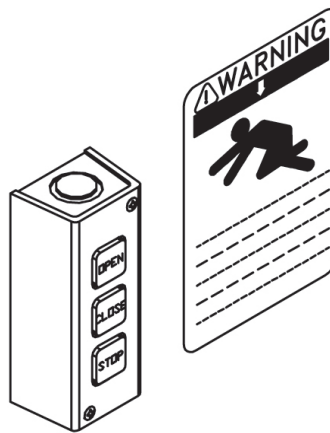

- As a general rule, the door operator should be installed below the drive shaft and as close to the door as possible. The ideal distance between the operator drive shaft and the door shaft is approximately 12" (30cm) to 15" (38cm). The operator may be wall/bench mounted or bracket/shelf mounted. These two mounting configurations are shown below:

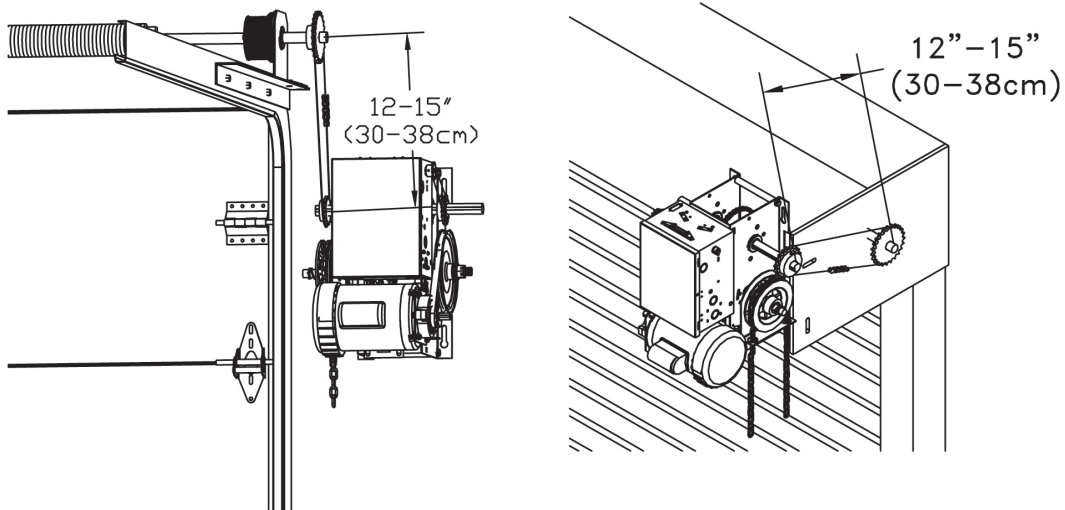

- Mount the operator to the wall, hood or bench with 3/8" bolts, nuts and washers provided or with lag bolts and shields if installation requires it. Make sure that operator is secured but do not tighten bolts.
- Place door sprocket on door shaft and align with operator drive sprocket but do not insert keyway or set screws.
- If an optional chain spreader has been ordered with your operator, install as shown below:

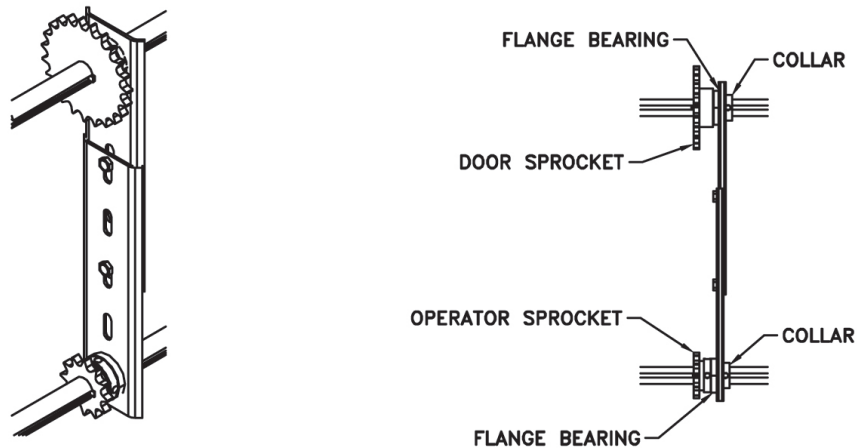

- Install drive chain over sprockets, cut to a suitable length and connect with connecting link.
- Lower or raise operator to adjust chain tension so that there is no more than 1/4" chain slack between sprockets. Tighten operator mounting bolts.
- Carefully re-align sprockets, if necessary and secure keyway and set screws.

10. For PRO-H models: Install hand chain by wrapping it through chain guard holes and pocket wheel. Allow chain to hang down towards floor. Cut chain and connect so that chain is 2' to 3' from the floor.
11. Install chain keeper to wall near hand chain at approximately 4' from floor. Run disconnect chain through keyhole of chain keeper and cut excess chain links if required. Attach keyring to end of disconnect chain.

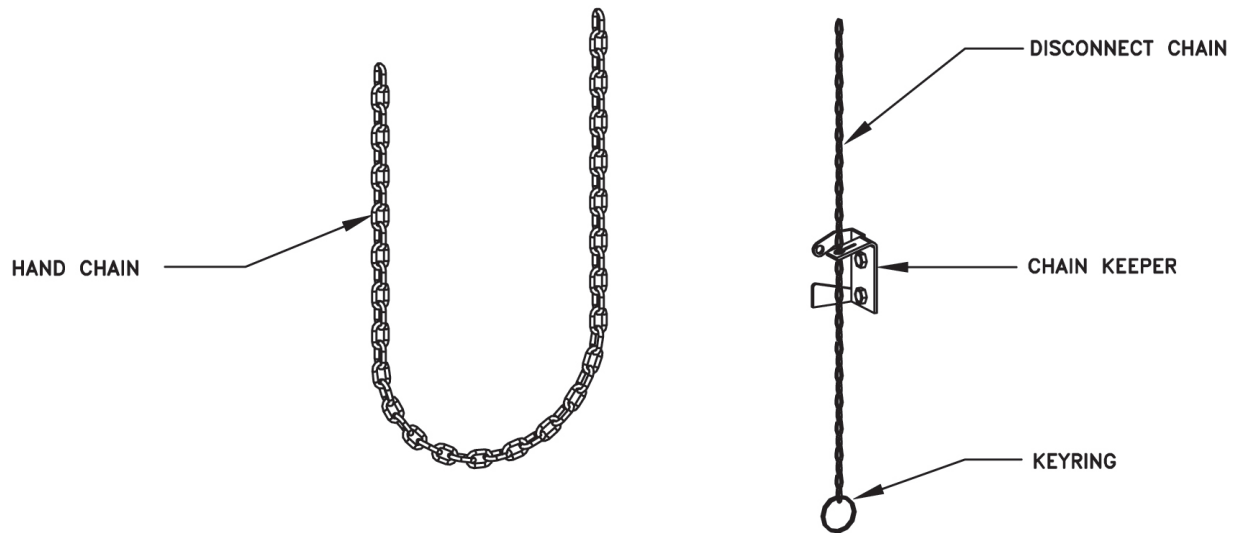

12. If an optional floor level disconnect lever was ordered in lieu of the chain keeper, mount to wall with suitable hardware. Attach both chains together using keyring provided. Allow disconnect chain to be slightly slack when lever is in the up position.

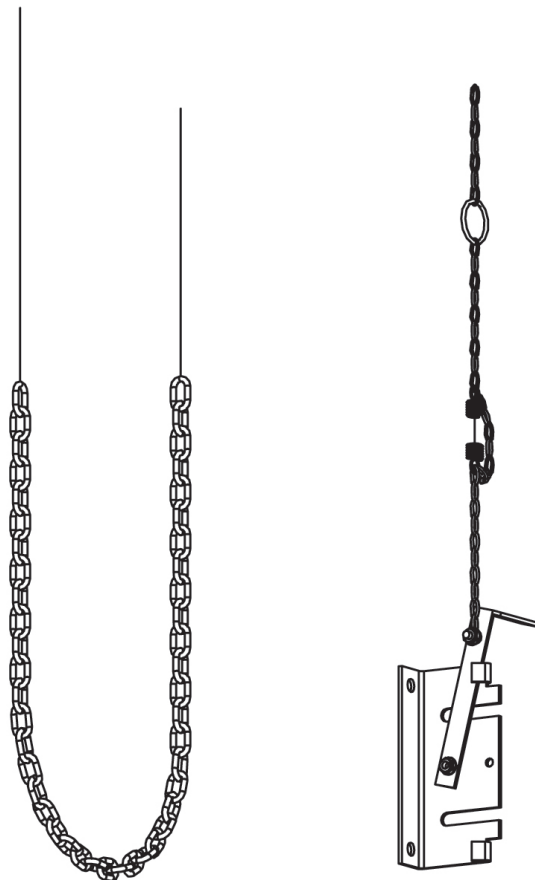

Electrical Connections

These are 3 possible electrical control configurations for this operator:

- A) Standard relay logic controls (not UL325 (2010) compliant, not available in US or Canada). Refer to Section A for electrical connections. Refer to electrical drawings inside your operator control box or generic drawings MS100-WW or MS300-WW in the electrical drawings section at the end of this manual.
- B) Relay logic controls with Interface Module (UL325 (2010) compliant). Refer to Section B for electrical connections. Refer to electrical drawings inside your operator control box or generic drawings MS100-IM- WW or MS300-IM-WW in the electrical drawings section at the end of this manual.
- C) Full Feature logic board Smart 10.0 (UL325 (2010) compliant). Refer to Section C for electrical Connections and logic board instructions. Refer to electrical drawings inside your operator control box or generic drawings MSL100-110V-WW, MSL300-WW, MSL300-WW or MSLC300-WW in the electrical drawings section at the end of this manual.

IMPORTANT

- EACH INDIVIDUAL COMMERCIAL DOOR OPERATOR MUST HAVE IT'S OWN DEDICATED POWER SUPPLY
- NICE HIGHLY RECOMMENDS THAT EACH INDIVIDUAL COMMERCIAL DOOR OPERATOR HAVE AN EXTERNAL CIRCUIT BREAKER OR FUSED DISCONNECT

⚠ WARNING ⚠

COMPARE AVAILABLE POWER SUPPLY VOLTAGE TO OPERATOR NAMEPLATE PRIOR TO ELECTRICAL CONNECTION. FAILURE TO CONNECT APPROPRIATE POWER SUPPLY VOLTAGE MAY CAUSE SERIOUS DAMAGE TO OPERATOR.

Refer to electrical diagrams inside control box cover or at the end of this manual prior to connection of power supply or control station.

⚠ WARNING ⚠

TO REDUCE THE RISK OF INJURY OR DEATH:
ALL ELECTRICAL CONNECTIONS SHOULD BE MADE BY A QUALIFIED SERVICE PERSON
DO NOT ATTEMPT TO MAKE ELECTRICAL CONNECTIONS TO OPERATOR UNLESS POWER SUPPLY HAS BEEN DISCONNECTED AT FUSE BOX.
OPERATOR MUST BE CONNECTED IN ACCORDANCE TO LOCAL ELECTRICAL CODES AND GROUNDED TO GREEN GROUND LUG LOCATED INSIDE CONTROL BOX.

SECTION A: PRO-J, PRO-H Standard Relay Logic Controls

(not UL325 (2010) Compliant, not available in US or Canada)

Connection of Power Supply and Control Station

POWER WIRING: Use 1-1/8" (2.85 cm) diameter holes for all power wiring.

1. Single phase: Connect single phase power supply to terminals L/L1 (line) and N/L2 on three-pole power terminal strip.
2. Three-phase: Connect three phase power supply to terminals L1, L2 and L3 on three-pole power terminal strip.

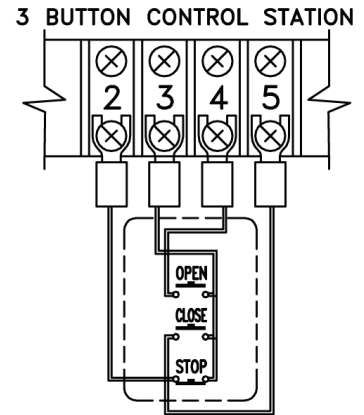
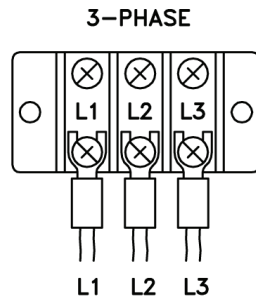
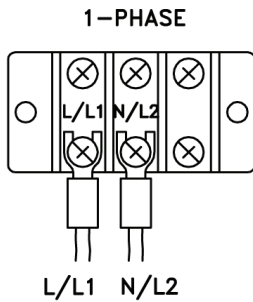

CONTROL WIRING: Use 7/8" (2.22 cm) diameter holes for all control wiring.

NOTE: Do not run control wires and power wires in same conduit.

- Install control station within clear sight of door but away from all moving parts of door or hardware. Install Entrapment warning sign next to control station. Connect 3-button (open/close/stop) push button station to terminals 2, 3, 4 and 5. Refer to electrical diagram for connection of two 3-button stations.

NOTE: After electrical connections are made, manually move door to mid-position and, using the control station press the "Open" button for several seconds and then press the "Stop" button. If door did not move in correct direction verify wiring control station. For 3-phase operators, if door still moves in wrong direction reverse any two of the three incoming power supply leads to correct rotation.

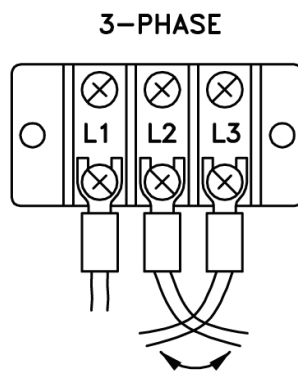

Limit Switch Adjustment

- Adjust Limit switches as explained in the "Limit switch adjustment section" further in this manual.

Connection of a Reversing Edge Device and Control Accessories

1. **Reversing Edge device** (must be normally open contact):

NOTE: If the door is controlled by any device or wired in such a manner that the door is not controlled by constant pressure on close then an appropriate reversing edge must be installed.

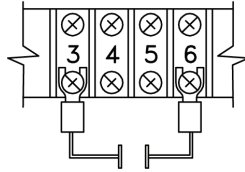

2. **External interlock:** Remove Jumper between terminals 1 and 2 and wire a N.C. interlock contact between these two terminals.

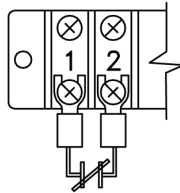

3. **Radio control receiver:** Wire standard radio receiver to separate radio strip on side of control box or to terminals 7, 8 and 9 on control terminal strip inside control box.

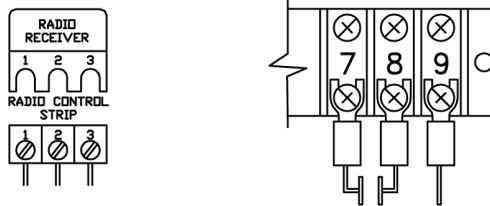

4. **Single button open/close device:** Wire to terminals 7 and 8 on control terminal strip.

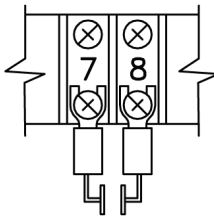

5. **Loop detectors, standard photocells (with a N.O. contact) and other reversing devices:** Wire to terminals 3 and 6 on control terminal strip.

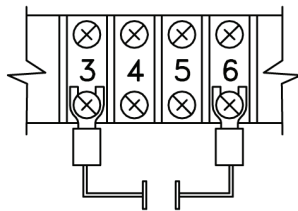

6. **24 Volt power:** Wire to terminals 1 and 9 on control terminal strip

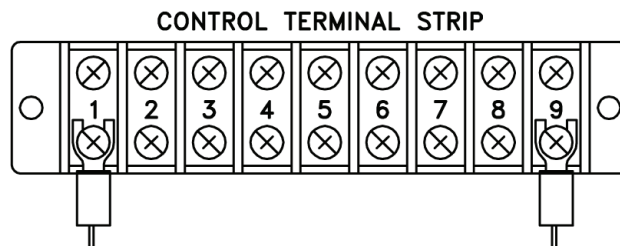

SECTION B: PRO-J(M), PRO-H(M) Relay Logic Controls with Interface Module

[UL325 (2010) Compliant]

Connection of Power Supply and Control Station

Operator Electrical Connections and Start-up Instructions

NOTE: THIS OPERATOR COMES WITH AN INTERFACE MODULE INTEGRATED INTO THE CONTROL CIRCUIT. THE PURPOSE OF THE INTERFACE MODULE IS TO ALLOW FOR FAILSAFE MONITORING OF A NICE COMPATIBLE SAFETY DEVICE AS PER UL 325 (2010) REQUIREMENTS.

Important: Follow these steps carefully and in the order shown:

1) Connect Power supply

Single Phase: Connect single phase power supply to terminals L/L1 and N/L2 on the 3-pole power terminals strip. **3-phase:** Connect 3-phase power supply to terminals L1, L2 and L3 on the 3-pole power terminal strip.

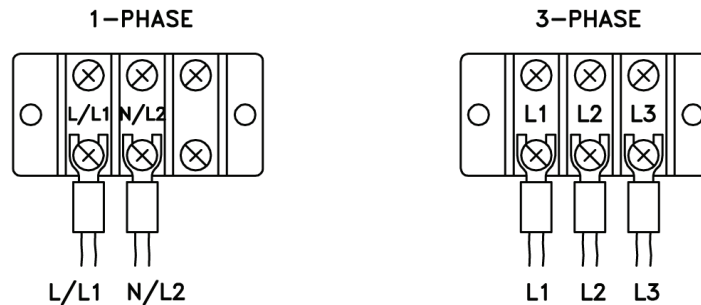

2) Connect Push-button station for installation purposes (single phase or 3-phase)

Connect open/close/stop push button station to terminals T2 (stop), T3 (common), T4 (open) and T6 (temporary CP on close).

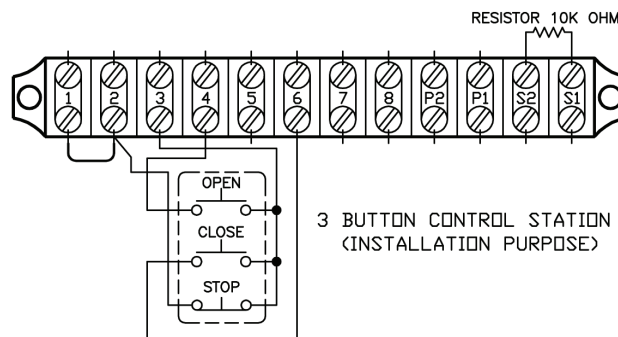

3) Verify Motor Direction

After the electrical power connections are made and push button station is connected, manually move the door to mid-position. Press Close button for several seconds and then press stop button. If door did not move in correct direction (or if limit cams not moving in correct direction towards the close limit switch) see below:

Single Phase Operators: The operators leave the factory with correct motor and limit shaft direction according to standard door installations. However, for special fire door, thru-wall mounting or other special door applications, the motor direction and limit switch direction may need to be reversed. To reverse the motor rotation, interchange black and white wires going to motor on the reversing contactor.

3-Phase Operators: If door moves in wrong direction, turn off incoming power and reverse any two of the three incoming power supply leads to correct rotation. Press the open button and then activate the open limit to ensure door stops. If door does not stop, interchange gray and red wires on open and close limits. Interchange white and gray wires on advanced open and advanced close limits. Remove blue wire from advanced open limit and place it on N.O. pin of advanced close limit.

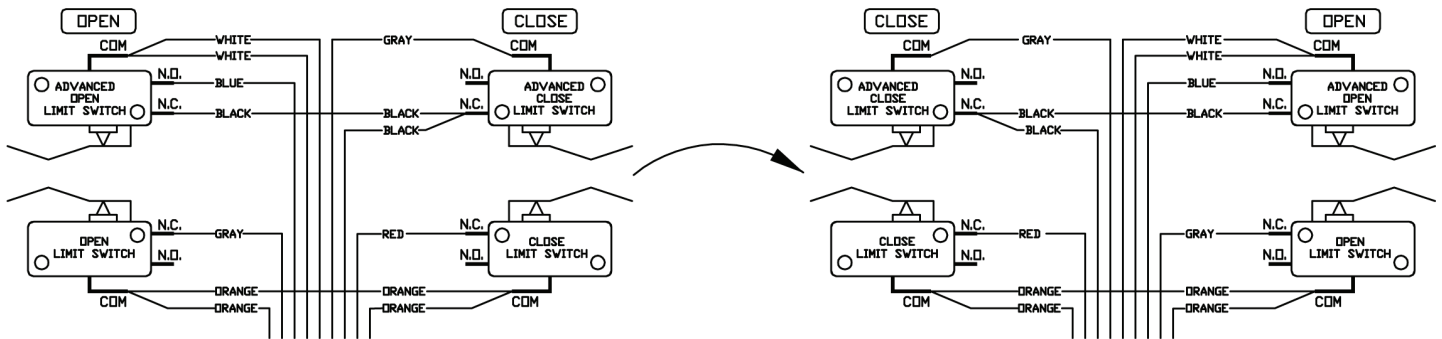

4) Adjust Limit Switch Cams

Using the open/close/stop push button station move door to fully closed and fully open positions and set limit cams to correct position. (See Limit adjustment section D further in this manual for complete detail on the end of travel limit adjustments).

5) Activate Interface Module

After adjusting the open and close limits and verifying the motor rotation, open the door to the full-open position using the open push button (Figure below on left).

At this point the close pushbutton wire must now be moved from terminal T6 to T5. Now connect the black wire (with blue label) to terminal T1 as shown in figure below on right.

NOTE: Ensure the door is in the full open position before connecting the black wire. If door is not in full open position and monitored photo-eyes or safety edge are not connected and operational then door will immediately move in the open direction.

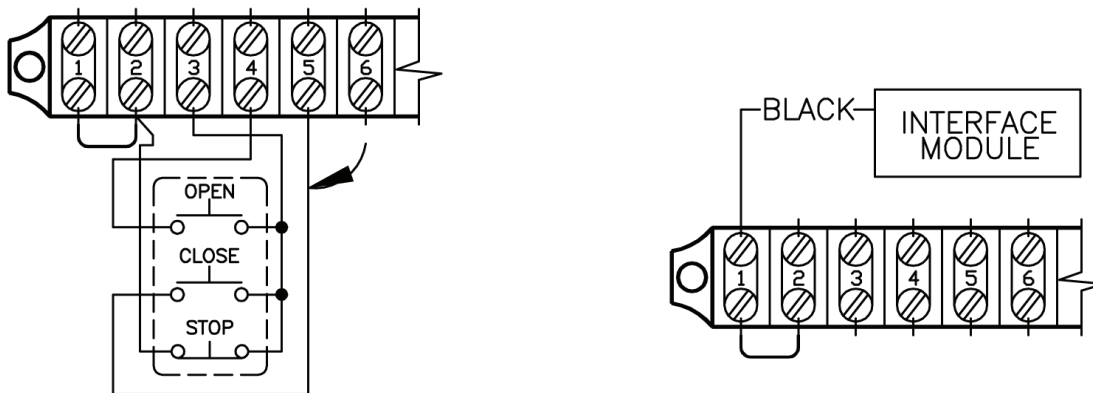

6) Connect Safety Devices

Failsafe Feature: A monitored failsafe safety feature is built into the operator. The operator has provisions to connect one primary monitored safety device as well as one or more non-monitored safety device(s).

Primary monitored safety device:

Nice monitored failsafe photo beams or Nice compatible monitored failsafe devices must be connected to terminals P1 and P2 if momentary close on pushbutton is required (B2 mode). If not connected, door can only be closed by constant pressure on close pushbutton. If constant pressure on close pushbutton is removed before door reaches full closed position, then door reverses to full open.

NOTE: Only one monitored failsafe safety device can be connected across terminals P1 and P2.

NOTE: See section E for complete installation instructions for the Nice N-1 or the Fraba photocells.

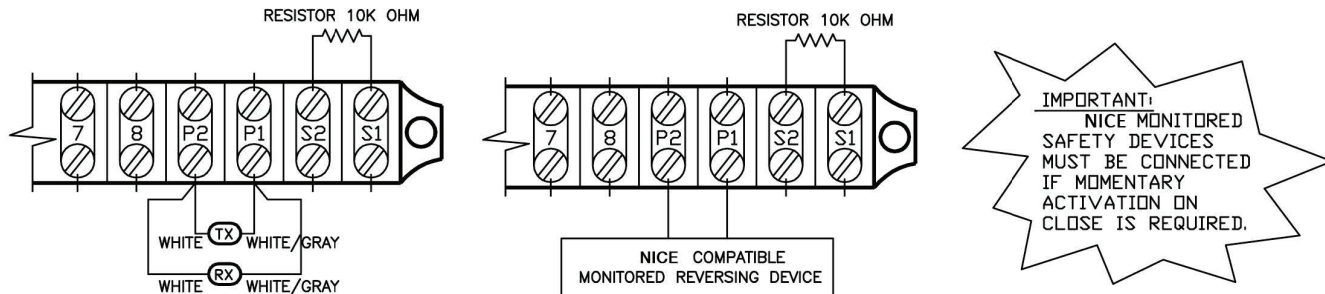

Secondary Non-Monitored Safety Device(s):

A standard 2-wire safety edge, non-monitored reflective or thru-beam photo eye or any other non-monitored reversing devices with a N.O dry contact can be connected to terminals S1 and S2.

NOTE: More than one secondary non-monitored safety device can be connected to terminals S1 and S2.

IMPORTANT: Do not remove resistor that is factory installed across terminals S1 and S2 unless installing a 4-wire electric edge.

4-Wire Electric Edge Connection

A standard 4-wire electric edge can be connected across S1 and S2 terminals as a secondary safety device. Remove the factory installed resistor across terminals S1 and S2, and install resistor across the black and white pair of wires from the electric edge and connect the remaining black and white wire to the S1 and S2 terminals.

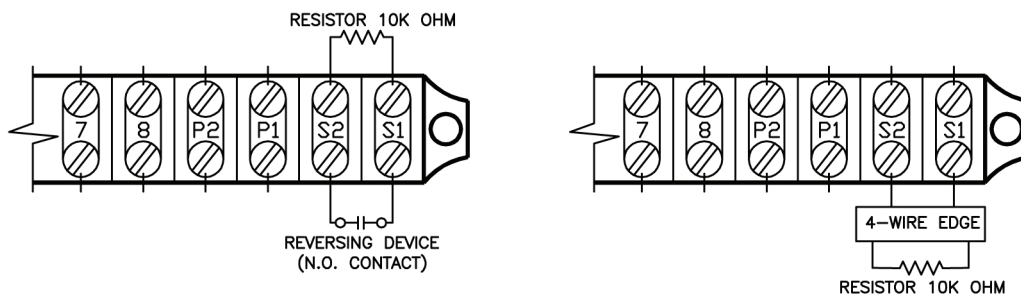

7) Select Mode of Operation

C2 mode of operation (momentary on open, constant pressure on close):

The operator is wired at the factory for momentary on open and constant pressure on close. For commercial operators, white wire is connected to terminal T6.

B2 mode of operation (momentary on open, momentary on close):

If momentary on close is required: For commercial operators, remove the white wire from terminal T6 and place it on terminal T3.

The operator functions in B2 mode only when the primary monitored safety device is connected and functioning properly. If it is not connected, operator will go into fault mode and door can only be closed by constant pressure on close and if constant pressure on close is removed before door reaches full close position, door reverses to full open.

SECTION C: PRO-J(E): PRO-H(E) Full Feature Logic Board Smart 10.0

[UL325 (2010) Compliant]

NOTE: The operator is shipped from the factory in the D1 mode setting (constant pressure open and close). The operator should remain in this mode until all connections and limit switch adjustments are completed.

Power Wiring Instructions

Connect primary power supply directly to the separate power terminal strip supplied using any of the 1-1/8" (2.85 cm) diameter holes provided on control box. Do not connect power supply directly to the circuit board.

Single Phase: Connect single-phase power supply to terminals L/L1 and N/L2 on three-pole power terminal strip (110V or 220V 1-phase).

Three-Phase: Connect three-phase power supply to terminals L1, L2 and L3 on three-pole power terminal strip (230V, 230V, 380V, 460V or 575V).

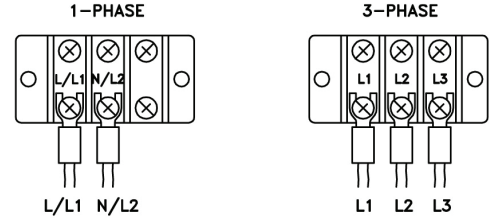

On Board O/C/S PBS Instructions

On-board Open, Close and Stop buttons are provided directly on the board for installation and troubleshooting purposes. In order to operate unit by on-board Open, Close, Stop buttons, the factory installed jumper (#1) between the COM and STOP terminals on the terminal strip must remain connected.

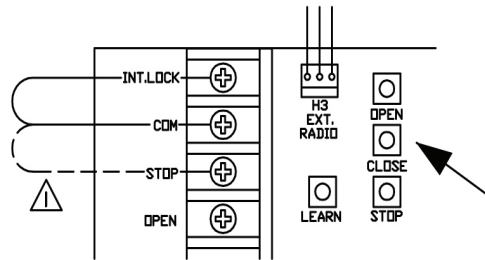

Motor Direction Verification

Make sure the mode of operation is selected to D1.

After electrical power connections are made, manually move door to mid-position. Using the on-board buttons press the "Open" button for several seconds and then press the "Stop" button. If door did not move in correct direction (or if limit cams not moving in correct direction towards the open limit switch) see below:

For Single-Phase Operators: The operators leave the factory with correct motor and limit shaft direction according to standard door installations. However, for special fire door, through wall mounting or other special door applications, the motor direction and limit switch direction may need to be reversed. A dipswitch (Dip #1) is provided to reverse direction of motor and limit switch direction. If motor direction is reversed, the open and close limit switches are automatically reversed. However, the advanced close limit switch needs to be manually changed. Disconnect the 2 wires from the advanced closed limit switch and re-connect to the auxiliary limit switch provided.

NOTE: Ensure that when the on-board open button is depressed and the door moves in the correct open direction that activation of the open limit switch illuminates the "OPEN LIMIT" LED and stops the door.

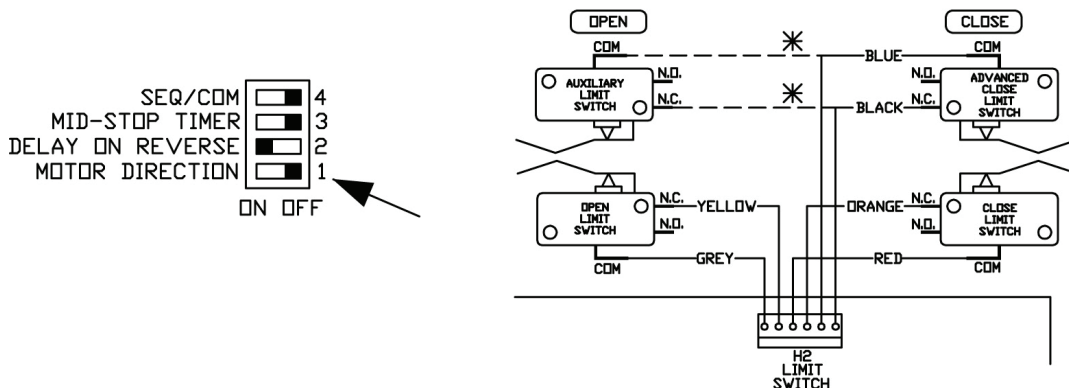

For 3-Phase Operators: If door moves in wrong direction, turn off incoming power and reverse any two of the three incoming power supply leads to correct rotation. Press the on board open button again. If door is going in the correct open direction, activate the open limit switch to ensure door stops. If door does not stop, turn off incoming power and interchange any two incoming power lines once again and slide dipswitch #1 to reverse motor direction. If motor direction is reversed, the open and close limit switches are automatically reversed. However, the advanced close limit switch needs to be manually changed. To do this, disconnect the 2 wires from the advanced limit switch and re-connect to the auxiliary limit switch provided.

NOTE: Ensure that when the on-board open button is depressed and the door moves in the correct open direction that activation of the open limit switch illuminates the "OPEN LIMIT" LED and stops the door.

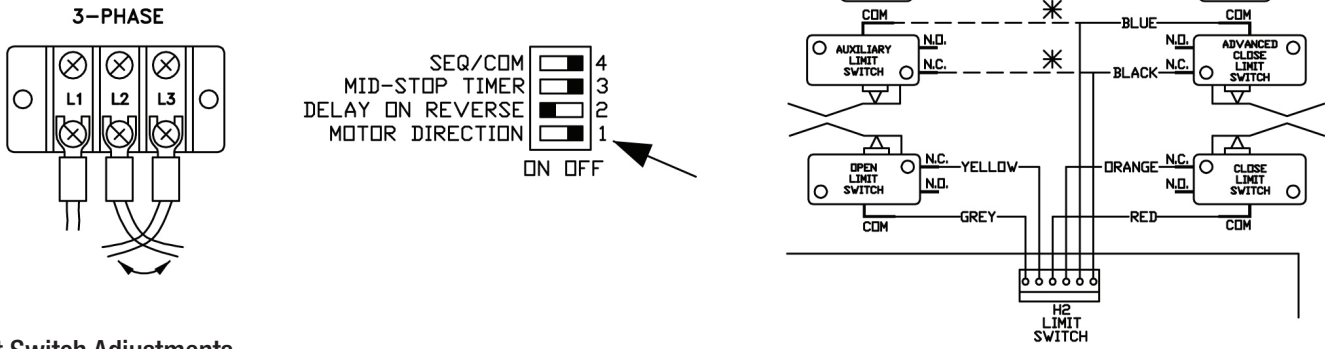

Limit Switch Adjustments

Once the motor rotation and limit cam direction have been verified, adjust the limit cam settings. Please note that when each limit switch is activated the corresponding LED will light up. Refer to operator installation manual for complete limit switch adjustment instructions.

Connection of External O/C/S PBS

Connect O/C/S PBS as shown in diagram.

NOTE: Jumper #1 must be removed after the external O/C/S PBS has been installed.

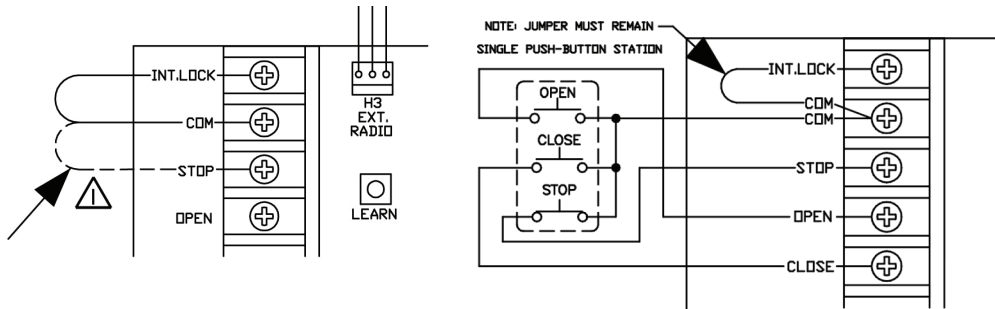

Failsafe Feature

A safety device failsafe feature is built into the logic board. The logic board has provisions to connect one primary monitored safety device as well as 1 or more secondary non-monitored safety device(s).

Primary monitored safety device

Nice monitored failsafe photo beams or Nice compatible monitored failsafe devices must be connected to terminals P1 and P2 as primary monitored safety device. Primary monitored safety device must be connected if momentary activation on close is required in B2, T and TS modes. If it is not connected in B2, T and Ts modes, door can only be closed by constant pressure on close and if constant pressure is removed before door reaches full close position, door reverses to full open.

NOTE: Only one monitored failsafe device can be connected to terminals P1 and P2.

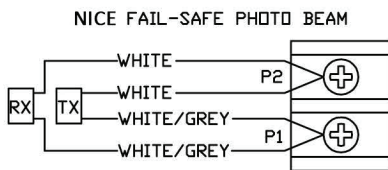

IMPORTANT!
NICE MONITORED SAFETY DEVICES MUST BE CONNECTED IF MOMENTARY ACTIVATION ON CLOSE IS REQUIRED.

Secondary Non-Monitored Safety Device(s):

A standard 2-wire safety edge, non-monitored photo beams or any other non-monitored reversing devices with a N.O contact can be connected to terminals S1 and S2 as secondary non-monitored safety device.

NOTE: More than one secondary non-monitored safety device can be connected to terminals S1 and S2.

IMPORTANT: Do not remove the resistor that is factory installed across terminals S1 and S2 unless installing a 4-wire electric edge.

4-wire electric edge:

A standard 4-wire electric edge can be connected across S1 and S2 terminals as a secondary safety device.

Remove the factory-installed resistor across terminals S1 and S2 when using a 4-wire electric edge.



Connection of External Single-Button Device

Connect an external single-button as shown in diagram. Please refer to “Modes of Operation” for the functionality of single-button.

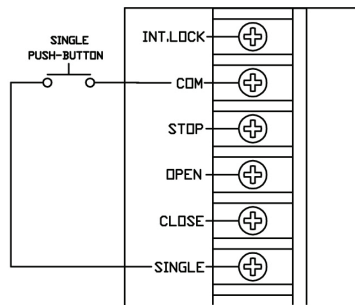

Modes of Operation

All operators leave the factory in the D1 mode setting; please read all modes of operation and determine which operational mode is desired.

B2 (Momentary on open and close):

- **Open Button:** Momentary activation opens the door. When door is closing, momentary activation reverses the door (OPEN OVERRIDE). Momentary contact from mid-stop opens the door to full open position. Constant activation when door is opening, bypass mid-stop if enabled.
- **Close Button:** Momentary on close.
- **Stop Button:** Momentary activation stops the door.
- **Single Button Device and Single Channel Transmitter, 3-Channel (1,2,3) Transmitter:**
 - » **SEQUENTIAL FUNCTION:** Open/Stop/Close/Reverse.
 - » **COMMERCIAL FUNCTION:** Open/Close/Reverse.
- **3-Button O/C/S Radio Transmitter:** Same as open, close and stop buttons.
- **Safety Devices:** When door is closing, momentary activation reverses the door.
- **Timer to Close:** N/A

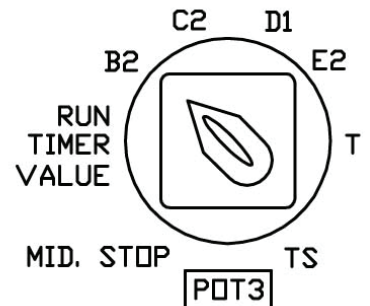

C2 (Momentary open, constant pressure close):

- **Open Button:** Momentary activation opens the door. When door is closing, momentary activation reverses the door (OPEN OVERRIDE). Momentary contact from mid-stop opens the door to full open position. Constant activation when door is opening, bypass mid-stop if enabled.
- **Close Button:** Constant pressure on close. Door will stop when button is released
- **Stop Button:** Momentary activation stops the door.
- **Single Button device:**
 - » **SEQUENTIAL FUNCTION:** Open/Stop/Constant pressure on close/stop.
 - » **COMMERCIAL FUNCTION:** Open/Constant pressure on close/stop.
- **Single channel transmitter, 3-channel (1,2,3) transmitter and 3-button O/C/S radio transmitter.** Momentary activation opens the door. Momentary contact of OPEN button on 3-button (O/C/S) radio transmitter from mid-stop opens the door to full open position. Cannot close the door.
- **Safety Devices:** When door is closing, momentary activation reverses the door.
- **Timer to Close:** N/A

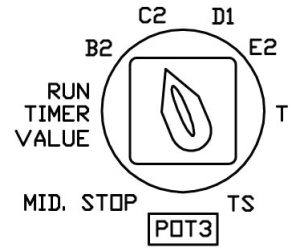

D1 (Constant pressure on open and close):

- **Open Button:** Constant pressure opens the door. Door stops when constant pressure is released. Constant pressure from mid-stop opens the door to full open position.
- **Close Button:** Constant pressure on close. Door will stop when button is released
- **Single Button device, single channel transmitter, 3-channel (1,2,3) transmitter and 3-button (O/C/S) radio transmitter:** N/A
- **Safety Devices:** When door is closing, momentary activation reverses the door.
- **Timer to Close:** N/A

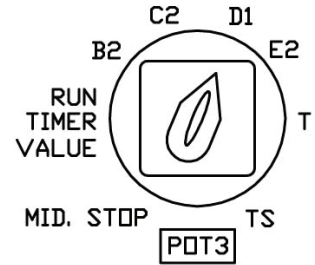

E2: (Momentary on open, constant pressure on close with roll-back feature)

- **Open Button:** Momentary activation opens the door. When door is closing, momentary activation reverses the door. Momentary contact from mid-stop opens the door to full open position. Constant activation when door is opening, bypass mid-stop if enabled.
- **Close Button:** Constant pressure on close. Door reverses to full open when button is released.
- **Single Button:**
 - » **SEQUENTIAL FUNCTION:** Open/Stop/Constant pressure on close/stop.
 - » **COMMERCIAL FUNCTION:** Open/Constant pressure on close/reverse.
- **Single channel device, 3-channel (1,2,3) transmitter and 3-button (O/C/S) radio transmitter:** Momentary activation opens the door. Momentary contact of OPEN button on 3-button (open/close/stop) radio transmitter from mid-stop opens the door to full open position. Cannot close the door.
- **Safety Devices:** When door is closing, momentary activation reverses the door.
- **Timer to Close:** N/A

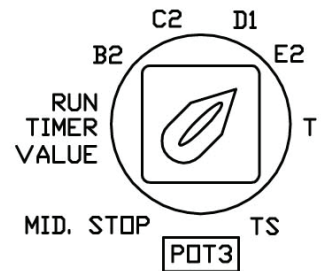

T: (Momentary on open and close, timer to close, SAFETY ACTIVATION & STOP BUTTON DISABLE TIMER)

- **Open Button:** Momentary activation opens the door. When door is closing, momentary activation reverses the door. Momentary contact from mid-stop opens the door to full open position. Momentary contact at full-open refreshes the timer if enabled at full open. Momentary contact at full open position re-activates the timer if timer is disabled previously by stop button or safety device. Constant activation when door is opening, bypass mid-stop if enabled.
- **Close Button:** Momentary on close.
- **Single Button:** If door is opening or closing, momentary activation stops the door. Momentary activation while timer is counting at mid-stop or full open deactivates the timer.
- **Single button device, single channel and 3-channel (1,2,3) radio transmitter:**
 - » **SEQUENTIAL FUNCTION:** Open/Stop/Close/Reverse.
 - » **COMMERCIAL FUNCTION:** Open/Reverse/Refresh timer.
- **3-button (O/C/S) Transmitter:** Same as open, close, stop buttons.
- **Safety Devices:** When door is closing, momentary activation reverses the door to full open AND DISABLES TIMER.

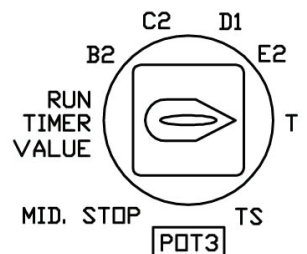

- **Timer to Close:** Closes the door from mid-stop or full open. Momentary activation of stop button will deactivate the timer. When door is closing, momentary activation of safety devices will reverse the door to mid-stop (if enabled) or full open and deactivates the timer. Timer resumes its normal operation upon momentary activation of open push button or once the close cycle is completed. If mid-stop is enabled and “Timer from mid-stop only” dip-switch is ON, timer is enabled only from mid-stop and disabled from full open. If mid-stop is enabled and “Timer from mid-stop only” dip-switch is OFF, timer is enabled from full open and mid-stop.

TS: (Momentary on open and close, timer to close secure, STOP BUTTON DISABLES TIMER)

- **Open Button:** Momentary activation opens the door. When door is closing, momentary activation reverses the door. Momentary contact from mid-stop opens the door to full open position. Momentary contact at full-open refreshes the timer if enabled at full open. Momentary contact at full open position re-activates the timer if timer has been disabled previously by stop button. Constant activation when door is opening, bypass mid-stop if enabled.
- **Close Button:** Momentary on close.
- **Stop Button:** If door is opening or closing, momentary activation stops the door. Momentary activation while timer is counting at mid-stop or full open deactivates the timer.
- **Single button device, single channel transmitter and 3-channel (1,2,3) radio transmitter:**
 - » **SEQUENTIAL FUNCTION:** Open/Stop/Close/Reverse.
 - » **COMMERCIAL FUNCTION:** Open/Reverse/Refresh timer.
- **3-button O/C/S radio transmitter:** Same as open, close, stop buttons.
- **Safety Devices:** When door is closing, momentary activation reverses the door. Momentary activation refreshes the timer to close.
- **Timer to Close:** Closes the door from mid-stop or full open. Momentary activation of stop button will deactivate the timer. Timer resumes its normal operation upon momentary activation of open push button or once the close cycle is completed. If mid-stop is enabled and “Timer from mid-stop only” dip-switch is ON, timer is enabled only from mid-stop and disabled from full open. If mid-stop is enabled and “Timer from mid-stop only” dip-switch is OFF, timer is enabled from full open and mid-stop.

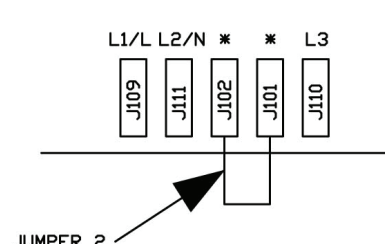
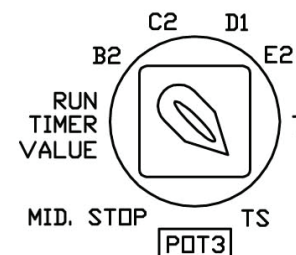

WARNING: When replacing the logic board in a single-phase operator. Make sure that Jumper 2 is installed properly before operating the door. Failure to do this will damage the logic board.

Programming Instructions

NOTE: ALL PROGRAM FUNCTIONS CAN BE INITIATED BY TURNING SELECTOR SWITCH TO THE DESIRED SETTING AT ANY POINT DURING OPERATION EXCEPT FOR THE MID STOP and RUN TIMER MODE. PROGRAMMING MUST START FROM THE FULL CLOSED POSITION.

Run-Timer Setup

Run-timer is the maximum amount of time the motor will run upon receiving an open or close command. The factory default value for run-timer is 45 seconds.

NOTE: Limits must be set prior to setting run timer.

Modify the run-timer from factory default:

1. Close the door to full close position.
2. Set the selector dial to “Run-timer” position. The “Delay On Close Timer”. LED should blink.
3. Press open button. Wait until door reaches full open position. The run timer value is set to the time taken for the door to travel from full close position to full open position plus 5 seconds.
4. Set the selector dial to the desired mode of operation.

Modify the run-timer to factory default:

1. Close the door to full close position.
2. Set the selector dial to “Run-timer” position.
3. Press **Stop Button**. The run-timer is modified to the factory default value. Then set the selector dial to the desired mode of operation.

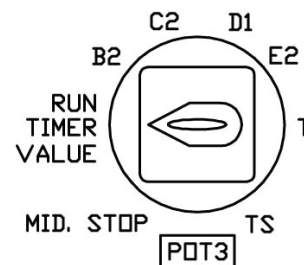

Mid-Stop Setup

Mid-Stop feature can be used to open the door to a preset point prior to full open position.

NOTE: Limits must be set prior to setting mid-stop position.

To Activate Mid-Stop:

1. Close the door to full close position.
2. Set the selector dial to “Mid-Stop” position. “Mid-Stop” LED starts blinking.
3. Press open push button. Door opens. Once the door reaches the desired mid-stop position, stop the door by activating stop push button.
4. Set the selector dial to the desired mode of operation.

NOTE: When door opens to the programmed mid-stop position, “Mid-Stop” LED will illuminate.

To Re-activate the Mid-Stop position:

1. Close the door to full close position.
2. Set the selector dial to “Mid-Stop” position.
3. Press the stop button, Mid-Stop is deactivated.

Modify mid-stop position:

To modify the current mid-stop position, follow the same steps to activate mid-stop. The new mid-stop position will override the old mid-stop position.

Modify mid-stop position:

To modify the current mid-stop position, follow the same steps to activate mid-stop. The new mid-stop position will override the old mid-stop position.

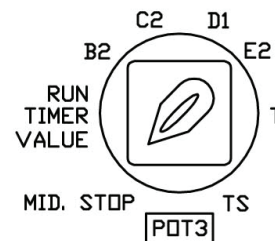

Timer to Close Setup

Timer to close is enabled only in TS and T modes of operation. To adjust the timer value turn POT1 clockwise to the desired value. The minimum value for timer to close is 3 seconds and the maximum value is 300 seconds.

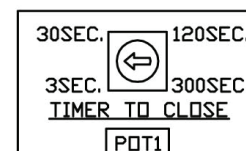

Delay on Close Setup (only for use with optional apartment board)

Delay on close timer can be used to delay the closing of the door in B2 and TS modes of operation. This timer is deactivated in C2, D1, E2 and T modes of operation. Delay on close timer is OFF when the “Delay on close” dial is set to OFF position. To adjust this timer, rotate the dial clockwise to the desired value. The minimum value for delay on close timer is 1 second and the maximum value is 60 seconds. It is recommended to use this feature in apartment applications where RED and GREEN traffic lights are used.

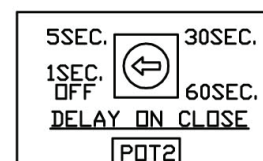

NOTE: In TS mode, the “Delay on close” timer starts only once the “Timer to close” has finished counting. Unless a delay on close is required this dial should be rotated to the OFF position. If left in any other position but OFF, activation of close button will delay to POT2 amount of time.

On-Board Receiver Programming

This logic board has a built-in 372 MHz radio receiver and can only be used with Nice single button, 3-button (OPEN/CLOSE/STOP) and 3-channel radio transmitters.

Installing the Antenna

Direct Connection:

Attach the antenna when supplied with the operator to the F connector on the control box. For best reception, keep antenna wire straight and away from metal objects.

Indirect connection (Mounting the antenna at a remote location):

1. Connect coax extension cable “optional” to the F connector on the control box.
2. Route cable inside metal enclosure.
3. Route and secure cable away from moving parts.

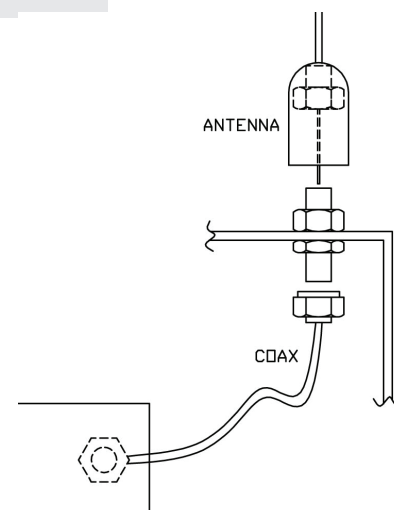

4. Mount antenna holder (not provided) outside enclosure.
5. Attach antenna to extension wire.
6. Position antenna wire straight. For best reception, keep antenna away from metal.

NOTE: Do not route coax cable near any moving parts of the operator. If necessary, secure coax wire away from any moving parts.

Programming the On-Board Radio Receiver

WARNING: During programming, door operator will activate. Keep people and objects away from door.

1. Connect power to door operator.
2. Press and release the learn button once. The receiver's LED will turn on.
3. To program a single button transmitter, press the button on the transmitter. The receiver's LED will blink twice indicating a successful programming.
4. Press the button on the transmitter once more to confirm operation of the door operator.
5. To program a 3-channel (1,2,3) transmitter, press any of the 3 buttons on the transmitter. The receiver's LED will blink twice indicating a successful programming. Press the same button on the transmitter to confirm operation of the door operator. This button is now associated with that particular receiver. You can repeat the programming process for the other two buttons to control two other receivers.
6. To program a 3-button (O/C/S) transmitter, press OPEN button on the transmitter. The receiver's LED will blink twice indicating a successful programming. Press the OPEN button on the transmitter to confirm operation of the door operator. The OPEN, CLOSE and STOP buttons on the transmitter can be used to open, close or stop the operator respectively.
7. Test range of transmitter. Repositioning antenna may provide greater range.
8. Repeat transmitter-programming steps for additional transmitters.

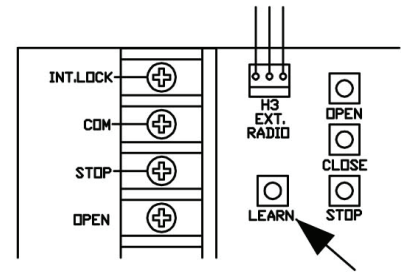

Operation

1. Press and release the button on Nice transmitter.
2. Receiver LED will light momentarily and door will cycle.

To Erase all Learned Transmitters

1. Press and hold down the LEARN button.
2. After 5 seconds, the LED will blink for 5 seconds.
3. Release the LEARN button during the time LED is blinking.
4. After you released the button, the LED will blink 5 times indicating all transmitters are erased from the receiver's memory.

NOTE: A maximum of 20 transmitters can be programmed for the same receiver. If more than 20 are required, consult factor.

Replacing Remote Control Batteries

The batteries (lithium, 3V) should produce power for up to 5 years. To replace the battery, open the transmitter by removing the screws on the back of the transmitter. Match the positive and negative terminals of the battery to the positive and negative terminals of the transmitter.

NOTE: The receiver and transmitter comply with part 15 of the FCC rules with RSS-210 of industry Canada. Operation is subject to the following two conditions: (1) this device may not cause harmful interference, and (2) this device must accept any interference received, including interference that may cause undesired operation.

NOTE: If an external radio-receiver (Nice or other) is used instead of the built-in radio receiver, it is highly recommended to disconnect the co-axial cable from the logic board.

NOTE: When using any external receiver, the Nice on-board receiver should not be used.

Dip-Switch Setup

| DIP-SWITCH | ON | OFF | NOTE |
|------------------|-------------------------------------|---|---|
| SEQ/COM | Single button and radio in SEQ mode | Single button and radio in COM mode | |
| Mid-stop Timer | Timer is enabled from mid-stop only | Timer is enabled from both mid-stop and full open | T or TS mode can be selected to enable a timer for mid-stop |
| Delay on reverse | Delay on revers is 1.5 seconds | Delay on revers is 0.5 seconds | Nice recommends 1.5 second delay on revers for all applications |
| Motor direction | Reverse motor direction | Standard motor direction | See NOTE ** below |

NOTE: If motor direction is reversed, the open and close limit switches are automatically reversed. However, the advanced close limit switch needs to be manually changed. To do this, disconnect the 2 wires from the advanced closed limit switch and re-connect to the auxiliary limit switch provided.

| LED | Status | Cause |
|----------------------|-----------|---|
| Fault | ON | <ul style="list-style-type: none"> » Primary safety devices not connected to P1 & P2 or not functioning properly » Safety devices are activated » 10k Ohm resistor (between S1 & S2) removed or faulty |
| Fault | Blinking | <ul style="list-style-type: none"> » Interlock is activated. » Interlock jumper is not connected |
| Run-out-timer | ON | Run-out timer has elapsed |
| Delay on close timer | Blinking | <ul style="list-style-type: none"> » Delay on close timer is counting » Selector dial is set to Run-timer |
| Timer to close | Blinking | Timer to close is counting. |
| Safety/Photo | ON | <ul style="list-style-type: none"> » Primary safety devices not connected to P1 & P2 or not functioning properly » Safety devices are activated » 10k Ohm resistor (between S1 & S2) removed or faulty |
| Mid. Stop | ON | Door is at Mid-stop position. |
| Close Limit | ON | Close limit switch is activated. |
| Open Limit | ON | Open limit switch is switched |
| Stop PB | ON OFF | <ul style="list-style-type: none"> » Stop button connected and functioning » Stop push button is activated (or the stop circuit is open). |
| Close Relay | Blinking | <ul style="list-style-type: none"> » Door is closing » Close relay is activated |
| Open Relay | Blinking | <ul style="list-style-type: none"> » Door is opening. » Open relay is activated. |
| Power | ON | 24 VAC power to logic board is ON. |

| | |
|----------------------|--|
| FAULT | |
| RUN-OUT TIMER | |
| DELAY ON CLOSE TIMER | |
| TIMER TO CLOSE | |
| SAFETY/PHOTO | |
| MID. STOP | |
| CLOSE LIMIT | |
| OPEN LIMIT | |
| STOP P.B. | |
| CLOSE RELAY | |
| OPEN RELAY | |
| POWER | |

SECTION D: For all Operator Control Types

Limit Switch Adjustment

Adjustment of door travel is done by moving the limit cams on the threaded shaft. The position of the 4 limit switches are factory adjusted and should not be altered. The limit switches are:

- “Open” limit switch: End of door travel in the fully open position
- “Closed” limit switch: End of door travel in the fully closed position
- “Advanced Open” or “Auxiliary advanced closed” limit switch:
 - A) For relay logic operators this advanced open limit switch is used for open/close devices or timer to close features.
 - B) For logic board this auxiliary closed limit switch is used for open/close devices used when motor direction is reverse of standard.
- “Advanced Closed” Limit switch: Used to prevent reversing device from reversing door when door is almost fully closed.

⚠ WARNING ⚠

TO REDUCE THE RISK OF INJURY OR DEATH: DO NOT ATTEMPT TO MAKE LIMIT SWITCH ADJUSTMENTS UNLESS POWER HAS BEEN ELECTRICALLY DISCONNECTED.

To adjust door travel:

1. **Open cycle:** Depress cam plate and spin “Open” limit cam away from “Open” limit switch to increase door travel or spin “Open” limit cam towards the “Open” limit switch to decrease door travel. After each adjustment ensure that cam plate fully engages in slots of both limit nuts.
2. Adjust “Open” limit cam so that door stops at the desired fully open position.
3. **Close cycle:** Depress cam plate and spin “Close” limit cam away from “Close” limit switch to increase door travel or spin “Close” limit cam towards the “Close” limit switch to decrease door travel. After each adjustment ensure that cam plate fully engages in slots of both limit nuts.
4. Adjust “Close” limit cam so that door stops at the desired fully closed position.

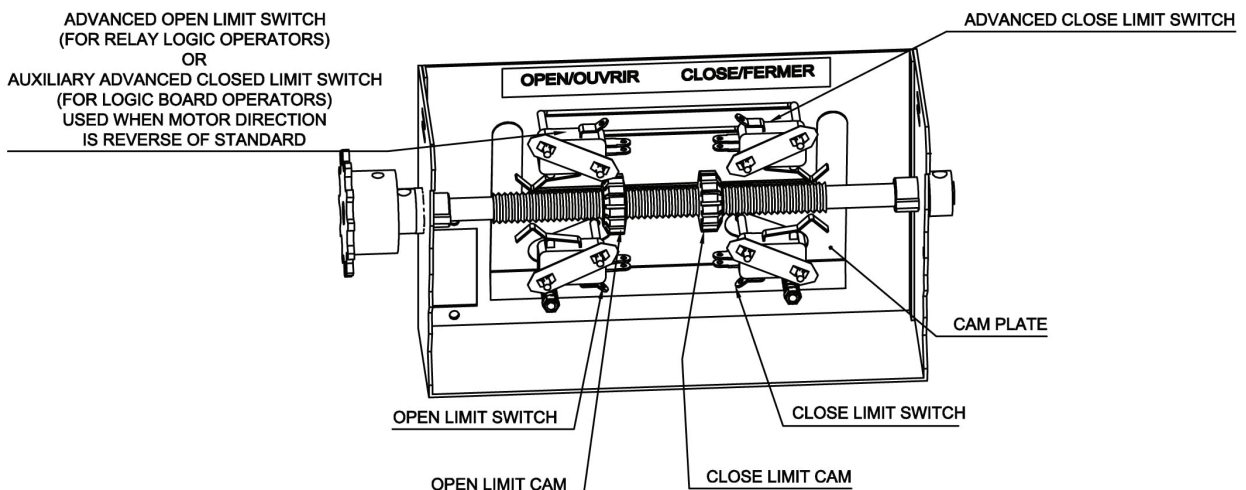

SECTION E: For Operators with Interface Modules or Logic boards

Installation of Nice N-1 or N-4 Photocells

Installation Safety Precautions

⚠ WARNING ⚠

Nice MK00649 NEMA-1 and FRABA MK00697 NEMA 4/4X infrared photo systems are for use only with Nice logic board operators or relay logic operators equipped with the Nice failsafe interface module. Use of this device on other than recommended operators can lead to severe or fatal injury. Follow these instructions carefully.

IMPORTANT

For momentary activation on close, the Nice photobeams (or a Nice 2-wire monitored edge), must be installed as part of the operator system. If a Nice 2-wire monitored edge or the Nice infrared photobeam system is not installed (or not operating correctly), the operator will only operate in fault mode "constant pressure to close".

READ and FOLLOW all installation instructions.

1. Before installing the photo beam, read the door or gate operator's instruction manual fully, so you are aware of all of the unit's functions and features.
2. Wear protective gloves and eye protection when using tools.
3. Before installing photo beam, disconnect all power to door operator to prevent unintended operation and have the door full open or close.
4. Do not reconnect power to the door or gate operator until instructed to do so.
5. Only install photobeams on a properly functioning door or gate operator.
6. Installation and wiring must comply with local building and electrical codes. This device is not intended and must not be installed in an explosive environment.

⚠ WARNING ⚠

Keep fingers and other body parts away from all moving parts of the door and gate operator system while the system is being operated.

⚠ WARNING ⚠

To prevent unintended operation, disconnect power to the door or gate operator prior to installing the photobeam system.

NICE N-1 Photocell (MK00649)

NOTE: The MK00649 photocell system has a maximum range of 24 ft. Sun visor protector optional.

Installation

NOTE: Photo beams should be mounted as close to the door track inside the door to offer maximum entrapment protection.

Wall installations

1. Select a location on the wall no more than 6 inches from the floor to install wall mounting brackets on the left and right side of the door. Both brackets must be mounted at the same height for proper alignment.
2. Drill holes in the wall and attach brackets to the wall using screws and nails provided as shown in Fig. 1.

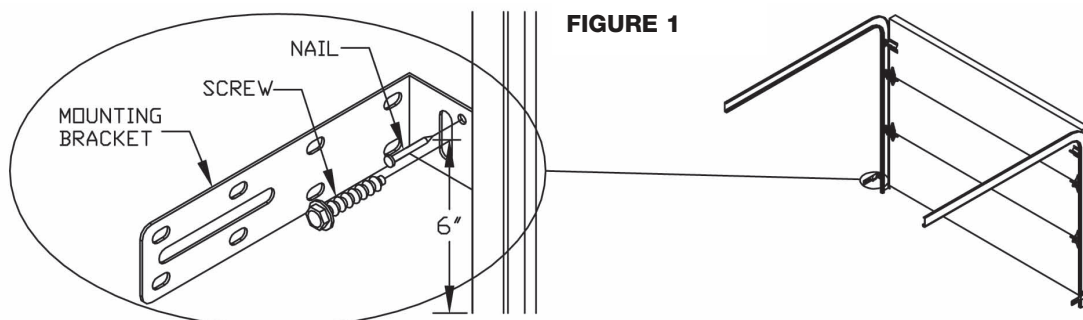

- Using the wing nuts, attach the receiver and transmitter of the photo system to the mounting brackets (with arrow pointing up). Note that the receiver and transmitter can be installed on the left side or right side of the door.
- Adjust the position of the transmitter and receiver on the slot of the brackets. Secure the receiver and transmitter to the mounting brackets as shown in figure 2.

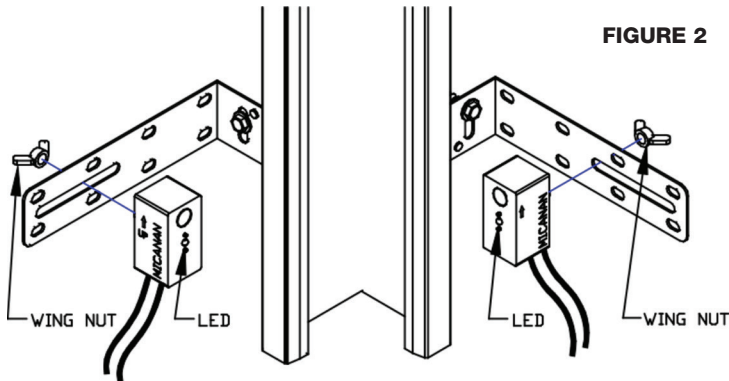
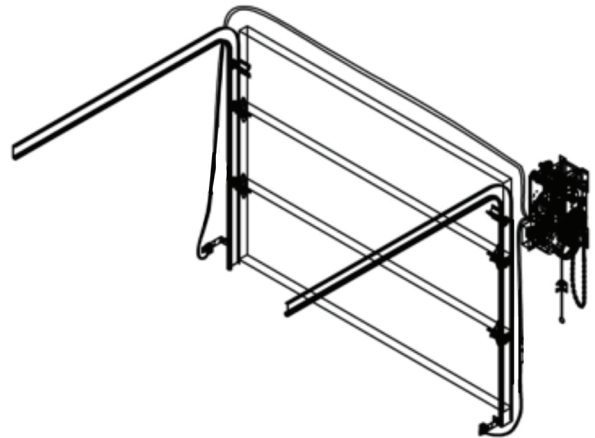

FIGURE 2



- Pair the two white wires and the two white/grey wires together from transmitter and receiver.
- Connect these paired wires to the P1 and P2 terminals on the logic board (or interface module if applicable) as shown in Figure 3.

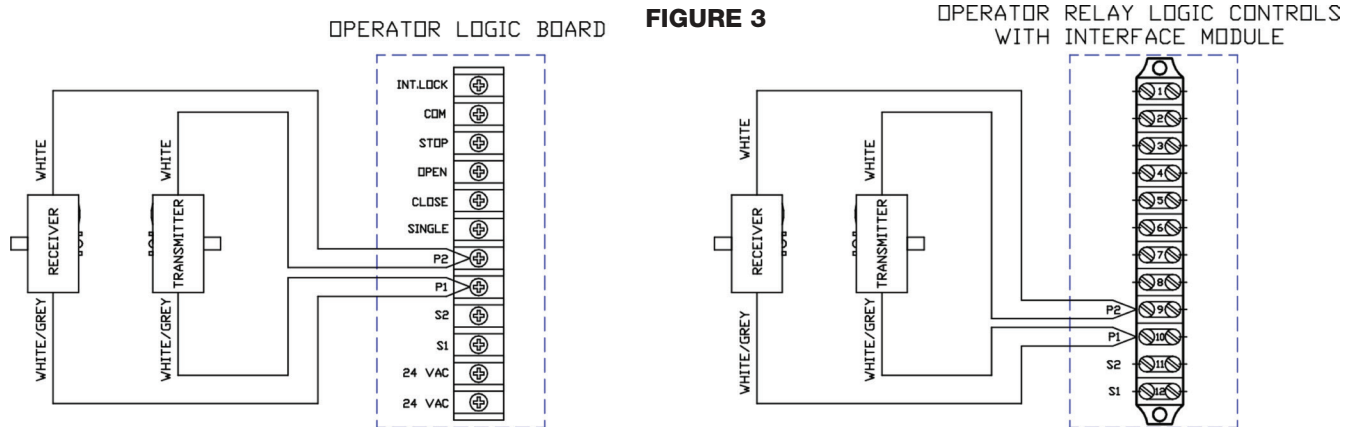

FIGURE 3

NICE N-4 Photocell (MK00650)

NOTE: The MK00650 photocell system has a maximum range of 24 ft. Sun Visor protector optional.

Installation

NOTE: Photo beams should be mounted as close to the door track inside the door to offer maximum entrapment protection.

Wall installation

- Select a location on the wall no more than 6 inches from the floor to install wall mounting brackets on the left and right side of the door. Both brackets must be mounted at the same height for proper alignment.
- Drill holes in the wall and attach brackets to the wall using screws and nails provided as shown in Fig. 1, page 24.

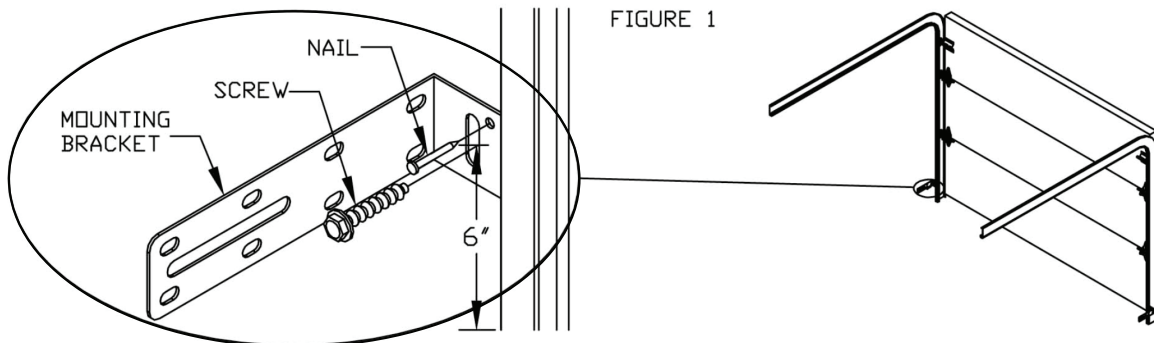
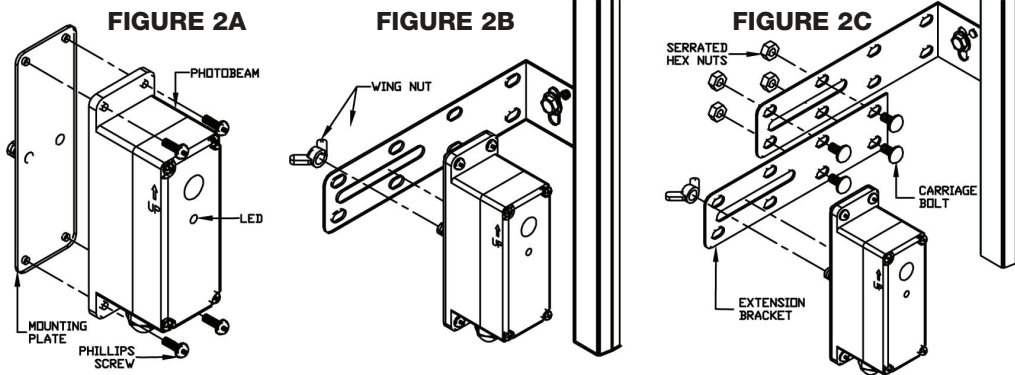
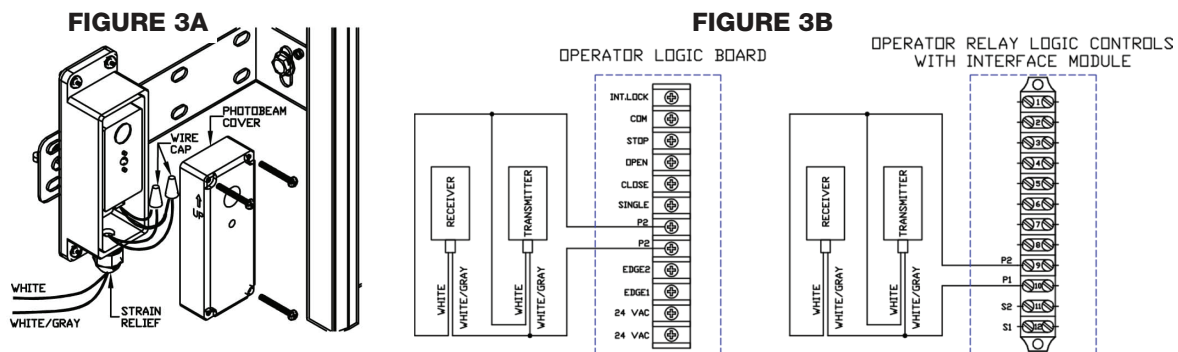

FIGURE 1

- Using the 8 Phillips head screws, attach the receiver and the transmitter to the two mounting plates (Fig. 2A).
- Using the wing nuts, attach the receiver and the transmitter of the photo system to the mounting L-brackets (with arrow pointing up) as shown in Fig. 2B. Note that the receiver and transmitter can be installed on the left or right side of the door. For applications requiring the photobeams to be further away from the wall, use the extension brackets provided as shown in Fig. 2C.



- Adjust the position of the transmitter and receiver on the slot of the brackets and tightly secure the wing nuts
- Loosen the 4 fastening screws and remove the cover from the photobeam transmitter and receiver housings and insert electrical wire through the strain relief (Fig. 3A). Pair the two white/gray wires together from transmitter and receiver.
- Connect these paired wires to the P1 and P2 terminals on the logic board (or interface module if applicable) as shown in Fig. 3B. Use minimum 18 gauge wires and secure the wires to wall or ceiling.



For Nice Nema-1 and Nema-4 photobeams:

Aligning the photo beams:

- Turn the power on to the operator. If the transmitter and receiver are installed properly, the lights on both the transmitter (red LED) and receiver (green LED) will be ON.
- If the photo beams are not aligned properly, the receiver light (green) is OFF. Adjust the position of the transmitter and/or the receiver on the slot of the mounting bracket until the light on the receiver is ON and then secure to the bracket.

Photo system operation:

Nice photo beams must be connected for the door to close in momentary mode (unless a Nice monitored 2-wire edge is connected). When the photo system is properly installed and aligned, the infrared beam will detect any obstruction in the path of the beam. Upon detecting an obstruction, closing door will stop and reverse to full open.

The Nice operator control circuit continuously monitors the correct operation of the photo system. If the photo beams are not connected or not functioning properly, the operator will go into fail-safe mode and closing door will reverse to full open. In fail-safe mode door can only be closed by constant pressure on close.

To test the photo system:

- Open the door to full open position.
- Close the door.
- When door is closing, obstruct the beam. The door should stop and reverse.

FRABA N-4/4 Thru-Beam Photocell (MK00697)

NOTE: The MK00687 photocell system has a maximum range of 45 ft. Sun Visor protector optional.

1. Select a location on the wall no more than 6 inches from the floor to install wall mounting brackets on the left and right side of the door. Both brackets must be mounted at the same height for proper alignment.
2. Drill holes in the wall and attach brackets to the wall using screws provided as shown in Fig. 1.

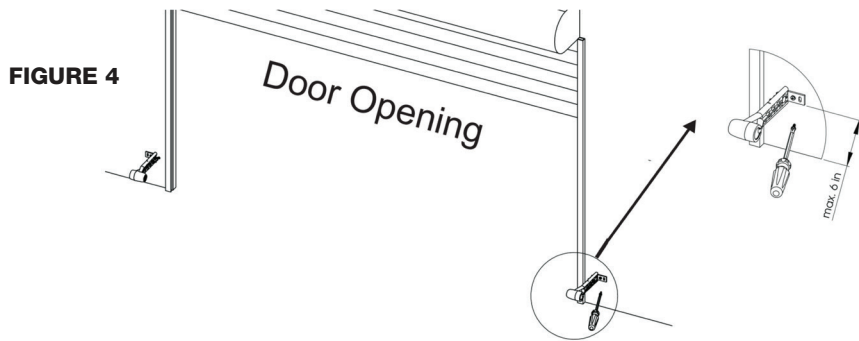

3. Plug sensors into flexible adapters as shown in Fig. 4. Please note that the 2 brackets are not identical. The receiver (Rx) must be installed into the receiver adapter and the transmitter (Tx) must be installed into the transmitter adapter (Fig. 5).

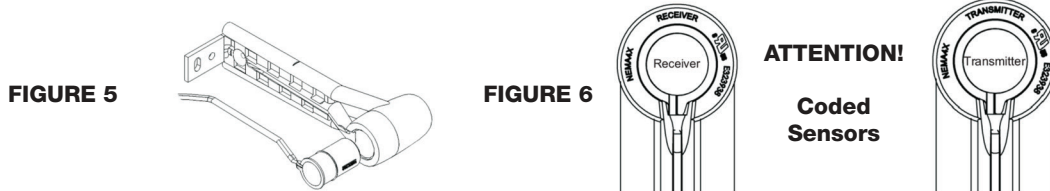

4. Pair the two black and the two black with white tracer wires together from transmitter and receiver. Connect these paired wires to the P1 and P2 terminals on the logic board (or interface module if applicable) as shown in Fig. 7. Use minimum 18 gauge wires and secure the wires to wall or ceiling.

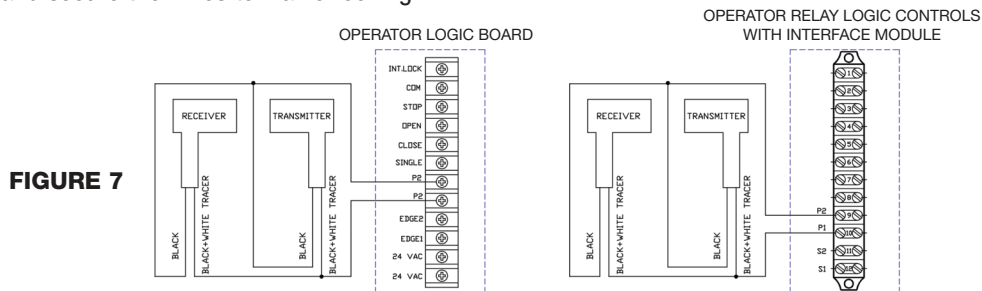

5. Turn the power on to the operator. Align transmitter and receiver by adjusting angle and height of the fixture (Fig. 8A and 8B).

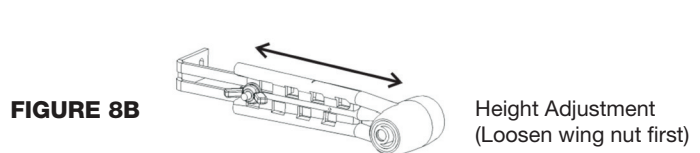
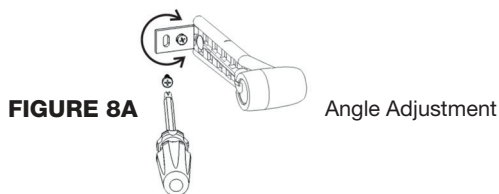

6. Utilize LEDs on photocells for alignment and trouble shooting. Make sure to tighten screws and wing nuts after photocells are aligned.
 - Red LED (ON), Green LED (ON): Normal operation
 - Red LED (ON), Green LED (OFF): No power. Verify wiring
 - Red LED (Blinking twice), Green LED (ON): Bad Alignment, or Obstructed Beam, or Rx defective
 - Red LED (Blinking twice), Green LED (OFF): Check power and wiring to Rx, or Rx defective
 - Red LED (Blinking three times), Green LED (ON): Rx receiving sunlight (or interference). Install visor or interchange position of transmitter and receiver to reduce sunlight affecting receiver.

To test the photo system: Open the door to full open position. Close the door. When door is closing, obstruct the beam. The door should stop and reverse.

Clutch Adjustment

Installation Safety Precautions

1. Remove cotter pin tapped to pulley.
2. Rotate clutch nut counterclockwise (loosen) until there is insufficient tension to permit clutch to drive door.
3. Gradually tighten clutch nut until the tension on the Spring is sufficient to permit clutch to drive door smoothly but will allow clutch to slip if door is obstructed. It should be possible to stop moving door by hand if clutch is properly adjusted.
4. Lock clutch nut in place by inserting cotter pin into one of the two adjustment holes provided.

Caution: Do not over-tighten the clutch as this will cause damage and create adjustment problems.

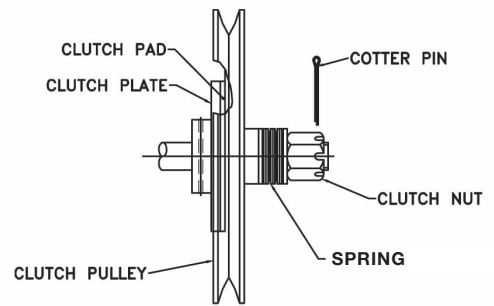

Brake Adjustment (For Pro-JB or HB Models)

If your operator was ordered with an optional solenoid brake system:

The brake adjustment is factory set and should only require minor adjustment after extensive use.

Verify brake adjustment by manually holding in solenoid plunger. When brake is properly adjusted, the brake shoe pads should make complete contact with brake drum with sufficient brake spring tension to stop and maintain door when solenoid is de-energized. When solenoid is energized, brake shoes should release from drum with sufficient clearance to avoid contact between shoes and drum.

To adjust brake tension, tighten (to increase) or loosen (to decrease) nylon lock nut on brake spring bolt. Observe solenoid during electrical testing of brake. Brake spring tension must be adjusted so that solenoid should pull and release smoothly and quietly. Too much or too little tension on brake spring may cause solenoid to burn out.

To adjust individual brake shoes, loosen nut on brake shoe adjustment bolt and adjust bolt. When properly adjusted, there should be a small clearance between adjustment bolt and solenoid bracket when solenoid is de-energized. When solenoid is energized, brake shoes should move away from drum with sufficient clearance to avoid friction between brake shoe pad and drum. After adjustments are made be sure to tighten nuts on brake shoe adjustment bolts.

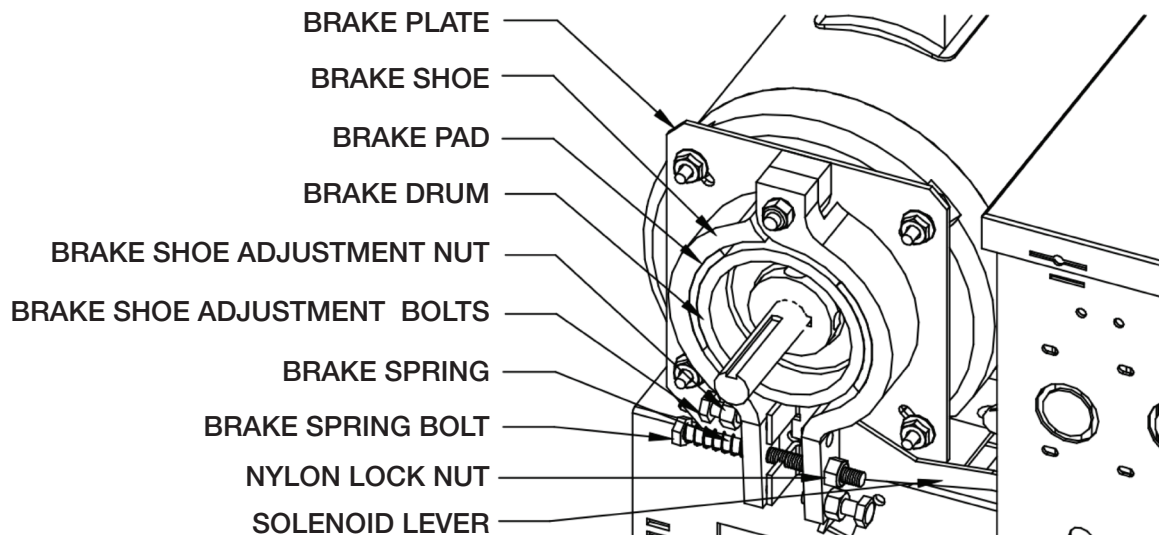

Emergency Manual Operation

- The PRO-J and PRO-H operators are equipped with an emergency disconnect device with interlocked power cut-out switch to manually operate door in case of emergency. This feature should not be used to manually operate a malfunctioning door.

⚠ WARNING ⚠

TO REDUCE THE RISK OF INJURY OR DEATH:

DO NOT ATTEMPT TO USE EMERGENCY DISCONNECT SYSTEM WHILE OPERATOR IS RUNNING.

POWER TO THE OPERATOR SHOULD BE TURNED OFF PRIOR TO OPERATING MANUALLY.

1. If operator is supplied with standard chain keeper: Pull the disconnect chain through the hole of keyhole and lock in place by inserting chain in slot of keyhole.

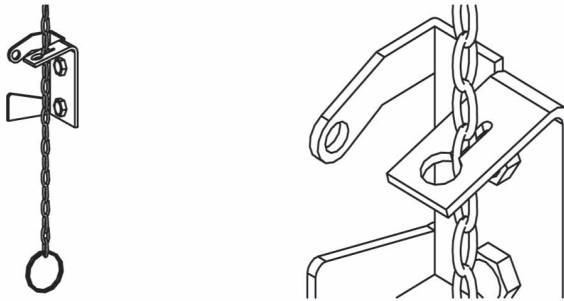

2. If operator is supplied with optional floor level disconnect lever: Pull disconnect lever downwards and lock in place by bending lever around bracket lip as shown.



For PRO-J operators: Move door manually. To return to electrical operation release disconnect chain and allow to return to original position.

For PRO-H operators: Operate door by pulling on hand chain. To return to electrical operation release disconnect chain and allow to return to original position. Lock hand chain in place (to Chain Keeper or Floor Level Disconnect) when not in use.

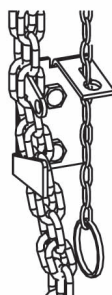

WARNING

TO REDUCE THE RISK OF INJURY OR DEATH:
DO NOT ATTEMPT TO SERVICE THE OPERATOR UNLESS
POWER SUPPLY HAS BEEN DISCONNECTED.

- Inspect manual function of the door every 3-months. Make sure that door runs smoothly. If door does not manually open or close freely, have a qualified service person make repairs. Do not attempt to electrically operate a malfunctioning door.
- Every 3 months:
 1. Verify that door area is kept clean. Remove any obstructions that would prevent proper door operation.
 2. Check for any excessive slack in chains. If chain adjustment is required verify and adjust limit switches, if necessary.
 3. Verify and adjust clutch and brake (Do not lubricate).
 4. Lubricate chains, bearings and limit shaft.
 5. Verify that motor, solenoid and operator runs smoothly and quietly.
- Every 6 months:
 1. Verify tightness of all fasteners and set screws.
 2. Verify that operator is properly secured.
 3. Inspect manual disconnect.
 4. Verify tension and condition of V-belt.
- Every 12 months:
 1. Perform a complete service check.
 2. Verify that inside of control box is clean and that grounding wires, terminations and power terminations do not show signs of corrosion.
 3. Verify tightness of all terminal strip screws and electrical connections.
 4. Verify power supply, voltage of input terminals during operation.
 5. Verify that current consumption of operator corresponds to nameplate information.

Jackshaft Operator Pro-J / Pro-JB Diagram

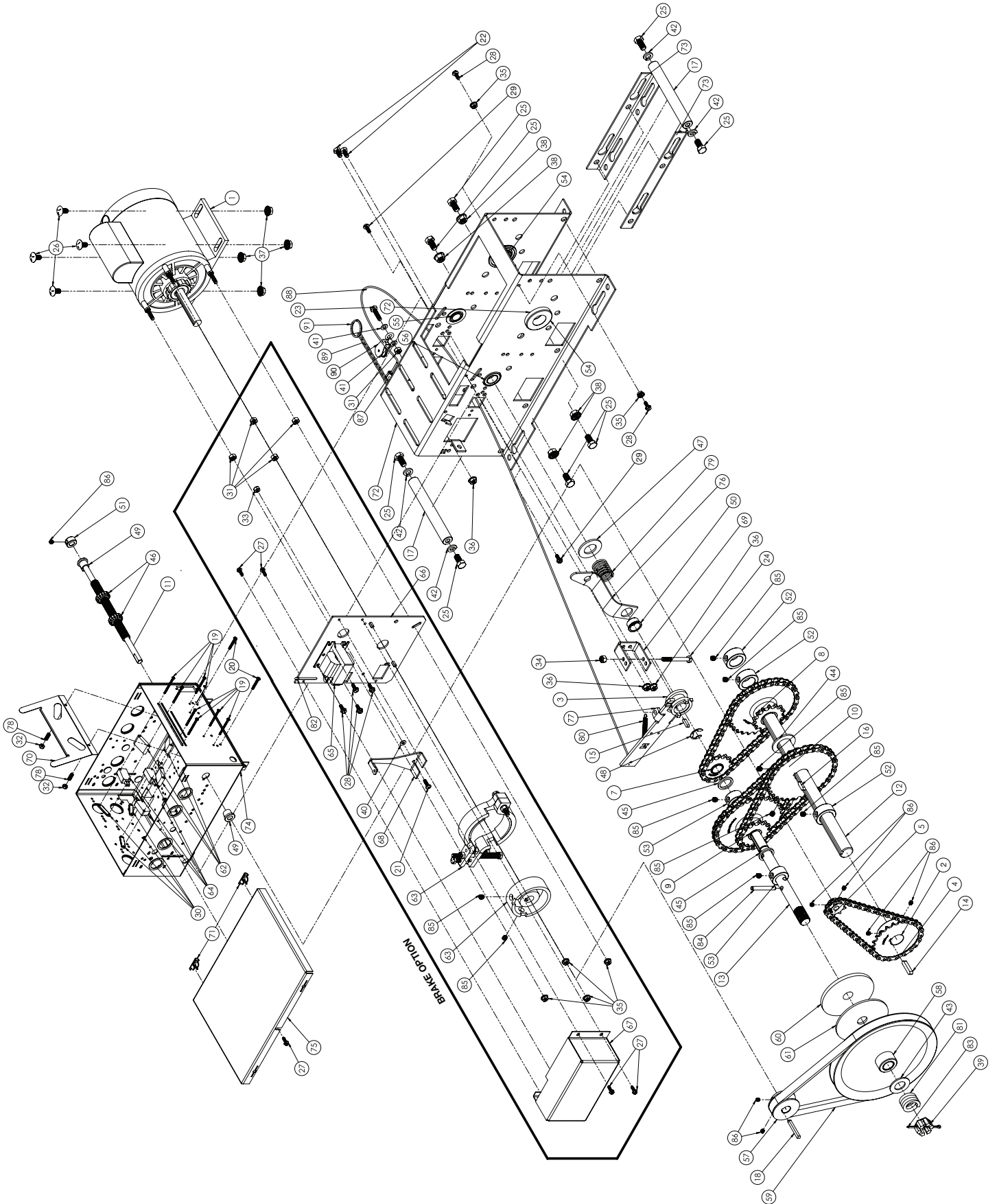

Jackshaft Operator Pro-J / Pro-JB Parts List

| CODE | ITEM # | DESCRIPTION (PRO-J/JB) | PRO-J | PRO-JB C/W BRAKE |
|---------|--------|---|----------|------------------|
| | | | QUANTITY | QUANTITY |
| MB01001 | 1 | Motor 1/2HP 110/220V 1Ph BM ODP | 1 | 1 |
| MB01102 | 1 | Motor 1/2HP 208/460V 3P BM ODP | 1 | 1 |
| MB01202 | 1 | Motor 1/2HP 575V 3Ph BM ODP | 1 | 1 |
| MB02001 | 1 | Motor 3/4HP 110/220V 1Ph BM ODP | 1 | 1 |
| MB01301 | 1 | 3 WIRE MOTOR 1/2HP 110V 1PH BM | 1 | 1 |
| MB01303 | 1 | 3 WIRE MOTOR 3/4HP 110V 1PH BM | 1 | 1 |
| MB03002 | 1 | MOTOR 1HP 110/220V 1PH BM TEFC | 1 | 1 |
| MB02102 | 1 | MOTOR 3/4HP 208/460V 3PH BM ODP | 1 | 1 |
| MB02202 | 1 | MOTOR 3/4HP 575V 3PH BM ODP | 1 | 1 |
| MB33201 | 1 | MARATHON MOTOR 1HP 208/460V 3PH BM ODP | 1 | 1 |
| MB03202 | 1 | MOTOR 1HP 575V 3PH BM ODP | 1 | 1 |
| MD00025 | 2 | Sprocket 410B23 x 1" | 1 | 1 |
| MD00027 | 3 | Disconnect Coupling 3/4 ID | 1 | 1 |
| MD00093 | 4 | #410 Chain (45 Links C/W Link) | 1 | 1 |
| MD00111 | 5 | Sprocket 410B9 x 3/8" | 1 | 1 |
| MD00243 | 6 | #41 Chain (47 Links C/W Link) | 3 | 3 |
| MD00244 | 7 | Sprocket 41B14 x 3/4" C/W Bushing & Slot | 1 | 1 |
| MD00246 | 8 | 41B32-41B14 x 1" Sprocket with Brass Bushing | 1 | 1 |
| MD00247 | 9 | 41B32-41B14 x 3/4" Sprocket with Brass Bushing | 1 | 1 |
| MD00280 | 10 | 41B32 Sprocket with 1" Bore x 0.25" KW 2SS | 1 | 1 |
| ME00001 | 11 | Limit Shaft 3/8" - 1/2" x 9.75" | 1 | 1 |
| ME00007 | 12 | Drive Shaft 1" x 15" | 1 | 1 |
| ME00010 | 13 | Pro-J Input Shaft 3/4" x 11-9/16" | 1 | 1 |
| ME00017 | 14 | Keyway 1/4" SQ x 1-1/4" Long | 1 | 1 |
| ME00019 | 15 | Keyway 3/16" x 3/16" x 3/4" Rounded Ends | 1 | 1 |
| ME00048 | 16 | Keyway 1/4" SQ x 3/4" Long | 1 | 1 |
| ME00050 | 17 | Frame Support Shaft 3/4" x 6" | 2 | 2 |
| ME00055 | 18 | Square Keyway 3/16" x 1-3/4" Long | 1 | 1 |
| MF00003 | 19 | R.H. Philips Machine Screw 4-40 UNC x 1-1/2" | 8 | 8 |
| MF00004 | 20 | R.H. Philips Machine Screw 6-32 UNC x 1" | 2 | 2 |
| MF00005 | 21 | R.H. Philips Machine Screw 10-32UNF x 5/8" | 1 | 2 |
| MF00006 | 22 | Hex Head Bolt 1/4"-20UNC x 1/2" | 2 | 1 |
| MF00008 | 23 | Hex Head Bolt 1/4"-20UNC x 1" | 1 | 1 |
| MF00009 | 24 | Hex Head Bolt 1/4" - 20UNC x 2-1/4" (Partial Thread) | 1 | 8 |
| MF00011 | 25 | Hex Head Bolt 3/8"-16UNC x 3/4" Long | 8 | 4 |
| MF00012 | 26 | Carriage Bolt 5/16-18UNC x 5/8" | 4 | 1 |
| MF00045 | 27 | "Hex Head Slotted Self Rounding Washer Head Screw 8-32UNF x 3/8" | 5 | 2 |
| MF00046 | 28 | "Hex Head Slotted Self Rounding Washer Head Screw 10-32UNF x 1/2" | 6 | 2 |
| MF00124 | 29 | HHB Ser Wash Type F Head Reg Thr #10-32 x 1/2" | 2 | 4 |
| MG00003 | 30 | Double Nut for Lim-Sw | 4 | 1 |
| MG00006 | 31 | Hex Nut 1/4-20UNC | 5 | 2 |
| MG00007 | 32 | Hex Nylon Lock Nut 6-32UNC | 2 | 1 |
| MG00008 | 33 | Hex Nylon Lock Nut 10-32UNF | 1 | 2 |
| MG00009 | 34 | Hex Nylon Lock Nut 1/4"-20UNC | 1 | 3 |
| MG00010 | 35 | Ribbed Hex Nut 10-32UNF | 6 | 4 |
| MG00011 | 36 | Ribbed Hex Nut 1/4"-20 | 3 | 4 |
| MG00012 | 37 | Ribbed Hex Nut 5/16-18UNC | 4 | 1 |
| MG00013 | 38 | Ribbed Hex Nut 3/8" -16 UNC | 4 | 2 |
| MG00014 | 39 | Slotted Hex Nut 3/4-24UNF | 1 | 1 |
| MG00016 | 40 | Flat Washer #10 | 1 | 1* |

| | | | | |
|---------|----|---|---|----|
| MG00017 | 41 | Flat Washer 0.25 ID x 0.5" OD | 2 | 1* |
| MG00018 | 42 | Lock Washer for 3/8" Screw | 4 | 4 |
| MG00019 | 43 | Flat Washer 13/16" ID x 1.5" OD | 1 | 1 |
| MG00020 | 44 | Flat Washer 1-1/16" ID x 1-3/4" OD | 1 | 1 |
| MG00021 | 45 | Flat Washer 7/8" ID x 1-1/8" OD | 2 | 2 |
| MG00030 | 46 | Limit Cam 1/2"-20UNF | 2 | 2 |
| MG00121 | 47 | Flat Washer 15/16" ID x 1-3/4" OD x 1/8" T | 1 | 1 |
| MG00122 | 48 | C-Clip 5/8" For 3/4" Shaft | 1 | 1 |
| MH00001 | 49 | T-Bushing 3/8" ID | 2 | 2 |
| MH00003 | 50 | Bronze Flange Bushing 3/4" ID x 7/8" OD | 1 | 1 |
| MH00006 | 51 | Collar 3/8" ID - 3/4" OD | 1 | 1 |
| MH00007 | 52 | Collar 1" ID - 1.5" OD | 3 | 3 |
| MH00008 | 53 | Collar 3/4" ID - 1.25" OD | 2 | 2 |
| MH00009 | 54 | Flanged Bearing 1" ID x 2" OD | 2 | 2 |
| MH00020 | 55 | Flange Bearing C10-22F 5/8" ID x 1-3/8" OD | 1 | 1 |
| MH00109 | 56 | Precision Flange Bearing 3/4" ID x 1-3/8" OD with Snap Ring | 1 | 1 |
| MI00001 | 57 | Motor Pulley 5L 5/8" ID x 2" OD | 1 | 1 |
| MI00002 | 58 | 5L Pulley 8" OD C/W Bushing 0.75" ID | 1 | 1 |
| MI00006 | 59 | V Belt 5L-325 | 1 | 1 |
| MJ00004 | 60 | Clutch Plate 0.75" ID | 1 | 1 |
| MJ00005 | 61 | Clutch Pad | 1 | 1 |
| MJ00006 | 62 | Limit Switch Double Spacer 3/4" | 4 | 4 |
| MJ00013 | 63 | Brake Assembly #1 (Standard Operator) | 1 | 4 |
| MK00004 | 64 | Limit Switch | 4 | 1 |
| MK00026 | 65 | Solenoid 120V | 1 | 1 |
| MK00027 | 65 | Solenoid 240V | 1 | 2 |
| MK00028 | 65 | Solenoid 460V | 1 | 1 |
| MK00029 | 65 | Solenoid 575V | 1 | 2 |
| MM00010 | 66 | HHD Brake Plate MSI0007 | 1 | 1 |
| MM00011 | 67 | Solenoid Cover | 1 | 1 |
| MM00014 | 68 | Solenoid Lever | 1 | 1 |
| MM00023 | 69 | Support U-Bracket Pro-J | 1 | 1 |
| MM00024 | 70 | Cam Plate | 1 | 2 |
| MM00046 | 71 | Control Box Hinge | 2 | 1 |
| MM00150 | 72 | Frame | 1 | 1 |
| MM00151 | 73 | Frame Foot HR | 2 | 1 |
| MM00152 | 74 | Control Box | 1 | 1 |
| MM00153 | 75 | Control Box Cover | 1 | 1 |
| MM00161 | 76 | Cut-Out Switch Lever JR | 1 | 7 |
| MM00162 | 77 | Disconnect Arm JR | 1 | 7 |
| MO00001 | 78 | Cam Plate Compression Spring (0.178ID x 0.032G x 0.55L) | 2 | 1 |
| MO00006 | 79 | Spring #5 0.92"ID x 0.09" x 2.00" LB E.G. #5 | 1 | 1 |
| MO00019 | 80 | Pro-J Extension Spring #12 | 1 | 1 |
| MO00027 | 81 | Clutch Spring 0.812 ID x 0.218 WD x 1" - 4 Coil | 1 | 1 |
| MQ00001 | 82 | Cotter Pin 1/8 x 1.5" | 1 | 1 |
| MQ00002 | 83 | Cotter Pin 1/8 x 2.5" | 1 | 4 |
| MQ00007 | 84 | Spring Pin 1/4" x 2" | 1 | 4 |
| MQ00008 | 85 | Set Screw 5/16"-18UNC | 9 | 4 |
| MQ00009 | 86 | Set Screw 1/4"-20 | 7 | 1 |
| MQ00011 | 87 | 3/32" Aluminum Oval Sleeves | 1 | 2 |
| MR00001 | 88 | Disconnect Cable 3/32" x 13" Long | 1 | 1 |
| MR00008 | 89 | Disconnect Sash Chain | 1 | 1 |
| MU00001 | 90 | Swivel Pulley | 1 | 1 |
| MU00002 | 91 | Keyring 1-1/4" | 1 | 1 |

Jackshaft Operator Pro-H / Pro-HB Diagram

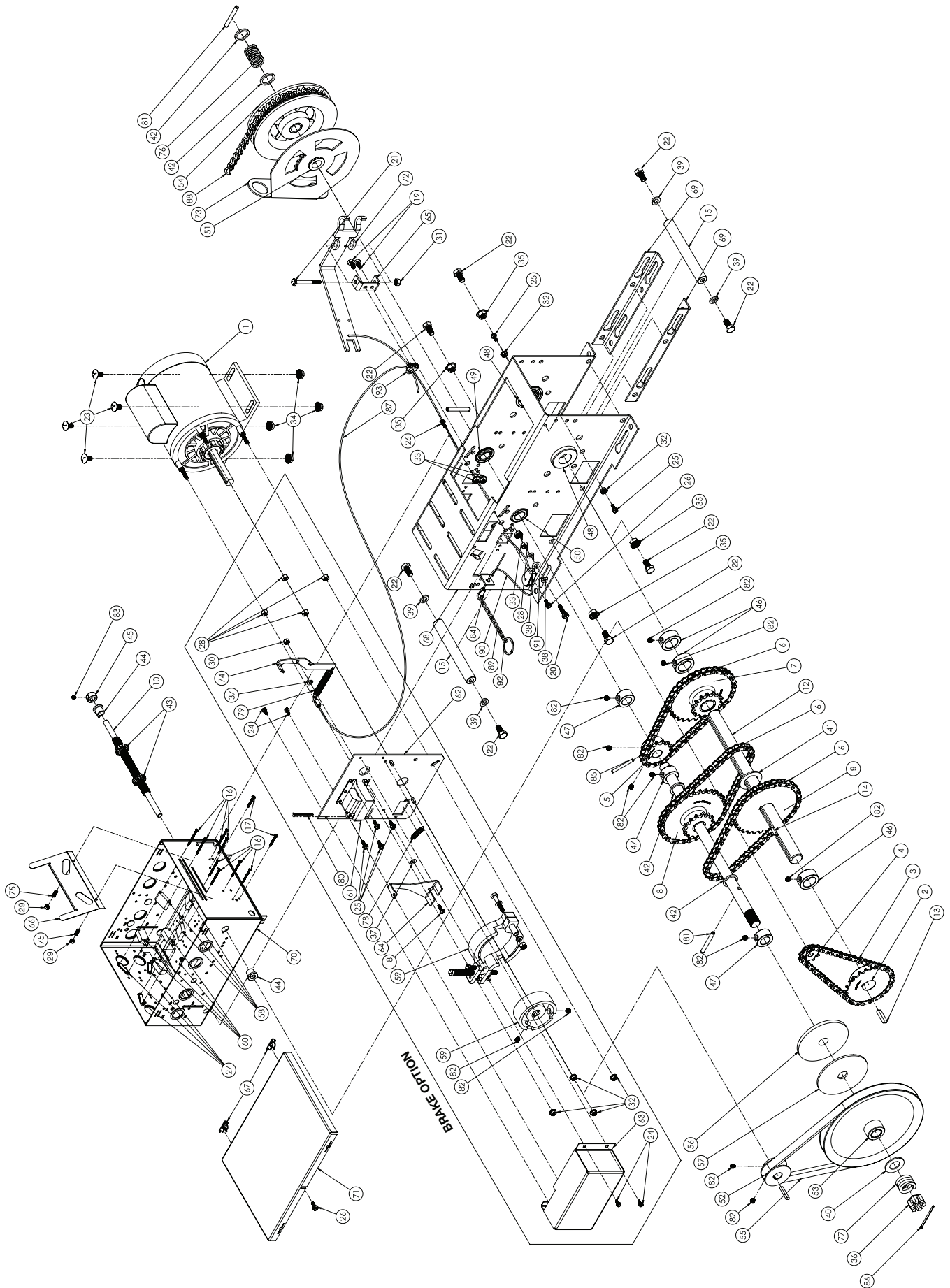

Jackshaft Operator Pro-H / Pro-HB Parts List

| CODE | ITEM # | DESCRIPTION (PRO-H/HB) | PRO-H | PRO-HB C/W BRAKE |
|---------|--------|--|----------|------------------|
| | | | QUANTITY | QUANTITY |
| MB01001 | 1 | Motor 1/2HP 110/220V 1Ph BM ODP | 1 | 1 |
| MB01102 | 1 | Motor 1/2HP 208/460V 3P BM ODP | 1 | 1 |
| MB01202 | 1 | Motor 1/2HP 575V 3Ph BM ODP | 1 | 1 |
| MB02001 | 1 | Motor 3/4HP 110/220V 1Ph BM ODP | 1 | 1 |
| MB01301 | 1 | 3 WIRE MOTOR 1/2HP 110V 1PH BM | 1 | 1 |
| MB01303 | 1 | 3 WIRE MOTOR 3/4HP 110V 1PH BM | 1 | 1 |
| MB03002 | 1 | MOTOR 1HP 110/220V 1PH BM TEFC | 1 | 1 |
| MB02102 | 1 | MOTOR 3/4HP 208/460V 3PH BM ODP | 1 | 1 |
| MB02202 | 1 | MOTOR 3/4HP 575V 3PH BM ODP | 1 | 1 |
| MB33201 | 1 | MARATHON MOTOR 1HP 208/460V 3PH BM ODP | 1 | 1 |
| MB03202 | 1 | MOTOR 1HP 575V 3PH BM ODP | 1 | 1 |
| MD00025 | 2 | Sprocket 410B23 x 1" | 1 | 1 |
| MD00093 | 3 | #410 Chain (45 Links C/W Link) | 1 | 1 |
| MD00111 | 4 | Sprocket 410B9 x 3/8" | 1 | 1 |
| MD00242 | 5 | Sprocket 41B14 x 3/4" Bore No KW (2SS 5/16"-18) | 1 | 1 |
| MD00243 | 6 | #41 Chain (47 Links C/W Link) | 3 | 3 |
| MD00246 | 7 | 41B32-41B14 x 1" Sprocket with Brass Bushing | 1 | 1 |
| MD00247 | 8 | 41B32-41B14 x 3/4" Sprocket with Brass Bushing | 1 | 1 |
| MD00280 | 9 | 41B32 Sprocket with 1" Bore x 0.25" KW 2SS | 1 | 1 |
| ME00001 | 10 | Limit Shaft 3/8" - 1/2" x 9.75" | 1 | 1 |
| ME00002 | 11 | Pro-H/Pro-HHD Input Shaft 3/4" x 16.45" | 1 | 1 |
| ME00007 | 12 | Drive Shaft 1" x 15" | 1 | 1 |
| ME00017 | 13 | Keyway 1/4" SQ x 1-1/4" Long | 1 | 1 |
| ME00048 | 14 | Keyway 1/4" SQ x 3/4" Long | 1 | 1 |
| ME00050 | 15 | Frame Support Shaft 3/4" x 6" | 2 | 2 |
| MF00003 | 16 | R.H. Philips Machine Screw 4-40 UNC x 1-1/2" | 8 | 8 |
| MF00004 | 17 | R.H. Philips Machine Screw 6-32 UNC x 1" | 2 | 2 |
| MF00005 | 18 | R.H. Philips Machine Screw 10-32UNF x 5/8" | 1 | - |
| MF00006 | 19 | Hex Head Bolt 1/4"-20UNC x 1/2" | 2 | 2 |
| MF00008 | 20 | Hex Head Bolt 1/4"-20UNC x 1" | 1 | 1 |
| MF00009 | 21 | Hex Head Bolt 1/4" - 20UNC x 2-1/4" (Partial Thread) | 1 | 1 |
| MF00011 | 22 | Hex Head Bolt 3/8"-16UNC x 3/4" Long | 8 | 8 |
| MF00012 | 23 | Carriage Bolt 5/16-18UNC x 5/8" | 4 | 4 |
| MF00045 | 24 | Hex Head Slotted Self Rounding Washer Head Screw 8-32UNF x 3/8" | 4 | - |
| MF00046 | 25 | Hex Head Slotted Self Rounding Washer Head Screw 10-32UNF x 1/2" | 6 | 2 |
| MF00124 | 26 | HHB Ser Wash Type F Head Reg Thr #10-32 x 1/2" | 3 | 3 |
| MG00003 | 27 | Double Nut for Lim-Sw | 4 | 4 |
| MG00006 | 28 | Hex Nut 1/4-20UNC | 5 | 1 |
| MG00007 | 29 | Hex Nylon Lock Nut 6-32UNC | 2 | 2 |
| MG00008 | 30 | Hex Nylon Lock Nut 10-32UNF | 1 | - |
| MG00009 | 31 | Hex Nylon Lock Nut 1/4"-20UNC | 1 | 1 |
| MG00010 | 32 | Ribbed Hex Nut 10-32UNF | 6 | 2 |
| MG00011 | 33 | Ribbed Hex Nut 1/4"-20 | 3 | 3 |
| MG00012 | 34 | Ribbed Hex Nut 5/16-18UNC | 4 | 4 |
| MG00013 | 35 | Ribbed Hex Nut 3/8" -16 UNC | 4 | 4 |
| MG00014 | 36 | Slotted Hex Nut 3/4-24UNF | 1 | 1 |
| MG00016 | 37 | Flat Washer #10 | 2 | - |
| MG00017 | 38 | Flat Washer 0.25 ID x 0.5" OD | 2 | 2 |
| MG00018 | 39 | Lock Washer for 3/8" Screw | 4 | 4 |
| MG00019 | 40 | Flat Washer 13/16" ID x 1.5" OD | 1 | 1 |
| MG00020 | 41 | Flat Washer 1-1/16" ID x 1-3/4" OD | 1 | 1 |
| MG00021 | 42 | Flat Washer 7/8" ID x 1-1/8" OD | 5 | 5 |

| | | | | |
|---------|----|--|----|----|
| MG00030 | 43 | Limit Cam 1/2"-20UNF | 2 | 2 |
| MH00001 | 44 | T-Bushing 3/8" ID | 2 | 2 |
| MH00006 | 45 | Collar 3/8" ID - 3/4" OD | 1 | 1 |
| MH00007 | 46 | Collar 1" ID - 1.5" OD | 3 | 3 |
| MH00008 | 47 | Collar 3/4" ID - 1.25" OD | 3 | 3 |
| MH00009 | 48 | Flanged Bearing 1" ID x 2" OD | 2 | 2 |
| MH00013 | 49 | Flange Bearing 3/4"ID x 1-3/8" OD | 1 | 1 |
| MH00109 | 50 | Precision Flange Bearing 3/4" ID x 1-3/8" OD with Snap Ring | 1 | 1 |
| MH00158 | 51 | Bronze Flange T-Bushing MM00431 3/4" ID x 1" OD x 0.5" L w/ Clip | 1 | 1 |
| MI00001 | 52 | Motor Pulley 5L 5/8" ID x 2" OD | 1 | 1 |
| MI00002 | 53 | 5L Pulley 8" OD C/W Bushing 0.75" ID | 1 | 1 |
| MI00003 | 54 | Pocket Wheel C/W 2 Pins and Bushing 3/4" ID | 1 | 1 |
| MI00006 | 55 | V Belt 5L-325 | 1 | 1 |
| MJ00004 | 56 | Clutch Plate 0.75" ID | 1 | 1 |
| MJ00005 | 57 | Clutch Pad | 1 | 1 |
| MJ00006 | 58 | Limit Switch Double Spacer 3/4" | 4 | 4 |
| MJ00013 | 59 | Brake Assembly #1 (Standard Operator) | 1 | 4 |
| MK00004 | 60 | Limit Switch | 4 | 2 |
| MK00026 | 61 | Solenoid 120V | 1 | - |
| MK00027 | 61 | Solenoid 240V | 1 | - |
| MK00028 | 61 | Solenoid 460V | 1 | - |
| MK00029 | 61 | Solenoid 575V | 1 | - |
| MM00010 | 62 | HHD Brake Plate MSI0007 | 1 | - |
| MM00011 | 63 | Solenoid Cover | 1 | - |
| MM00014 | 64 | Solenoid Lever | 1 | - |
| MM00022 | 65 | Support U-Bracket | 1 | 1 |
| MM00024 | 66 | Cam Plate | 1 | 1 |
| MM00046 | 67 | Control Box Hinge | 2 | 2 |
| MM00150 | 68 | Frame | 1 | 1 |
| MM00151 | 69 | Frame Foot HR | 2 | 2 |
| MM00152 | 70 | Control Box | 1 | 1 |
| MM00153 | 71 | Control Box Cover | 1 | 1 |
| MM00155 | 72 | Disconnect Arm Pro-HR MSI0167 | 1 | 1 |
| MM00431 | 73 | Chain Guard | 1 | 1 |
| MM00493 | 74 | Pivot Bracket Hoist Left Pro-HB/Pro-HHD | 1 | - |
| MM00494 | 74 | Pivot Bracket Hoist Right Pro-HB/Pro-HHD | 1 | - |
| MO00001 | 75 | Cam Plate Compression Spring (0.178ID x 0.032G x 0.55L) | 2 | 2 |
| MO00003 | 76 | Compression Spring 0.8 ID x 0.092 WD x 1.8" L | 1 | 1 |
| MO00027 | 77 | Clutch Spring 0.812 ID x 0.218 WD x 1" - 4 Coil | 1 | 1 |
| MO00030 | 78 | Pro-HB/HHD Solenoid Extension Spring | 1 | - |
| MO00031 | 79 | Heavy Duty HHD/HB Brake Spring #12B | 1 | - |
| MQ00001 | 80 | Cotter Pin 1/8 x 1.5" | 1 | - |
| MQ00007 | 81 | Spring Pin 1/4" x 2" | 2 | 2 |
| MQ00008 | 82 | Set Screw 5/16"-18UNC | 16 | 14 |
| MQ00009 | 83 | Set Screw 1/4"-20 | 3 | 3 |
| MQ00011 | 84 | 3/32" Aluminum Oval Sleeves | 2 | 1 |
| MQ00020 | 85 | Spring Pin 3/16" x 1-3/4" Long | 1 | 1 |
| MQ00049 | 86 | Cotter Pin 1/8" x 2" | 1 | 1 |
| MR00001 | 87 | 3/32" Cable 13" Long C/W Cable Stop | 1 | - |
| MR00006 | 88 | Hand Chain Door Height | 1 | 1 |
| MR00008 | 89 | Disconnect Sash Chain | 1 | 1 |
| MR00040 | 90 | Cable 24" Long With Stopper | 1 | 1 |
| MR00001 | 90 | 3/32" Cable 13" Long C/W Cable Stop | 1 | 1 |
| MU00001 | 91 | Swivel Pulley | 1 | - |
| MU00002 | 92 | Keyring 1-1/4" | 1 | 1 |
| MU00012 | 93 | Double Cable Clamp Pro-HB/HHD | 1 | - |

MS-100-IM-WW 1-Phase Wiring Diagram

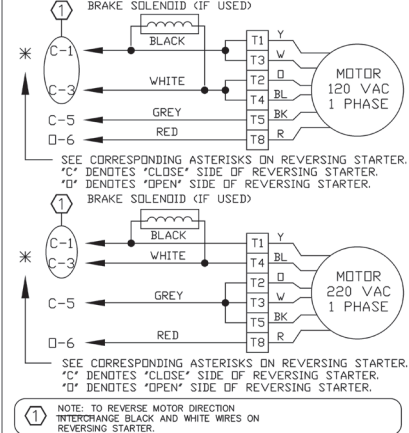
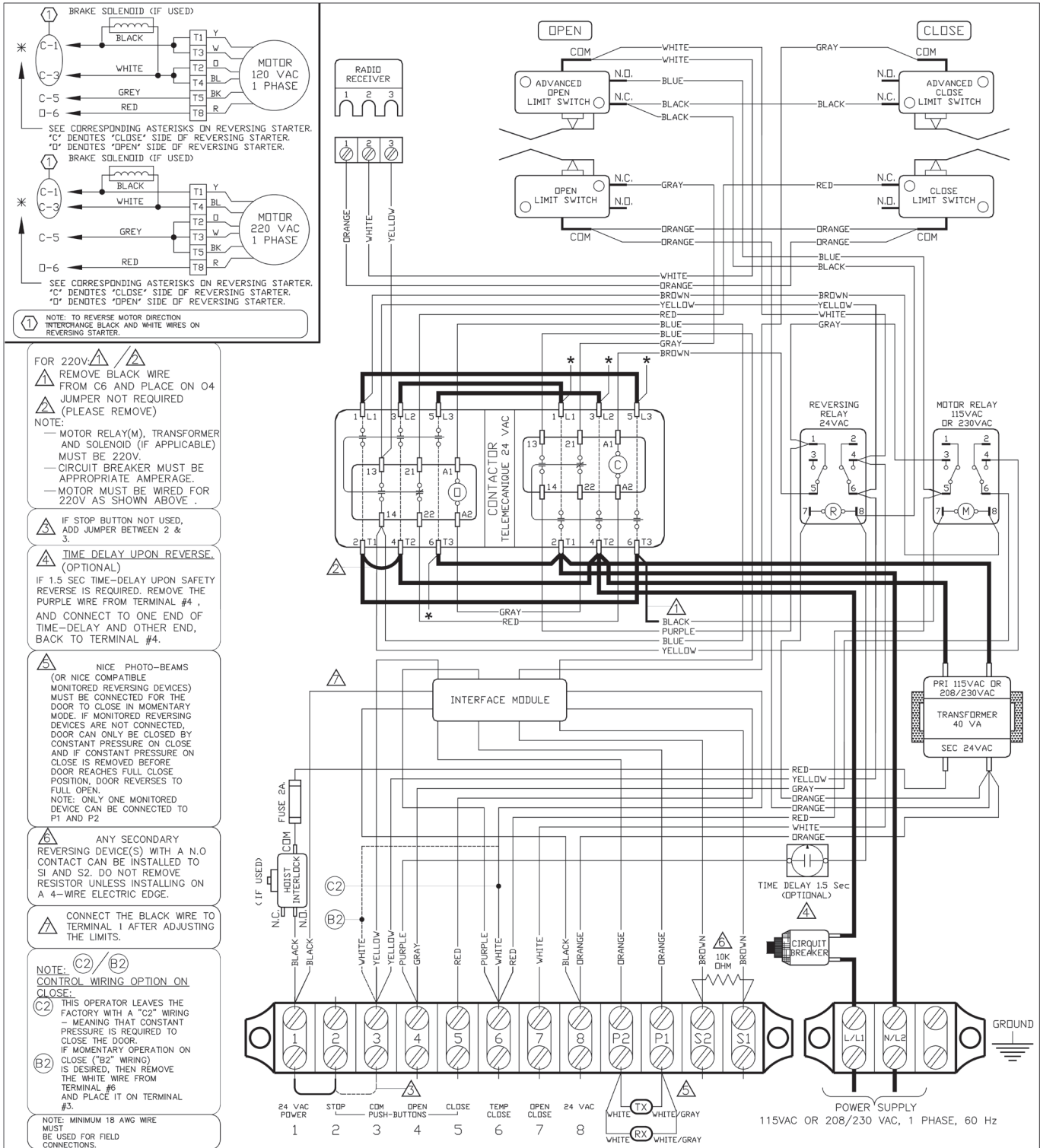

- FOR 220V: REMOVE BLACK WIRE FROM C6 AND PLACE ON O4 JUMPER NOT REQUIRED (PLEASE REMOVE)
- NOTE:
 - MOTOR RELAY(M), TRANSFORMER AND SOLENOID (IF APPLICABLE) MUST BE 220V.
 - CIRCUIT BREAKER MUST BE APPROPRIATE AMPERAGE.
 - MOTOR MUST BE WIRED FOR 220V AS SHOWN ABOVE.
- IF STOP BUTTON NOT USED, ADD JUMPER BETWEEN 2 & 3.
- TIME DELAY UPON REVERSE (OPTIONAL)
 - IF 1.5 SEC TIME-DELAY UPON SAFETY REVERSE IS REQUIRED, REMOVE THE PURPLE WIRE FROM TERMINAL #4, AND CONNECT TO ONE END OF TIME-DELAY AND OTHER END, BACK TO TERMINAL #4.
- NICE PHOTO-BEAMS (OR NICE COMPATIBLE MONITORED REVERSING DEVICES) MUST BE CONNECTED FOR THE DOOR TO CLOSE IN MOMENTARY MODE. IF MONITORED REVERSING DEVICES ARE NOT CONNECTED, DOOR CAN ONLY BE CLOSED BY CONSTANT PRESSURE ON CLOSE AND IF CONSTANT PRESSURE ON CLOSE IS REMOVED BEFORE DOOR REACHES FULL CLOSE POSITION, DOOR REVERSES TO FULL OPEN. NOTE: ONLY ONE MONITORED DEVICE CAN BE CONNECTED TO P1 AND P2.
- ANY SECONDARY REVERSING DEVICE(S) WITH A N.O CONTACT CAN BE INSTALLED TO S1 AND S2. DO NOT REMOVE RESISTOR UNLESS INSTALLING ON A 4-WIRE ELECTRIC EDGE.
- CONNECT THE BLACK WIRE TO TERMINAL 1 AFTER ADJUSTING THE LIMITS.
- NOTE: CONTROL WIRING OPTION ON CLOSE:
 - THIS OPERATOR LEAVES THE FACTORY WITH A "C2" WIRING - MEANING THAT CONSTANT PRESSURE IS REQUIRED TO CLOSE THE DOOR.
 - IF MOMENTARY OPERATION ON CLOSE ("B2" WIRING) IS DESIRED, THEN REMOVE THE WHITE WIRE FROM TERMINAL #6 AND PLACE IT ON TERMINAL #3.
- NOTE: MINIMUM 18 AWG WIRE MUST BE USED FOR FIELD CONNECTIONS.

1-Phase Wiring Diagram
MS100-IM-WW
 REV. J DATE: 03.12.20
 TECH. HELP LINE:
 CANADA: 1-(877) 888-1116
 USA: 1-(888) 816-8584

Nice
Nice Group Canada Inc.
 1380 St Regis Blvd, Dorval, QC H9P 2T5

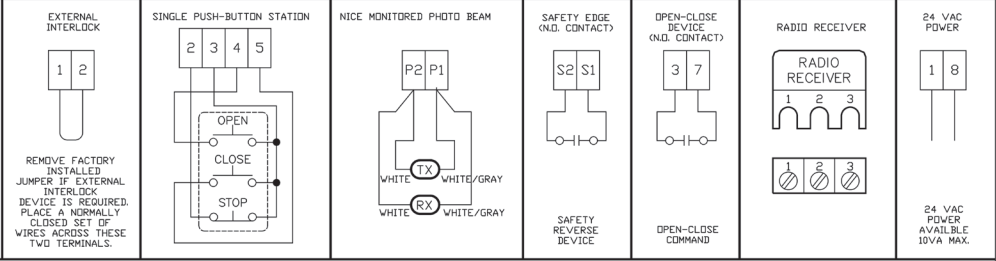

This drawing is strictly confidential and reserved by law. The total or partial reproduction without authorization is prohibited/forbidden

MSL100-110V-WW 1-Phase Wiring Diagram

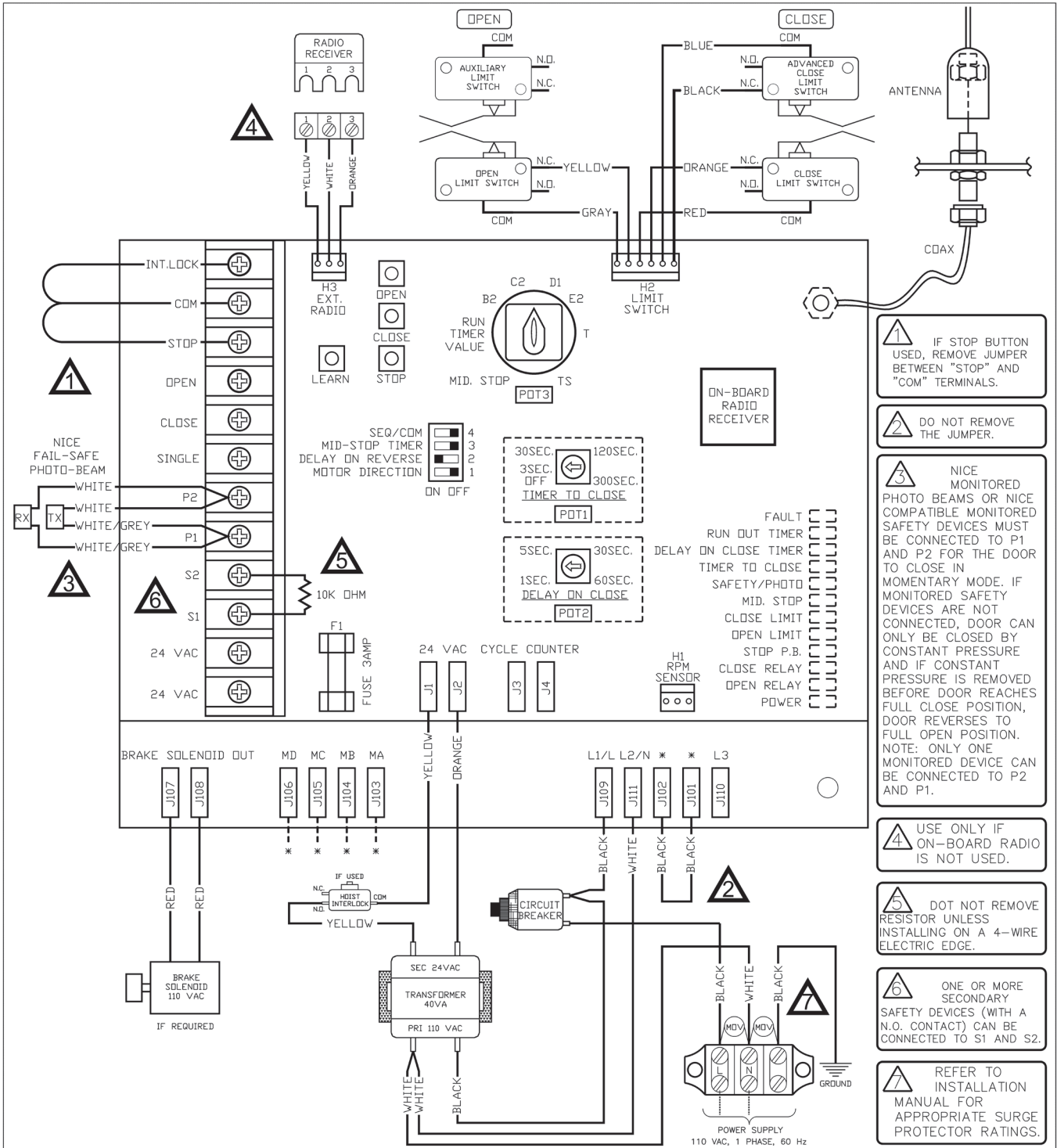

1-Phase Wiring Diagram 110V
MSL100-110V-WW
REV. E | DATE: 20.02.20
TECH. HELP LINE:
CANADA: 1-(877) 888-1116
USA: 1-(888) 816-8584

Nice

Nice Group Canada Inc.
1380 St Regis Blvd, Dorval, QC H9P 2T5

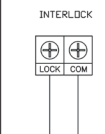

REMOVE FACTORY INSTALLED JUMPER IF EXTERNAL INTERLOCK DEVICE IS REQUIRED. PLACE A NORMALLY CLOSED SET OF WIRES ACROSS THESE TWO TERMINALS.

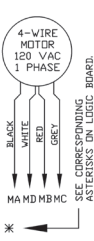
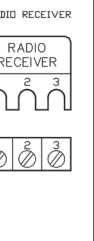
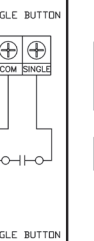
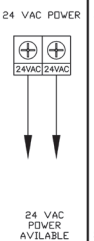
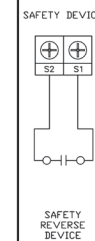
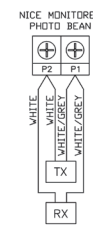
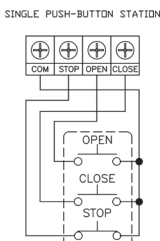

MS300-WW 3-Phase Wiring Diagram

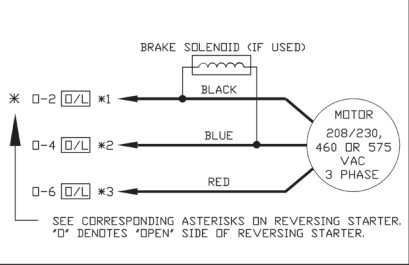

NOTE: (1)
TO REVERSE MOTOR DIRECTION INTERCHANGE ANY 2 OF THE 3 INCOMING POWER LINES CONNECTING TO POWER SUPPLY TERMINAL STRIP L1, L2, L3.

NOTE: (C2)/(B2)
CONTROL WIRING OPTION ON CLOSE.

(C2) THIS OPERATOR LEAVES THE FACTORY WITH A "C2" WIRING - MEANING THAT CONSTANT PRESSURE IS REQUIRED TO CLOSE THE DOOR.

(B2) IF MOMENTARY OPERATION ON CLOSE ("B2" WIRING) IS DESIRED, THEN REMOVE THE WHITE WIRE FROM TERMINAL #5 AND PLACE IT ON TERMINAL #3.

⚠ TIME DELAY UPON REVERSE.
IF 1.5 SEC TIME-DELAY UPON SAFETY REVERSE IS REQUIRED, REMOVE THE PURPLE WIRE FROM TERMINAL #4, AND CONNECT TO ONE END OF TIME-DELAY AND OTHER END, BACK TO TERMINAL #4.

⚠ IF STOP BUTTON NOT USED, ADD JUMPER BETWEEN 2 & 3.

⚠ WARNING
NICE STRONGLY RECOMMENDS THE USE OF ENTRAPMENT PROTECTION SYSTEMS WHEN B2 (MOMENTARY CONTACT) WIRING IS USED.

NOTE: MINIMUM 18 AWG WIRE MUST BE USED FOR FIELD CONNECTIONS.

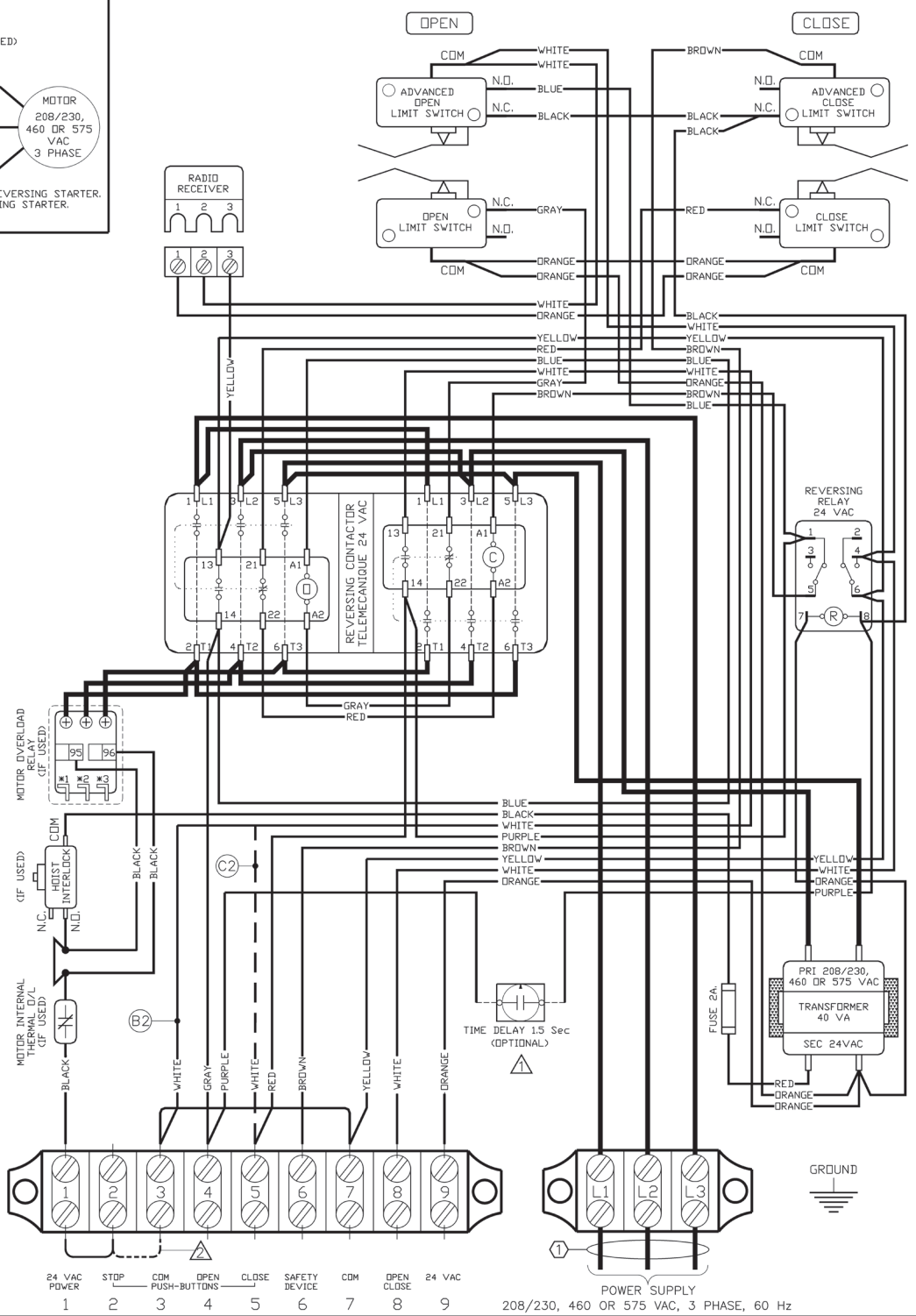

3-Phase Wiring Diagram
MS300-WW
REV. 1 DATE: 20.02.20
TECH. HELP LINE:
CANADA: 1-(877) 888-1116
USA: 1-(888) 816-8584



Nice Group Canada Inc.
1380 St Regis Blvd, Dorval, QC H9P 2T5

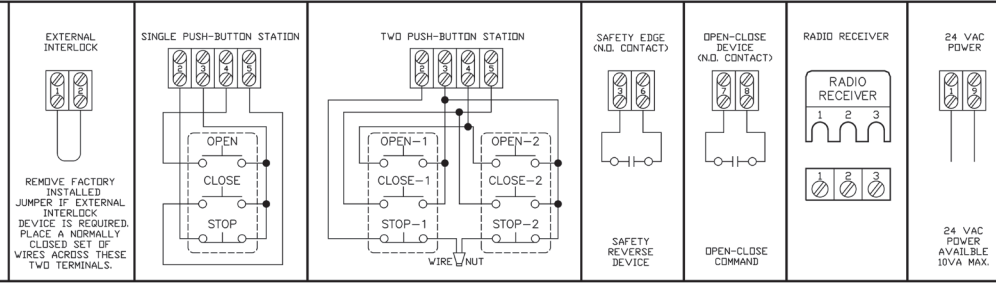

This drawing is strictly confidential and reserved by law. The total or partial reproduction without authorization is prohibited/forbidden

MS300-IM-WW 3-Phase Wiring Diagram

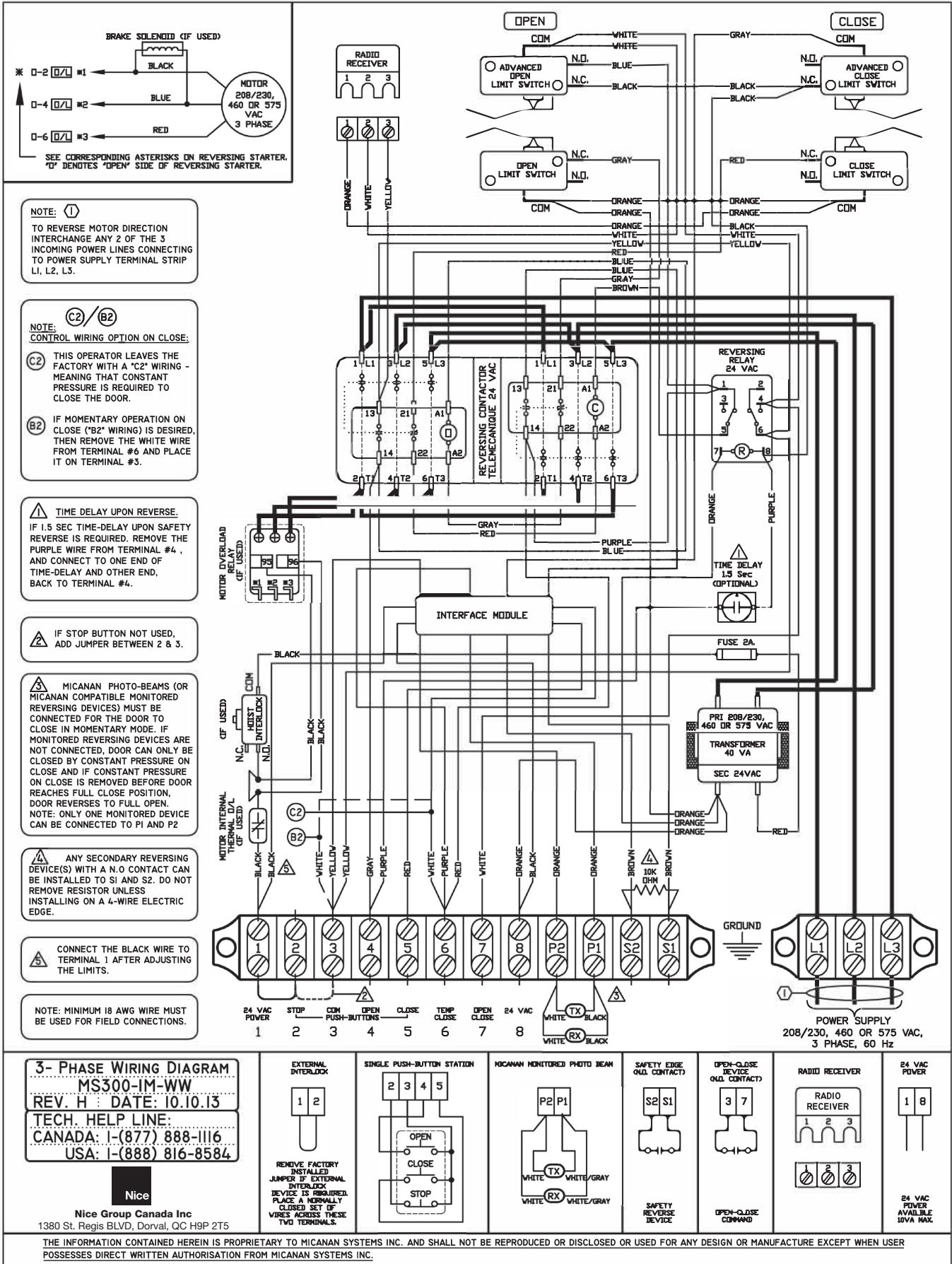

MSL300-WW 3-Phase Wiring Diagram

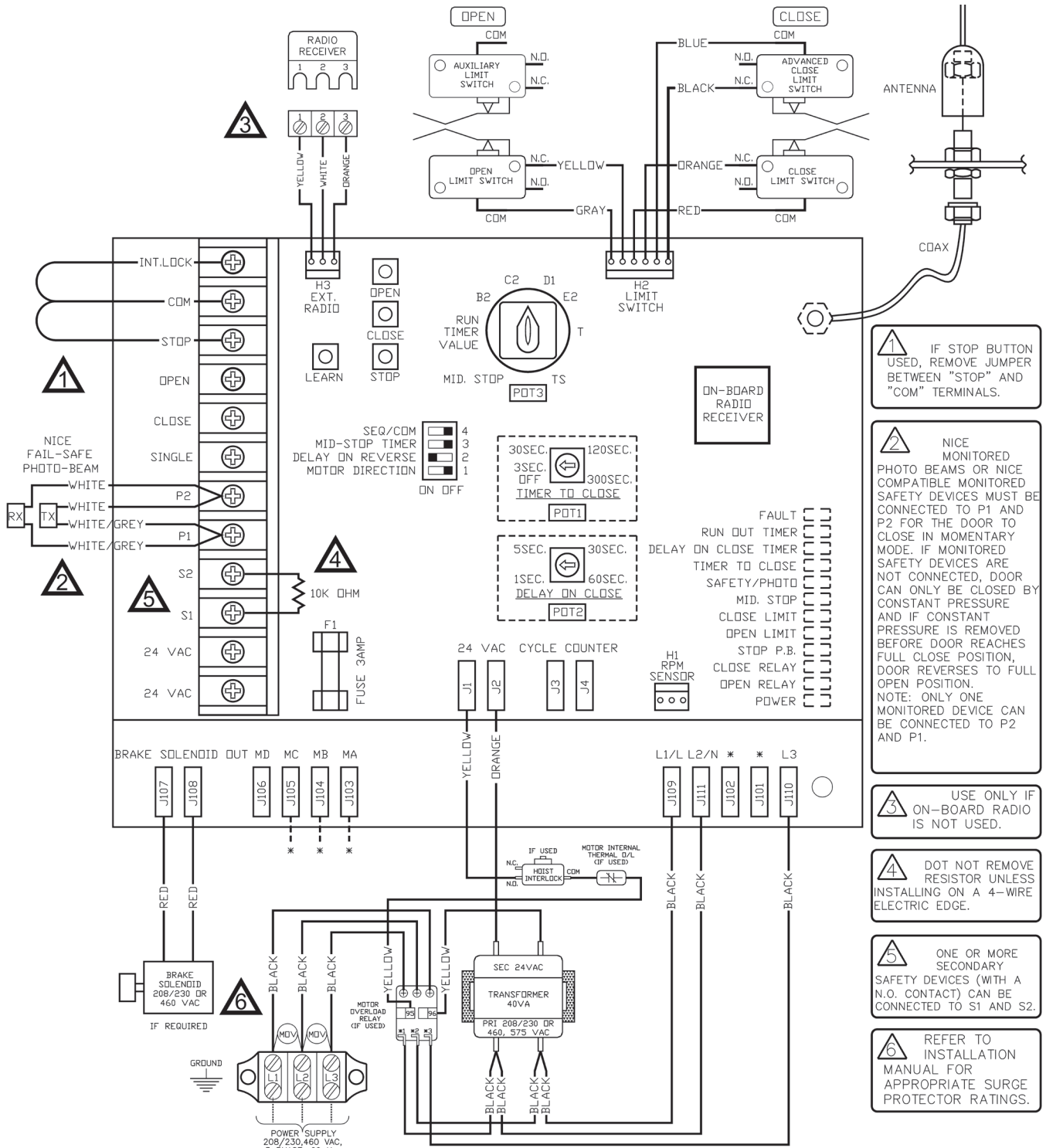

3-Phase Wiring Diagram
 MSL300-WW
 REV. G DATE: 20.02.20
 TECH. HELP LINE:
 CANADA: 1-(877) 888-1116
 USA: 1-(888) 816-8584



Nice Group Canada Inc.
 1380 St Regis Blvd, Dorval, QC H9P 2T5

| | | | | | | | |
|--|-----------------------------------|----------------------------------|--|---|--|-----------------------|---|
| <p>INTERLOCK</p> <p>REMOVE FACTORY INSTALLED JUMPER IF EXTERNAL INTERLOCK DEVICE IS REQUIRED. PLACE A NORMALLY CLOSED SET OF WIRES ACROSS THESE TWO TERMINALS.</p> | <p>SINGLE PUSH-BUTTON STATION</p> | <p>NICE MONITORED PHOTO BEAM</p> | <p>SAFETY DEVICE</p> <p>SAFETY REVERSE DEVICE (N.D. CONTACT)</p> | <p>24 VAC POWER</p> <p>24 VAC POWER AVAILABLE 10 VA, MAX.</p> | <p>SINGLE BUTTON</p> <p>SINGLE BUTTON (N.D. CONTACT)</p> | <p>RADIO RECEIVER</p> | <p>MOTOR 208/230, 460, 575 VAC 3 PHASE</p> <p>SEE CORRESPONDING ASTERISKS ON LOGIC BOARD.</p> |
|--|-----------------------------------|----------------------------------|--|---|--|-----------------------|---|

This drawing is strictly confidential and reserved by law. The total or partial reproduction without authorization is prohibited/forbidden

MSLC300-WW 3-Phase Wiring Diagram

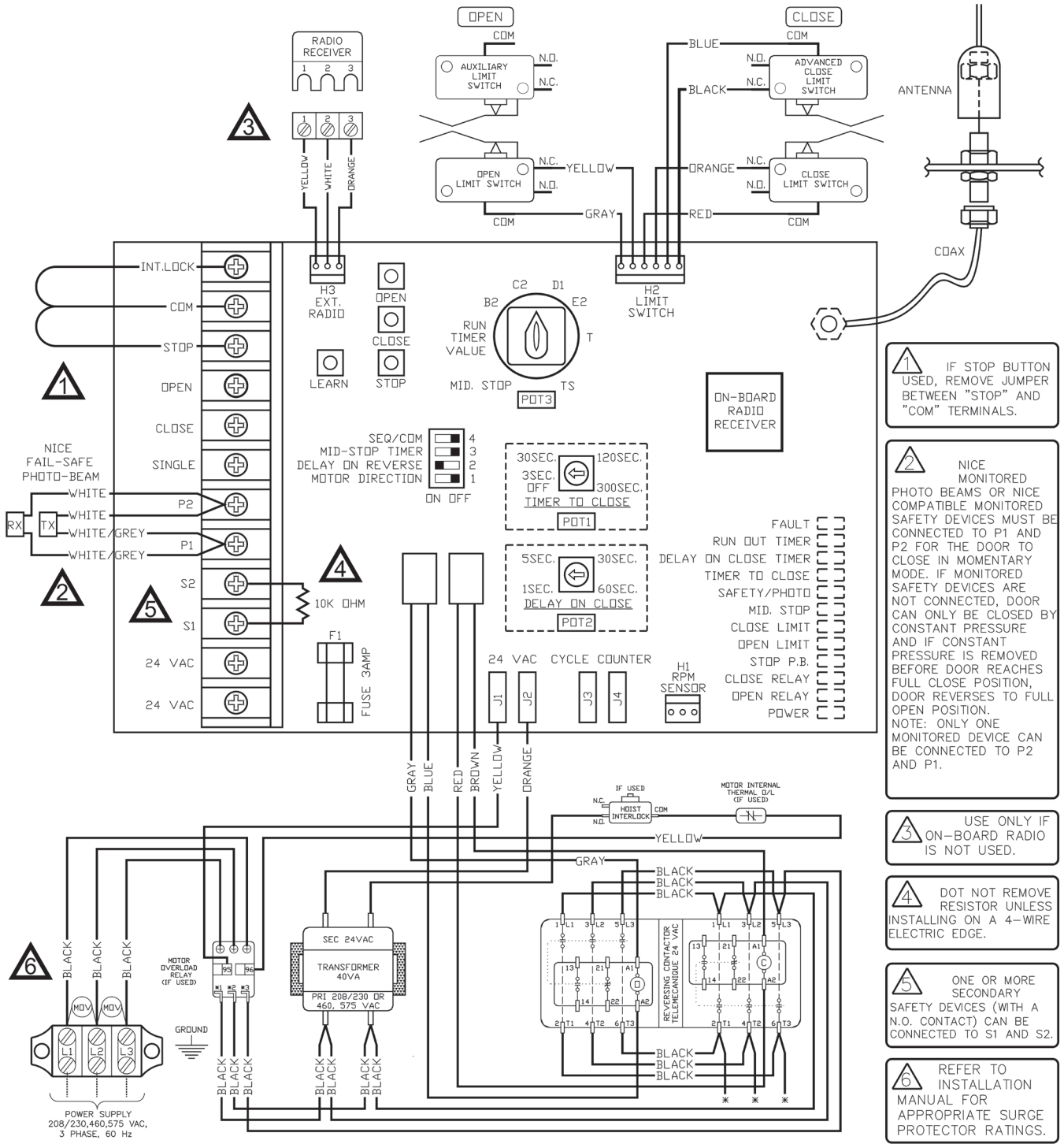

3-Phase Wiring Diagram
 MSLC300-WW
 REV. G DATE: 20.02.20
 TECH. HELP LINE:
 CANADA: 1-(877) 888-1116
 USA: 1-(888) 816-8584

Nice

Nice Group Canada Inc.
 1380 St Regis Blvd, Dorval, QC H9P 2T5

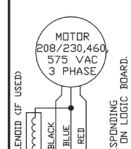
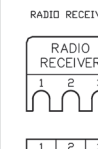
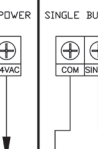
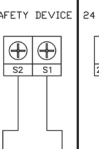
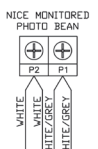
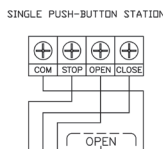
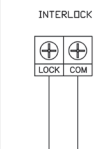

HOW TO ORDER REPAIR PARTS

DEVANCO  CANADA

19192 HAY ROAD, UNIT Q
SUMMERSTOWN, ON, K0C 2E0

TOLL FREE **1-855-931-3334**
WWW.DEVANCOCANADA.COM

**WHEN ORDERING REPAIR PARTS
PLEASE SUPPLY THE FOLLOWING INFORMATION:**

- ✓ **PART NUMBER**
- ✓ **DESCRIPTION**
- ✓ **MODEL NUMBER**