

Addendum – Rapido High-Speed Operators

This addendum is to be used in conjunction with the Installation & Instruction Manual.

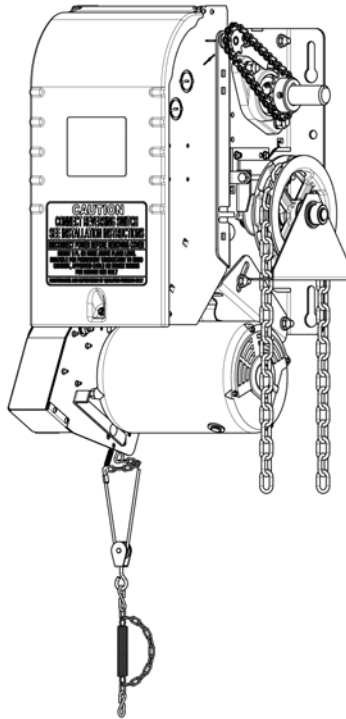

RSH
(Rapido SH)

High-Speed Operators Designed for
Fast Doors
RSH

READ AND FOLLOW ALL INSTRUCTIONS.
SAVE THESE INSTRUCTIONS.
GIVE TO END-USER.

Serial # _____

Model # _____

Wiring Diagram # _____

Project #/Name _____

Door #/Name _____



For more information, visit www.devancocanada.com or call toll free at 855-931-3334

TABLE OF CONTENTS

Installation Instructions.....	3
1 General Specifications and Dimensions (RSH).....	4
2 Limit Switches & Limit Cams: Adjustment & Functionality.....	5
2.1 Limit Switch Adjustments: Open and Close Cam Settings.....	5
2.2 Limit Switch Functionality.....	5
2.3 Limit Switch Adjustment Using Manual Hand Chain.....	6
2.4 Low Voltage (Controls) and High Voltage (Power) Connections.....	7
2.5 Main Power Supply Connection.....	7
3 Electrical Drawings.....	8
3.1 Rapido Operators and BOARD 070.....	8
Warranty.....	9
Notes.....	10

Installation Instructions

IMPORTANT INSTALLATION INSTRUCTIONS

WARNING

TO REDUCE THE RISK OF SEVERE INJURY OR DEATH TO PERSONS:

1. READ AND FOLLOW ALL INSTALLATION INSTRUCTIONS.
2. Install only on a properly operating and balanced door. A door that is operating improperly could cause severe injury. Have qualified service personnel make repairs to cables, spring assemblies and other hardware before installing the operator.
3. Remove all pull ropes and remove, or make inoperative, all locks (unless mechanically and/or electrically interlocked to the power unit) that are connected to the door before installing the operator.
4. Installation of this door operator must be done by a qualified installer.
5. Verify that the operator is correct for type, size of door and frequency of use per the operator specifications.
6. Install the door operator at least 8 feet (2,4 m) or more above the floor if the operator has exposed moving parts.
7. Do not connect the door operator to the source of power until instructed to do so.
8. Locate the control station: (a) within sight of the door, (b) at a minimum height of 5 feet (1,5 m) so small children cannot reach it, and (c) away from all moving parts of the door.
9. Install the Entrapment Warning Placard next to the control station in a prominent location.
10. For products having a manual release, instruct the end user on the operation of the manual release.
11. If you have any questions about the safety of the door operating system, do not install the operator, contact Manaras-Opera at 1-800-361-2260.

1 General Specifications and Dimensions (RSH)

SUPPLY VOLTAGE.....	115 VAC single-phase
CONTROL VOLTAGE.....	24 VAC class 2 transformer, 2 amp fuse type ACG
MOTOR.....	Continuous duty 1/2, 1 horsepower
MOTOR VOLTAGE.....	208 VAC three-phase
OPERATOR OUTPUT SPEED.....	88 RPM
NET WEIGHT (Operator only).....	96 Lbs (44 Kg)
STANDARD WIRING TYPE.....	C2 (momentary contact to open/stop and constant-pressure-to-close)
APPLICATION.....	Ultra high-end heavy duty v-belt drive for sectional doors
DUTY.....	>100 cycles/day

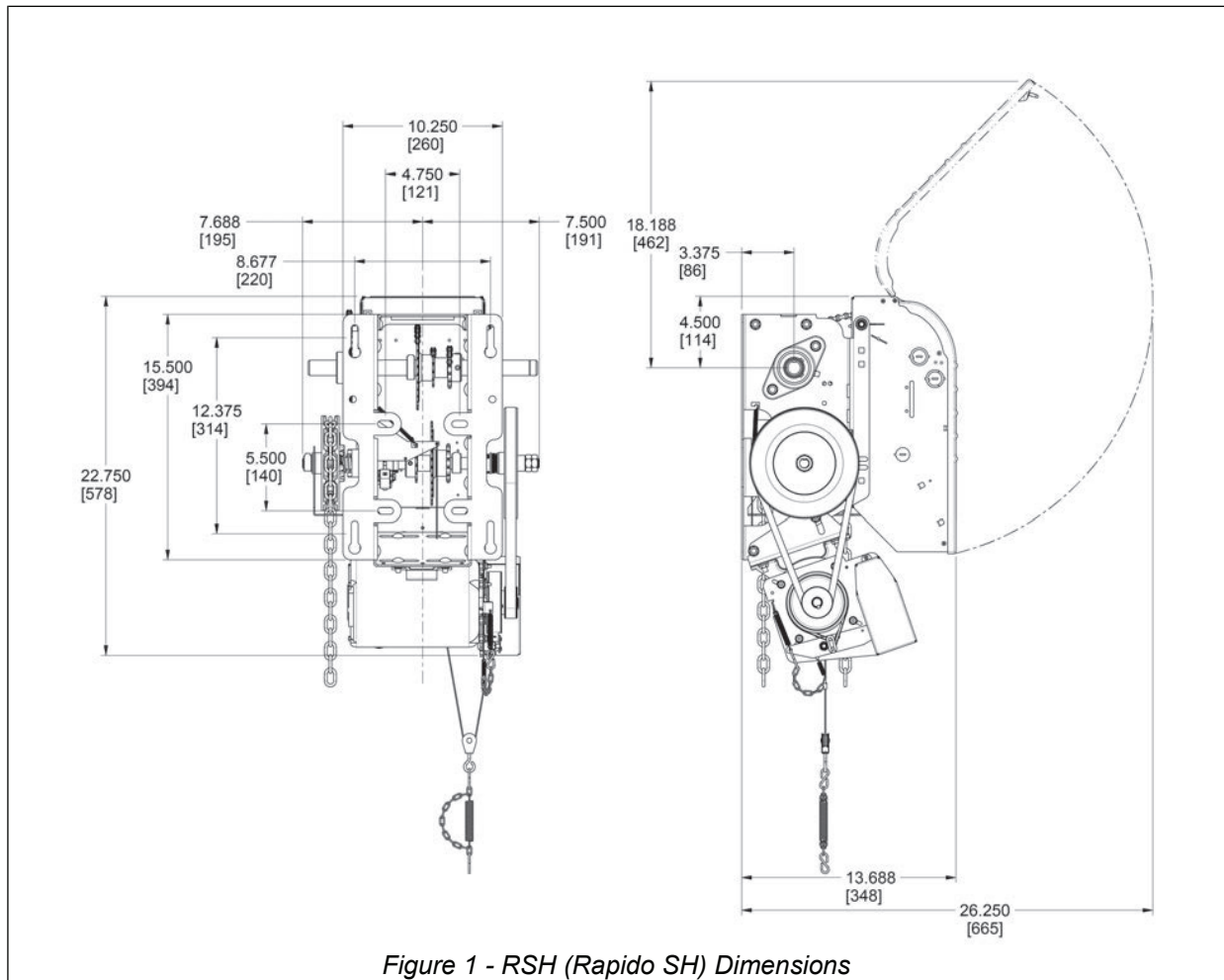

Figure 1 - RSH (Rapido SH) Dimensions

Maximum Door Size: To be evaluated based on the door speed required.

2 Limit Switches & Limit Cams: Adjustment & Functionality

⚠ WARNING

To reduce risk of SEVERE INJURY or DEATH to persons:

- Do not attempt to make limit switch adjustments unless power has been electrically disconnected.
- The adjustment of the deceleration limit may affect the door's stop position.

2.1 Limit Switch Adjustments: Open and Close Cam Settings

This operator is equipped with the **ACCU-CAM®** feature, for precise and quick one-handed limit setting adjustments.

To adjust the limit cams, see Figure 2.

1. Pull the cam's retaining bracket back.
2. Turn the cams for limit adjustment: turning cams toward the center of the limit shaft increases door travel or turning the cams toward the limit switch decreases door travel.

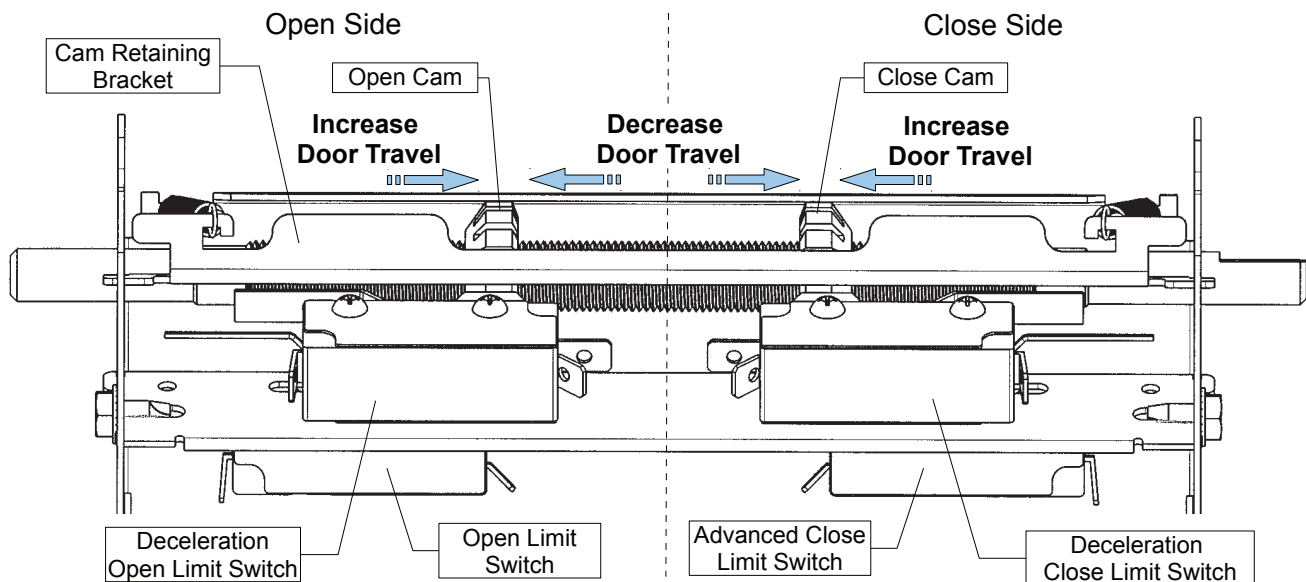

Figure 2 - Limit Switches and Cams Adjustment

2.2 Limit Switch Functionality

Open Limit Switch

When activated, the Open Limit Switch will stop the operator while the door is travelling in the upward direction. Should be adjusted accordingly to stop door in fully open position.

Close Limit Switch and Advanced Close Limit Switch

Close Limits are not present on operators with an ECB. In its place, the microprocessor has a built-in patented Advanced Close Time feature. While the door is travelling downwards and once the Advanced Close Limit Switch is activated, the door will stop after **200 milliseconds**. The distance travelled varies according to the speed of the door. The value is fixed and cannot be re-programmed or adjusted.

Deceleration Limit Switch

The operator is provided with a **Variable Frequency Drive**. The deceleration time is factory set, however it can be adjusted on-site using the Deceleration Limit Switches (Open and Close).

2.3 Limit Switch Adjustment Using Manual Hand Chain

Table 1 - Limit Switch Adjustment Procedures

Limit Switch	Adjustment Procedures
Open Limit	<ol style="list-style-type: none"> 1. Using the hoist, manually raise the door to a nearly opened position or desired open position. 2. Pull the cam-retaining bracket from the Open side, see Figure 2, and rotate the Open cam manually until it activates the Open Limit Switch sufficiently so that a “click” can be heard. 3. Release the cam-retaining bracket and make sure that the bracket engages in the slots of both cams.
Advanced Close Limit	<ol style="list-style-type: none"> 1. Using the hoist, manually lower the door to approx. 6” above the ground. 2. Pull the cam-retaining bracket from the Close side, see Figure 2, and rotate Close cam manually until it activates the Close limit switch sufficiently so that a “click” can be heard. 3. Release the cam-retaining bracket and make sure that the bracket engages in the slots of both cams.
Limit Switch Fine Adjustment	<ol style="list-style-type: none"> 1. Limit switch fine adjustment SHOULD be done after the main power supply is connected to the operator. Note: One (1) notch on cam is equal (=) to about ½” of the door travel.

NOTICE

- The installer **MUST** test for proper connection and functionality of the operator and its accessories before leaving the job site.
- The installer should also perform a demonstration for the end-user.

2.4 Low Voltage (Controls) and High Voltage (Power) Connections

1. Route the main power line wires either from the right or from the left of the control panel, as shown in Figure 3.
2. Route all low voltage control wires, as shown in Figure 3. **KEEP LOW VOLTAGE WIRES SEPARATE FROM LINE VOLTAGE WIRES.**
3. **USE COPPER CONDUCTORS ONLY.**

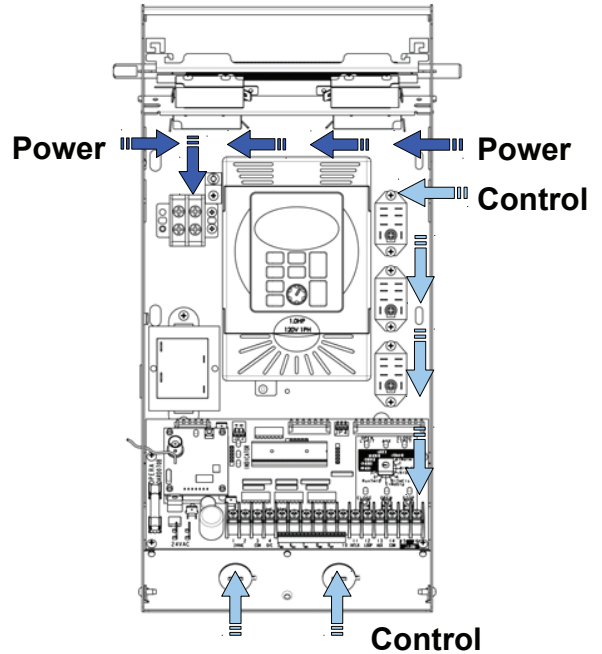
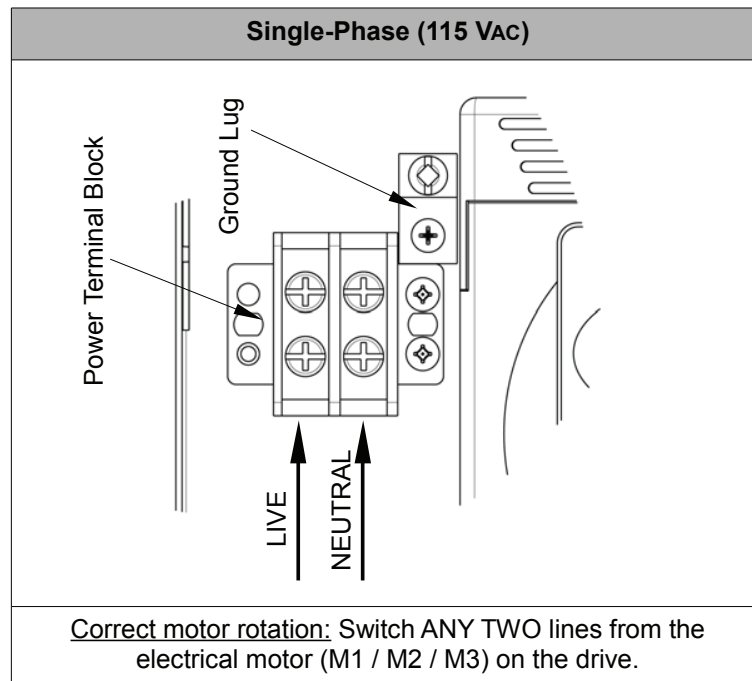

Figure 3 - Low Voltage (Controls) and High Voltage (Power) Connections

2.5 Main Power Supply Connection



3 Electrical Drawings

3.1 Rapido Operators and BOARD 070

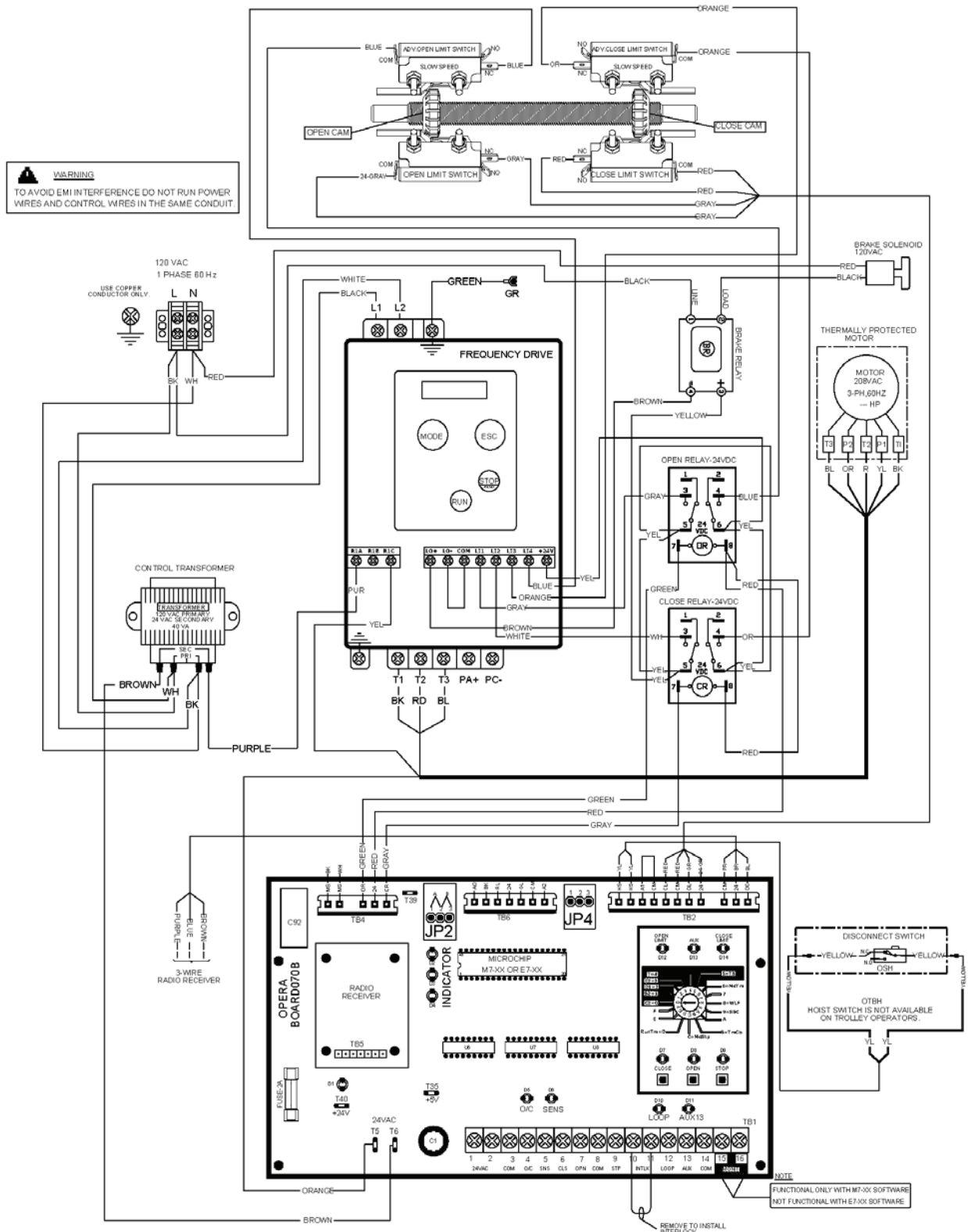

Figure 4 - EDWG14070VFD01

Warranty

Manaras-Opera warrants its operators to be free from defects in material and workmanship under normal and proper use for a period of two years from date of invoice, unless otherwise stated. Mechanical, electrical and electronic accessories are warranted for one year from date of invoice, unless otherwise stated. Wearing parts such as clutch pads, v-belts, and brake bands are excluded from warranty.

Manaras-Opera's only obligation shall be to repair or replace defective equipment which does not conform to the warranty. Manaras-Opera shall not be liable for any injury, loss or damage, direct or consequential, arising out of the inability to use the equipment. Before using, Buyer and/or the ultimate User shall determine the suitability of the product for its intended use, and User assumes all risks and liability in connection therewith. The foregoing may not be changed except by an Agreement signed by an authorized representative of Manaras-Opera.

The articles that are replaced pursuant to the terms of this warranty shall be retained by Manaras-Opera, and the User is responsible for any freight costs relating to repair or replacement.

The foregoing warranty is exclusive and in lieu of all other warranties of quality, whether written, oral or implied (including any other warranty of merchantability or fitness for purpose).

The following are exclusions from warranty:

- If usage, product modification, adaptation or installation are not in accordance with our installation and operating instructions.
- If the product has been opened, dismantled or returned with clear evidence of abuse or other damage.
- If our written specifications are not properly applied by the Buyer when selecting the equipment.
- If our written instructions for installation and wiring of the electrical connections have not been followed.
- If our equipment has been used to perform functions other than the functions it was designed to handle.
- If Manaras-Opera equipment is used with electrical accessories (switches, relays, etc.) that have not been previously approved in writing by the Manaras-Opera Engineering Department.
- If electrical accessories and other components have been used in disregard of the basic wiring diagram for which they were designed.

All costs related to installation and reinstallation of the Manaras-Opera equipment covered by this warranty are not the responsibility of Manaras-Opera. Manaras-Opera will not be responsible for any consequential damages following installation procedures performed by the Buyer or the User. If the Buyer resells any Manaras-Opera products to another Buyer or User, it shall include all of the terms and provisions of this warranty in such resale. Manaras-Opera's responsibility to any such Third Party shall be no greater than Manaras-Opera's responsibility under the warranty to the original Buyer.

Returns

No returns will be accepted without prior written authorization by Manaras-Opera. All returns must be accompanied by a Return Authorization Number issued by Manaras-Opera, and all unauthorized returns will be refused. The return shipment is to be freight prepaid by the Buyer, and under no circumstances shall the Buyer deduct the value of the returned merchandise from any remittance due. A restocking fee of 15% of the Manaras-Opera sale price will be charged for all returns not covered under warranty.

Notes

HOW TO ORDER REPAIR PARTS

DEVANCO CANADA

19192 HAY ROAD, UNIT Q
SUMMERSTOWN, ON K0C 2E0

TOLL FREE: 855-931-3334
www.devancocanada.com

**WHEN ORDERING REPAIR PARTS
PLEASE SUPPLY THE FOLLOWING INFORMATION:**

- ✓ PART NUMBER
- ✓ DESCRIPTION
- ✓ MODEL NUMBER