



## Instruction Manual

This thru beam photoeye is an external entrapment protection device type B1, non-contact sensor for use with automatic gates and doors. The photoeye provides a signal from the RX (receiver) to the gate or door operator that the beam is, or is not obstructed. The IRB-4X-2 operates up to 115 feet. The red alignment indicator on the RX provides status information at a glance, making set-up and alignment easy.

### Cautions and Warnings



This product is an accessory or part of a system. Install the IRB-4X-2 according to instructions from the gate or door operator manufacturer. Comply with all applicable codes and safety regulations.

The IRB-4X-2 is not UL compliant. This photoeye will not work with gate or door operators that require monitored safety devices.

### Specifications

Operating Range	Up to 115 ft. (35 m)
Power	12-24 VDC/AC
Current Draw of Transmitter	13 mA
Current Draw of Receiver	35 mA standby, 13 mA detect
Surge Protection	MOV
Relay Output Configuration	Form C contacts (NO, COM, NC)
Relay Contact Rating	1 A at 24 VDC
Operating Temperature	-40° to 170°F (-40° to 77°C)
Dimensions (L x W x H)	3.6" (91 mm) x 2.9" (74 mm) x 2.9" (74 mm)
Connections	"Removable" screw terminal for easy wiring



### Ordering Information

- IRB-4X2 EMX-1250-1
- IRB-MON2-4X2-HD-GREY (Grey powder-coated aluminum protective hoods) EMX-1915-1
- IRB-MON2-4X2-HD-GOLD (Gold powder-coated aluminum protective hoods). EMX-1916-1
- Universal Mounting Bracket HRD-288-1

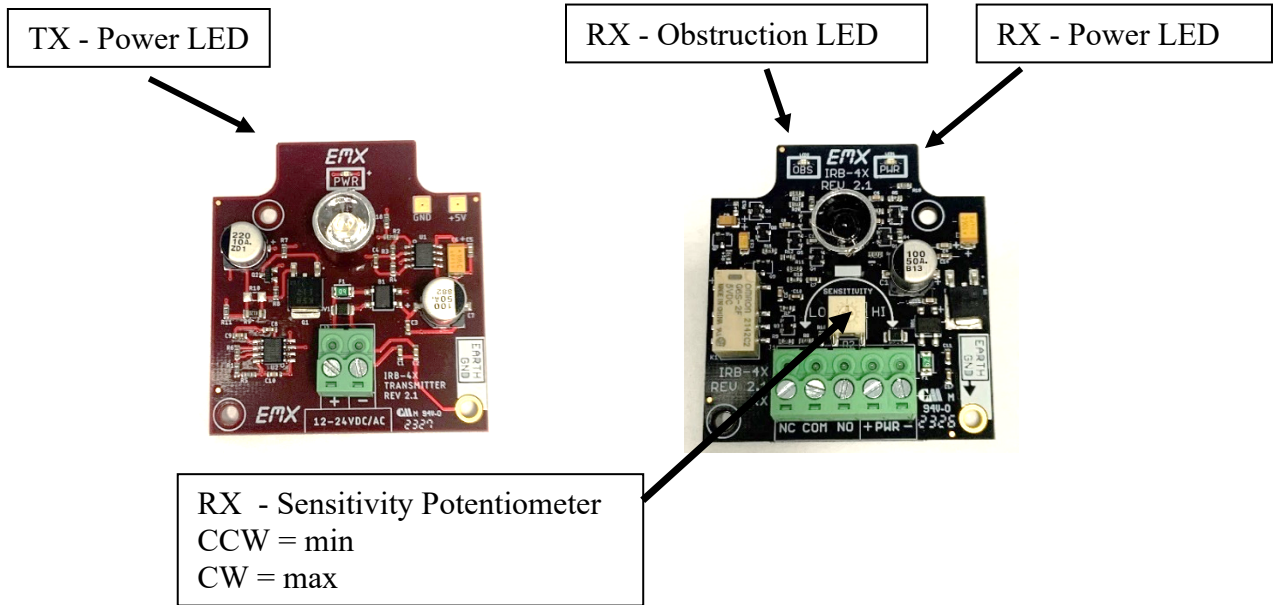
## Board Diagram



## Installation

<p>1. <b>MOUNTING:</b> Remove the covers. Determine your mounting height and mount housing with 4 screws (not supplied) that go through the inside of the 4 corner holes in the housing (the same holes where the plastic cover screws came out of).</p>	 <p>Optional Sunshield</p>  <p>Sunshield Installed</p>
<p>2. <b>WIRING:</b> Pull up on and remove the green screw terminal for easy wiring. Connect 12-24 VDC/AC power to the "+ -" TX (transmitter) terminals and "+ PWR -" RX (receiver) terminal. The power input terminals are not polarity sensitive. Wire the relay COM and then either the NC or NO to the operator per the operator manual.</p>	
<p>3. <b>OPTIONAL:</b> You may install the optional sunshield on the receiver as shown to the right in case of sun interference or cross talk.</p>	
<p>4. <b>POWER:</b> Apply power to the TX and RX.</p>	
<p>5. <b>SENSITIVITY:</b> Adjust the sensitivity potentiometer as needed by turning clockwise to increase gain or counter clockwise to decrease. Use the minimum sensitivity setting needed to achieve reliable detection.</p>	

**6. TEST OBSTRUCTION:** Place an obstruction (such as your hand) between the TX and RX and the RX's OBS LED should TURN ON when obstructed (and turn off when not obstructed and aligned). Test at different distances.

LED Indicators	
Transmitter PWR - Green LED on	Power
Receiver PWR - Green LED on	Power
Receiver OBS - Red LED on	Beam blocked or not aligned

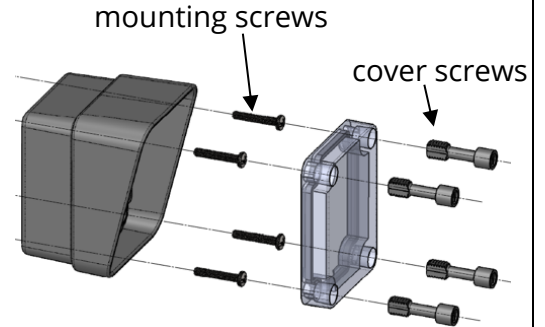

**7. TEST OPERATOR FUNCTIONALITY:** Power up the entire gate or door system and ensure the photoeye properly stops the system when obstructed.

- TIP:**
- If IRB-4X-2 is aligned but not detecting an obstruction, consider slowly reducing the RX sensitivity (counter-clockwise) until the obstruction is detected. This may be applicable for installations with a detection zone of less than 20 ft.

On some variable frequency drives and noisy installations, it may be necessary to connect the RX bottom right circuit board mounting hole labeled "Earth Ground" to a wire connected to earth ground. **Do not connect unless necessary. The majority of the time this is not needed.**

**8. SECURE COVERS:** Using the provided plastic screws secure the cover snug (don't overtighten them).

## Troubleshooting

Symptom	Possible Cause	Solution
Does not detect obstruction	Sensitivity is too high  Signal is reflecting off another surface	Decrease sensitivity (potentiometer counter clockwise).  Check area for highly reflective surfaces.
Receiver red LED on continuously, indicating an obstruction when one is not present	Sensitivity is too low  Transmitter does not have power  Receiver does not "see" transmitter	Increase sensitivity (potentiometer clockwise).  Check power source of transmitter.  Make sure transmitter and receiver are aligned.
Receiver activates but does not transmit signal to operator	Faulty connection between receiver and operator control input	Verify all wires and terminal connections.
Output relay chatters constantly between open and close	Interference	<ol style="list-style-type: none"> <li>1. Wire EGND to Rx mounting hole</li> <li>2. Check for nearby sources of interference (Ex. Other photoeyes or motors)</li> <li>3. Lower sensitivity potentiometer</li> </ol>

## Warranty

EMX Industries, Inc. products have a warranty against defects in materials and workmanship for a period of two years from date of sale to our customer.